

Uninterruptible Power System (60–600kVA)

User Manual



Preface

Usage

This manual introduces the main features, performance, working principle of the new generation modular intelligent UPS and provides users with information on installation, use, operation and maintenance.

Users

Technical support engineer

Maintenance engineer

Note

Our company is providing a full range of technical support and service. Customers can contact our local office or customer service center for help. The manual will update irregularly, due to the product upgrading or other reasons. Unless otherwise agreed, the manual is only used as guide for users and any statements or information contained in this manual make no warranty expressed or implied.

Our company reserves all rights. Contents are subject to change without prior notice.

Contents

1. Safety Precautions	1
1.1. Safety Message Definition	1
1.2. Warning Label	1
1.3. Safety Instruction	1
1.4. Move & Installation	2
1.5. Debug & Operate	2
1.6. Maintenance & Replacement	2
1.7. Battery Safety	3
1.8. Disposal	3
1.9. Symbol Description	3
2. Overview	4
2.1. Product Description	4
2.2. System Composition	4
2.3. UPS Power Module	4
2.4. Operating Mode	5
2.5. Normal Mode	5
2.5.1. Battery Mode	5
2.5.2. Combined Power Supply Mode	6
2.5.3. Bypass Mode	6
2.5.4. Maintenance Bypass Mode	7
2.5.5. ECO Mode	8
2.5.6. Auto-restart Mode	8
2.5.7. Frequency Converter Mode	8
2.6. UPS Structure	8
2.6.1. UPS Configuration	8
2.6.2. UPS Structure	9
3. Installation	11
3.1. Location	11
3.1.1. Installation Environment	11
3.1.2. Site Selection	11
3.1.3. Weight and Dimension	11
3.2. Unloading and Unpacking	13
3.2.1. Moving and Unpacking of the Cabinet	13
3.3. Positioning	15
3.3.1. Positioning Cabinet	15
3.3.2. Use Seismic Fixed Device to Fix Cabinet	16
3.4. Battery	18
3.5. Cable Entry	18

3.6. Power Cables.....	20
3.6.1. Specifications	20
3.6.2. Specifications for Power Cables Terminal	21
3.6.3. External Circuit Breaker.....	21
3.6.4. Connecting Power Cables	21
3.7. Control and Communication Cables	23
3.7.1. Dry Contact Interface.....	24
3.7.2. Communication Interface	29
4. Control and Display Panel.....	30
4.1. Cabinet Display panel	30
4.1.1. Audible Alarm Indication	30
4.1.2. Control Operation Key	30
4.1.3. LCD Touch Screen	30
4.2. Main Menu.....	32
4.2.1. Cabinet	32
4.2.2. Module	34
4.2.3. Log	37
4.2.4. Setting	42
4.2.5. Operate	45
4.2.6. Scope	46
5. Operation	48
5.1. UPS Start-up	48
5.1.1. Start in Normal Mode.....	48
5.1.2. Start from Battery.....	49
5.2. Operation Modes Switching.....	49
5.2.1. Switching to Battery Mode from Normal Mode	49
5.2.2. Switching to Bypass Mode from Normal Mode.....	49
5.2.3. Switching to Normal Mode from Bypass Mode.....	50
5.2.4. Switching to Maintenance Bypass Mode from Normal Mode	50
5.2.5. Switching to Normal Mode from Maintenance Bypass Mode	50
5.3. Battery Test	51
5.4. EPO	52
5.5. Installation of Parallel System.....	53
6. Maintenance	55
6.1. Contents of This Chapter.....	55
6.2. System Maintenance Instruction	55
6.2.1. Precautions	55
6.2.2. Instruction for Maintaining Power module	55
6.2.3. Monitoring Bypass Module for Cabinet.....	56

6.2.4. Battery Maintenance	56
7. Product Specification	58
7.1. Content	58
7.2. Applicable Standards.....	58
7.3. Environmental Characteristics	58
7.4. Mechanical Characteristic	59
7.5. Electrical Characteristics.....	59
7.5.1. Electrical Characteristics (Input Rectifier).....	59
7.5.2. Electrical Characteristics (Intermediate DC Link).....	60
7.5.3. Electrical Characteristics (Inverter Output).....	60
7.5.4. Electrical Characteristics (Bypass Utility Input).....	61
7.6. Efficiency	62
7.7. Display and Interface	62

1. Safety Precautions

Before handling, installation, operation, maintenance, please read the instruction manual carefully and follow all safety precautions in the manual. If neglected, it may cause personal injury or equipment damage, or even death.

The Company will not be liable for injuries and equipment damage caused by your company or your company's customers not following the safety precautions in the instruction manual.

1.1. Safety Message Definition

Danger: Serious human injury or even death may be caused, if this requirement is ignored.



Warning: Human injury or equipment damage may be caused, if this requirement is ignored.

Attention: Equipment damage, loss of data or poor performance may be caused, if this requirement is ignored.





Commissioning Engineer: The engineer who installs or operates the equipment should be well trained in electricity and safety, and familiar with the operation, debug, and maintenance of the equipment.

1.2. Warning Label



The warning label indicates the possibility of human injury or equipment damage, and advised the proper step to avoid the danger. In this manual, there are three types of warning labels as below.

Labels	Description
 Danger	Serious human injury or even death may be caused, if this requirement is ignored.
 Warning	Human injury or equipment damage may be caused, if this requirement is ignored.
 Attention	Equipment damage, loss of data or poor performance may be caused, if this requirement is ignored.



1.3. Safety Instruction

 Danger	<ul style="list-style-type: none"> ◇ Performed only by commissioning engineers. ◇ This UPS is designed for commercial and industrial applications only, and is not intended for any use in life-support devices or system.
 Warning	<ul style="list-style-type: none"> ◇ Read all the warning labels carefully before operation, follow the instructions.
	<ul style="list-style-type: none"> ◇ When UPS is running, don't touch the surface with this label, to avoid scald.
	<ul style="list-style-type: none"> ◇ ESD sensitive components inside the UPS, anti-ESD measure should be taken before handling.



1.4. Move & Installation

 Danger	<ul style="list-style-type: none"> ✧ Keep the equipment away from heat source or air outlets. ✧ Use dry powder extinguisher only, liquid extinguisher can result in electric shock.
 Warning	<ul style="list-style-type: none"> ✧ Do not install the UPS on flammable materials and avoid close contact or adhesion of flammable materials by the UPS. ✧ Please connect the brake options (brake resistance, brake unit or feedback unit) according to the wiring diagram. ✧ Do not start the system if any damage or abnormal parts founded. ✧ Do not contact UPS with wet material, hands to avoid electric shock.
 Attention	<ul style="list-style-type: none"> ✧ Use proper facilities to handle and install the UPS. Shielding shoes, protective clothes and other protective facilities are necessary to avoid injury. ✧ During positioning, keep the UPS way from shock or vibration. ✧ Install the UPS in proper environment, more detail in section 3.3. ✧ Avoid screws, cables, and other conductive objects from falling into the UPS.

1.5. Debug & Operate

 Danger	<ul style="list-style-type: none"> ✧ Make sure the grounding cable is well connected before connecting the power cables, the grounding cable and neutral cable must be in accordance with the local and national codes practice. ✧ Before moving or re-connecting the cables, make sure to cut off all the input power sources, and wait for at least 10 minutes for internal discharge. Use a multi-meter to measure the voltage on terminals and ensure the voltage is lower than 36V before operation.
 Attention	<ul style="list-style-type: none"> ✧ Do not disconnect and close the UPS input power frequently. ✧ The earth leakage current of load will be carried by RCCB or RCD. ✧ Initial check and inspection should be performed after long time storing of UPS.

1.6. Maintenance & Replacement

 Danger	<ul style="list-style-type: none"> ✧ All the equipment maintenance and servicing procedures involving internal access need special tools and should be carried out only by trained personnel. The components that can only be accessed by opening the protective cover with tools cannot be maintained by user. ✧ This UPS full complies with “IEC62040-1-1-General and safety requirements for use in operator access area UPS”. Dangerous voltages are present within the battery box. However, the risk of contact with these high voltages is minimized for non-service personnel. Since the component with dangerous voltage can only be touched by opening the protective cover with a tool, the possibility of touching high voltage component is minimized. No risk exists to any personnel when operating the equipment in the normal manner, following the recommended operating procedures in this manual.
 Attention	<ul style="list-style-type: none"> ✧ Please tighten the screws with appropriate torque. ✧ When maintaining and replacing components, UPS and components must be avoided from contacting or accompanying flammable materials. ✧ In the process of maintenance and component replacement, anti-static measures must be taken for UPS and internal devices.

1.7. Battery Safety

	<ul style="list-style-type: none"> ✧ All the battery maintenance and servicing procedures involving internal access need special tools or keys and should be carried out only by trained personnel. ✧ WHEN CONNECTED TOGETHER, THE BATTERY TERMINAL VOLTAGE WILL EXCEED 400Vdc AND IS POTENTIALLY LEATHAL. ✧ Battery manufacturers supply details of the necessary precautions to be observed when working on, or in the vicinity of, a large bank of battery cells. These precautions should be followed implicitly at all times. Particular attention should be paid to the recommendations concerning local environmental conditions and the provision of protective clothing, first aid and fire-fighting facilities. ✧ The life of the battery shortens with the increase of ambient temperature. Replacing the battery regularly ensures that the UPS is working properly and guarantees sufficient backup time. ✧ Replace the batteries only with the same type and the same number, or it may cause explosion or poor performance. ✧ When connecting the battery, the voltage at the battery end will exceed the dangerous voltage of 400Vdc, in order to avoid electric shock and injury, please observe the following warnings when replacing the battery: <ul style="list-style-type: none"> ● Eye protection should be worn to prevent injury from electrical arcs. ● Remove the finger ring, watch, necklace, bracelet, any other metal jewelry. ● Use insulated tools. ● Wear protective overalls and rubber gloves. ● Do not place metal tools or similar metal parts on the battery. ● Disconnect the load before removing the battery connection terminal. ● Please do not expose the battery to fire, causing an explosion on one side, endangering personal safety. ● Please do not short-circuit the positive and negative poles of the battery, which will cause electric shock or fire. ● If electrolyte comes into contact with the skin, the affected area should be washed immediately with water.
---	---

1.8. Disposal

	<ul style="list-style-type: none"> ✧ The components in the UPS contain heavy metals, and the UPS must be treated as industrial waste after disposal.
---	---

1.9. Symbol Description

Symbol	Description
	Indicates a supplement or emphasis on the main text.

2. Overview

2.1. Product Description

This Modular UPS is an online double-conversion UPS that uses digital signal processing (DSP) technology. Provide a stable and uninterrupted power supply for the important load. It can eliminate "power pollution" such as power surge, instantaneous high voltage, low voltage, wire noise and frequency offset on the utility, and provide customers with high-efficiency, high-power density power supply guarantee.

2.2. System Composition

The modular UPS is configured with the following parts: main input, static bypass, maintenance bypass and external battery, the system structure is shown in Figure 2-1:

The system connects multiple power modules in parallel, mainly including rectifier (REC), inverter (INV) and bidirectional DC_DC converter. The bypass static switch consists of a thyristor connected in reverse parallel, and the utility power can be supplied directly to the load through the bypass static switch. The maintenance bypass switch is a circuit breaker, and the maintenance bypass switch can be used to ensure the uninterrupted power supply to the load when repairing the UPS. When the utility power is cut off, the external battery pack will supply power to the load through the inverter.

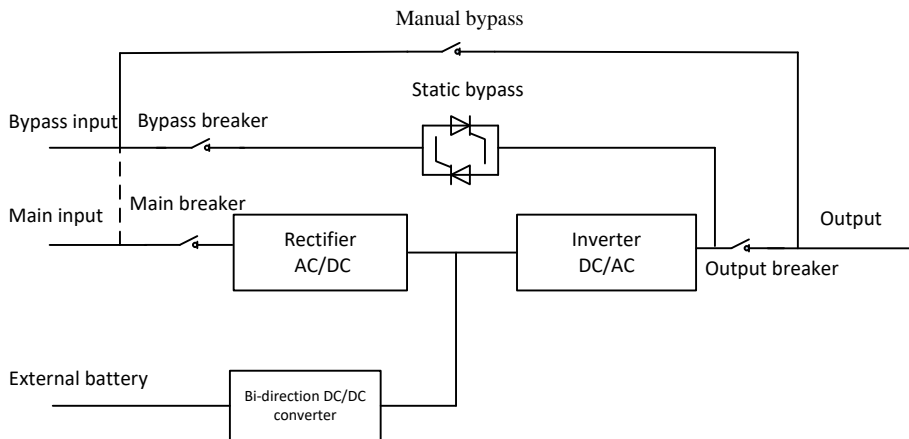

Figure 2-1 UPS system diagram

2.3. UPS Power Module

The power module conceptual diagram is shown as Figure 2-2. The power module contains a rectifier (AC/DC), an inverter (DC/AC), and a DC/DC converter (charge/discharge).

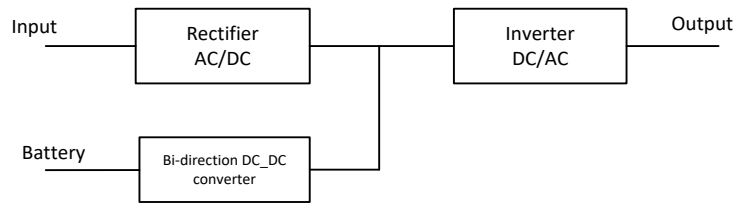

Figure 2-2 Power module diagram

2.4. Operating Mode

UPS system adopts online double-conversion design, according to different working conditions, can work in different working modes, including normal mode, battery mode, bypass mode, maintenance bypass mode, ECO mode, auto-restart mode and frequency converter mode.

2.5. Normal Mode

In normal mode, UPS change AC input into DC voltage (AC/DC) through the rectifier, DC voltage boost to bus (BUS) voltage, when the system is connected to the external battery, part of the battery is charged through the bidirectional DC_DC converter, the other part is changed to AC output (DC/AC) through the inverter, to provide high-quality AC power for the load. The normal mode working principle is shown in Figure 2-3:

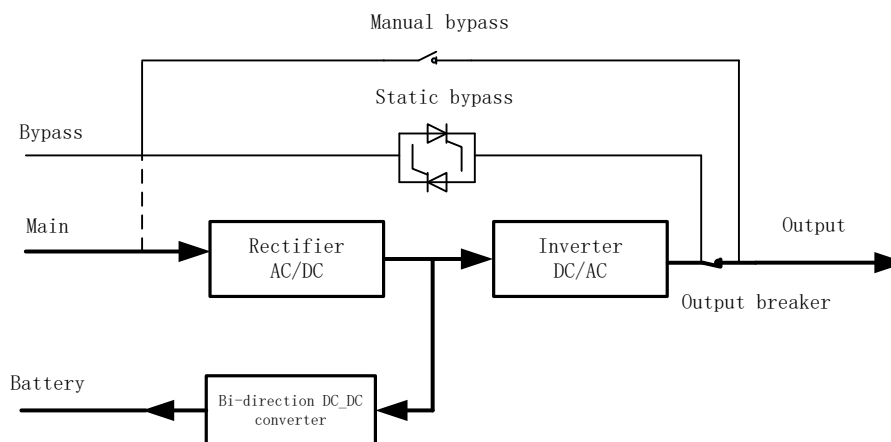

Figure 2-3 UPS conceptual diagram in normal mode

Note

The dark lines indicate the route involved in this mode of operation, and the arrows indicate the direction of energy flow, the same below.

2.5.1. Battery Mode

The operating mode in which the battery supplies AC power to the load through the inverter is called “battery mode”. There is no interruption to the critical load upon AC main input power failure; UPS will automatically switch to “battery mode”. After the utility is restored, the UPS

returns to “normal mode” without interruption. The working principle of the “battery mode” is as follows:

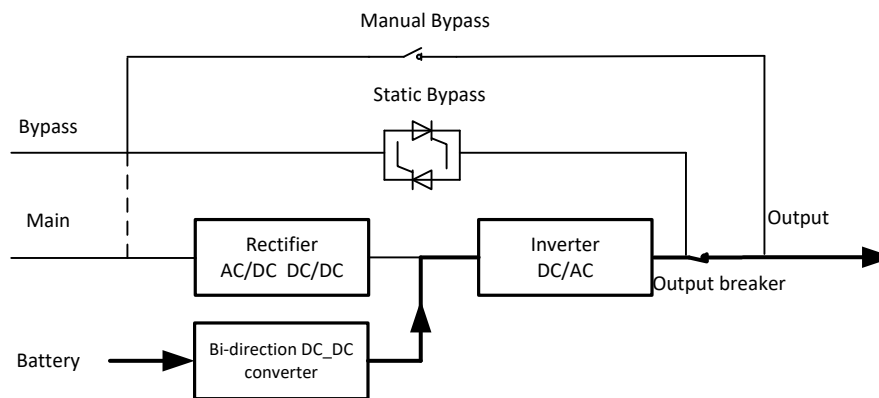

Figure 2-4 UPS conceptual diagram in battery mode

Note

With the function of Battery cold start, the UPS may start without utility (The battery has been charged). Therefore, the battery power supply can be used independently to expand the usage range of the system.

2.5.2. Combined Power Supply Mode

The mode in which the battery and the utility supply AC power to the load through the inverter is called combined power supply mode. When the utility voltage is lower than the load power supply voltage, the UPS automatically switches to the combined power supply mode, and the battery supplies extra power to ensure that the load power is not interrupted, extending the battery discharge time. As shown in Figure 2-5:

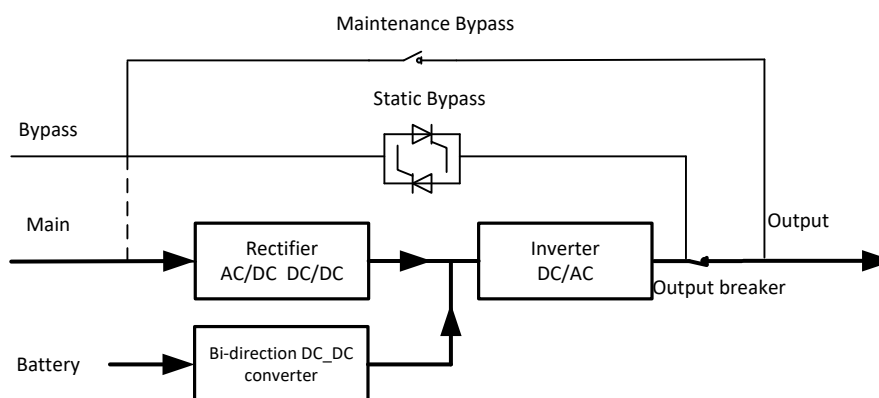

Figure 2-5 UPS conceptual diagram in combined power supply mode

2.5.3. Bypass Mode

After the system is powered on, if the inverter is not started or manually turned off, the load will be supplied by bypass; In normal mode, if the UPS monitoring unit detects that the power module over temperature, overload, or other failures may cause the inverter to shut down, the UPS automatically switches to bypass mode and the utility supply power directly to the load through

bypass static switch. In bypass mode, load power supply quality is not protected by the UPS and may be affected by power failure, abnormal voltage waveform or frequency. As shown in Figure 2-6:

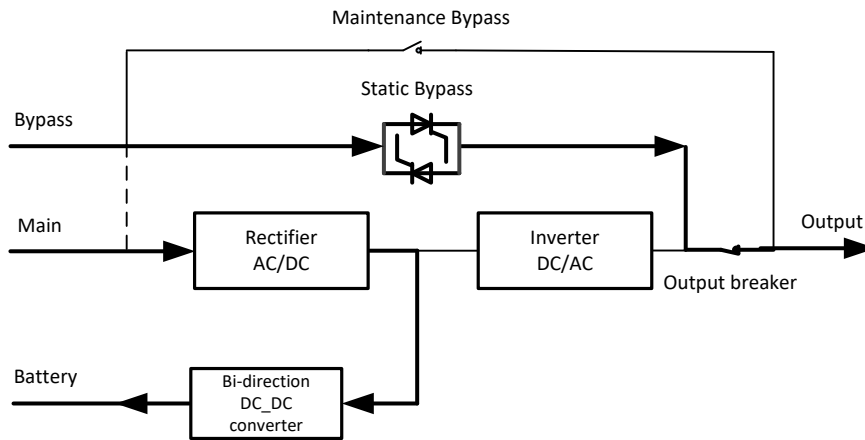

Figure 2-6 UPS conceptual diagram in bypass mode

2.5.4. Maintenance Bypass Mode

When the UPS system and batteries are repaired, you should transfer to bypass first. Then manually close the maintenance bypass breaker, and then open the input, output breaker, open the bypass breaker, and turn off the external battery circuit breaker in the end. The load is directly supplied by the utility through the maintenance bypass, so as to realize the maintenance of the system without power failure to the load. As shown in Figure 2-7:

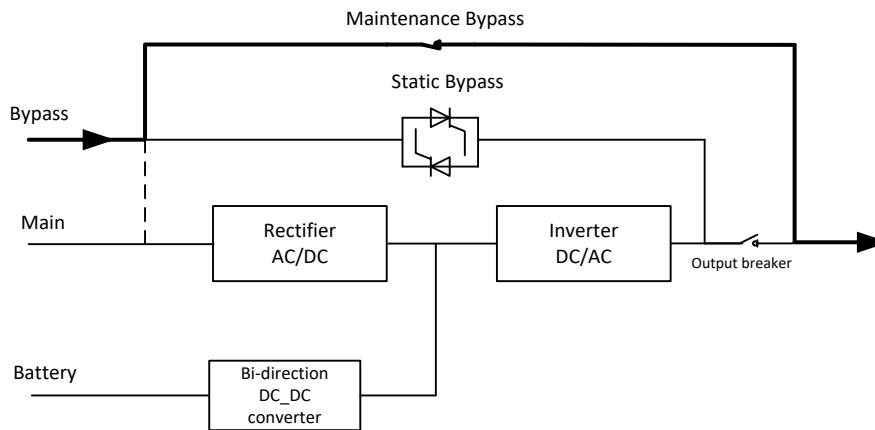

Figure 2-7 UPS conceptual diagram in maintenance mode



Danger

During Maintenance mode, hazardous voltages are present on the terminal of input, output and neutral, even with all the power, bypass module and LCD turned off.

2.5.5. ECO Mode

ECO mode is an UPS energy-saving mode which can be set through the LCD or background software. In ECO mode, when the bypass input voltage is within the ECO range, the load is powered by utility through bypass static switch, the rectifier and inverter are standby. When the bypass input voltage exceeds the ECO voltage range, the load will be switched from the bypass power supply to the inverter power supply, and the UPS will work in normal mode. In ECO mode, the system can achieve higher efficiency. As shown in Figure 2-8:

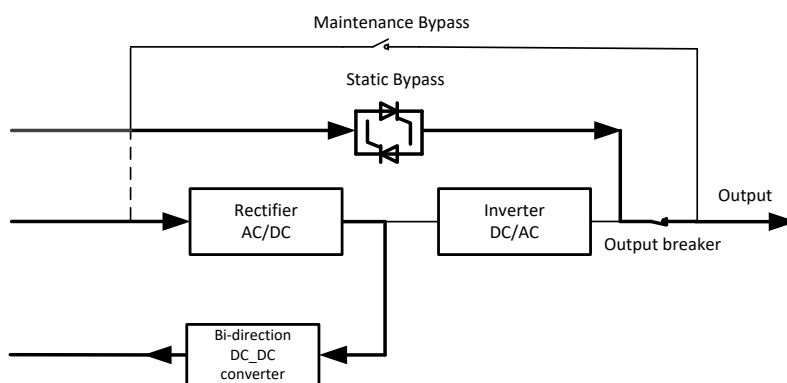

Figure 2-8 UPS conceptual diagram in ECO mode

2.5.6. Auto-restart Mode

The UPS supports Auto-restart function, after a long time of AC utility failure, the inverter shuts down when the battery reaches the End of Discharge Voltage (EOD). The UPS can be set the function of to “System Auto-Start Mode after EOD” to restart the UPS after the utility recover. This function can be set by trained and qualified professionals.

2.5.7. Frequency Converter Mode

By setting the UPS to Frequency Converter mode, the UPS could provide a stable output frequency (50 or 60Hz). Input frequency range is 40Hz–70Hz. In this mode, bypass is not available; the battery is optional based on whether it is required to operate in battery mode.

2.6. UPS Structure

2.6.1. UPS Configuration

The UPS configuration is provided in Table 2-1.

Table 2-1 UPS configuration

Item	Component	Quantity (pcs)	Remarks
600kVA Cabinet	Switching distribution unit	4	Standard configuration
	Monitoring & Bypass module	1	Standard configuration
60kVA Power module	Power module	1–10	/

2.6.2. UPS Structure

The UPS structure (front view) is shown in Figure 2-9. The back view is shown in Figure 2-10:

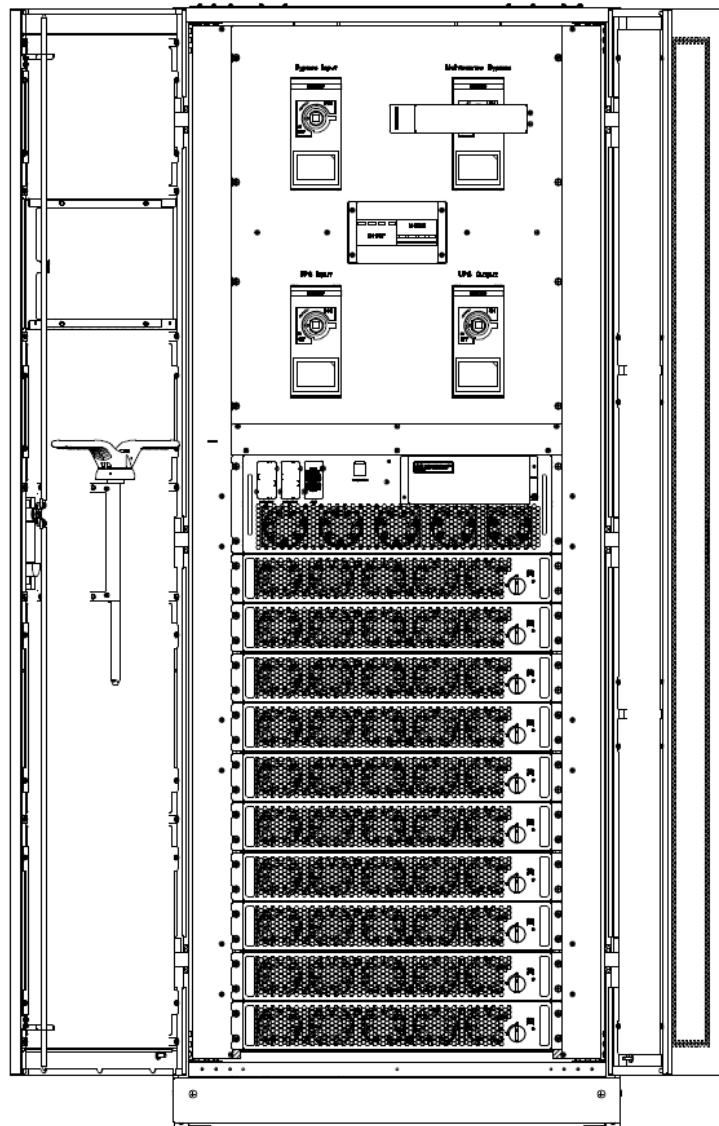

Figure 2-9 UPS cabinet front view

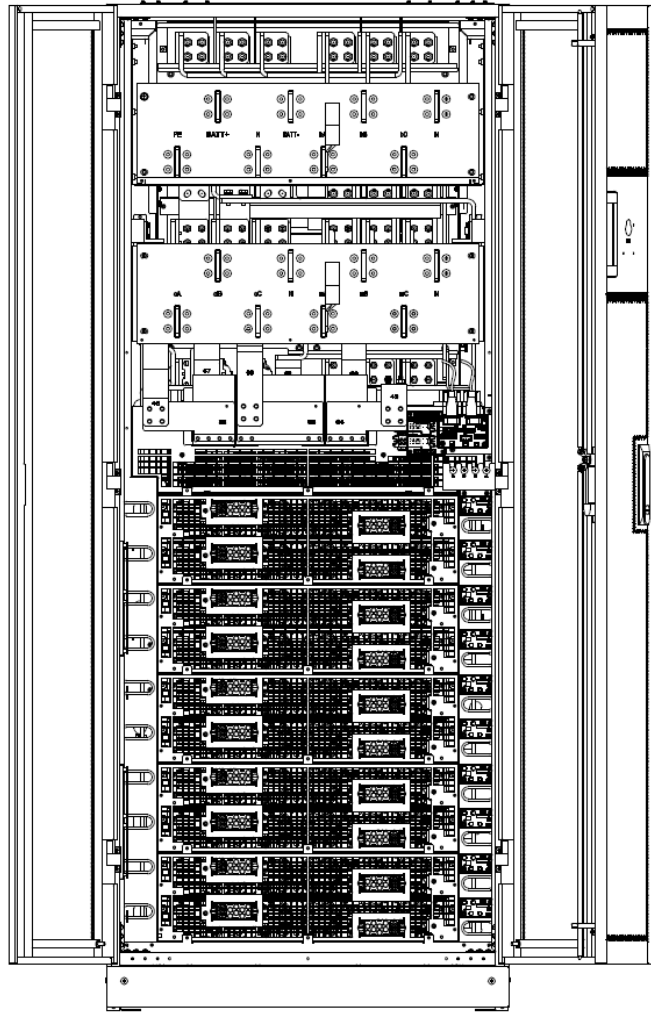

Figure 2-10 UPS cabinet back view

3. Installation

3.1. Location

3.1.1. Installation Environment

- The UPS is intended for indoor installation and uses forced convection cooling by internal fans. Please make sure there is enough space for the UPS ventilation and cooling.
- Keep the UPS far away from water, heat and inflammable and explosive, corrosive material. Avoid installing the UPS in the environment with direct sunlight, dust, volatile gases, corrosive material and high salinity.
- Avoid installing the UPS in the environment with conductive dirt.
- The operating environment temperature for battery is $22\pm 2^{\circ}\text{C}$. Operating above 30°C will reduce the battery life, and operation below 20°C will reduce the battery capacity.
- The battery will generate a little amount of hydrogen and oxygen at the end of charging; ensure the fresh air volume of the battery installation environment must meet EN50272-2001 requirements.
- If external batteries are to be used, the battery circuit breakers (or fuses) must be mounted as close as possible to the batteries, and the connecting cables should be as short as possible.

3.1.2. Site Selection

- Ensure the ground can bear the weight of the UPS cabinet, batteries and battery rack.
- No vibration and less than 5 degree inclination horizontally.
- If don't have to install UPS right away, the equipment should be stored in a room so as to protect it against excessive humidity and heat sources. The battery needs to be stored in dry and cool place with good ventilation. The most suitable storage temperature is 20°C to 25°C . Battery storage time is generally not more than 3 months, more than this time need to recharge.

3.1.3. Weight and Dimension

Ensure that the power distribution room has sufficient space for the UPS system. The dimensions of the UPS cabinet are shown in Figure 3-1:



Attention

Ensure there is at least 0.8m before the front of the cabinet so as to easily replace the power module with the front door fully open and at least 0.8m behind for ventilation and cooling, as shown in Figure 3-2:

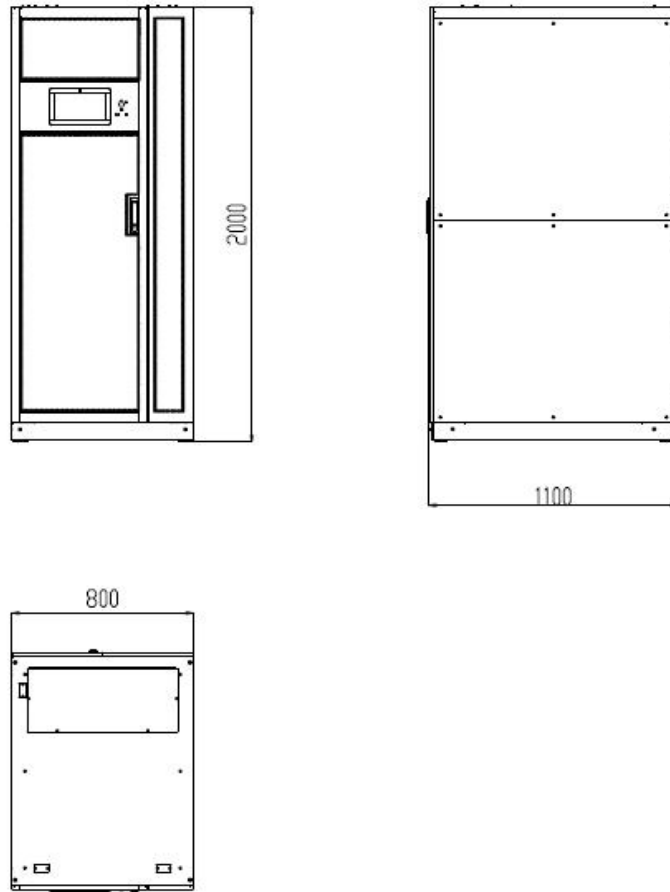

Figure 3-1 Dimensions of cabinet (unit: mm)

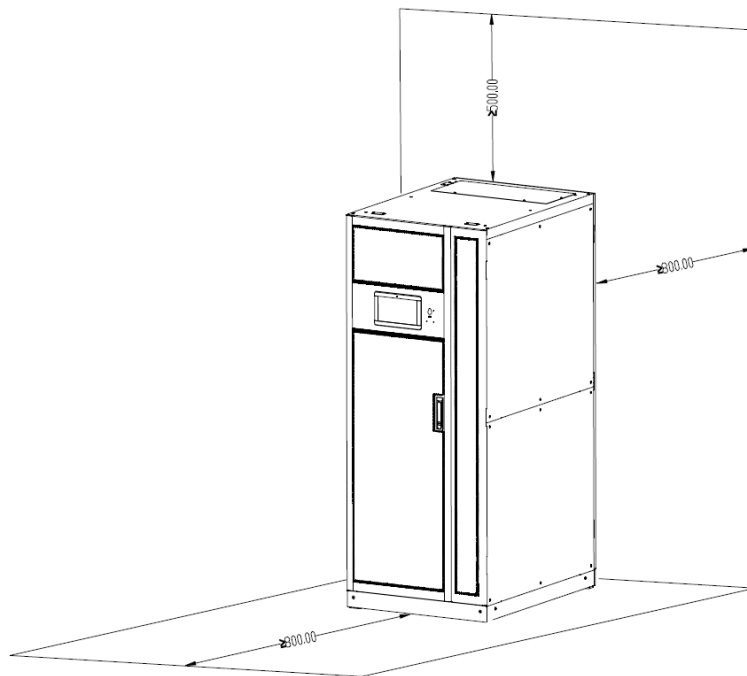

Figure 3-2 Reserved cabinet space (unit: mm)

Ensure that the floor or installation platform can bear the weight of the UPS cabinet, batteries, and battery racks. The weight of batteries and battery racks depends on the site requirements. The

weight for the UPS cabinet is listed in Table 3-1.

Table 3-1 Weight of the UPS

Item	Weight
600kVA cabinet (Not include bypass and power module)	353kg
600kVA Monitoring & Bypass module	52kg
60kVA Power module	36kg

3.2. Unloading and Unpacking

3.2.1. Moving and Unpacking of the Cabinet

The steps to move and unpack the cabinet are as follows:

Step 1: Check if any damages to the packing. (If any, contact to the carrier).

Step 2: Transport the equipment to the designated site by forklift, as shown in Figure 3-3:



Figure 3-3 Transport to the designated site

Step 3: Remove the top cover, tear off the Velcro, and remove the carton fence as shown in Figure 3-4:

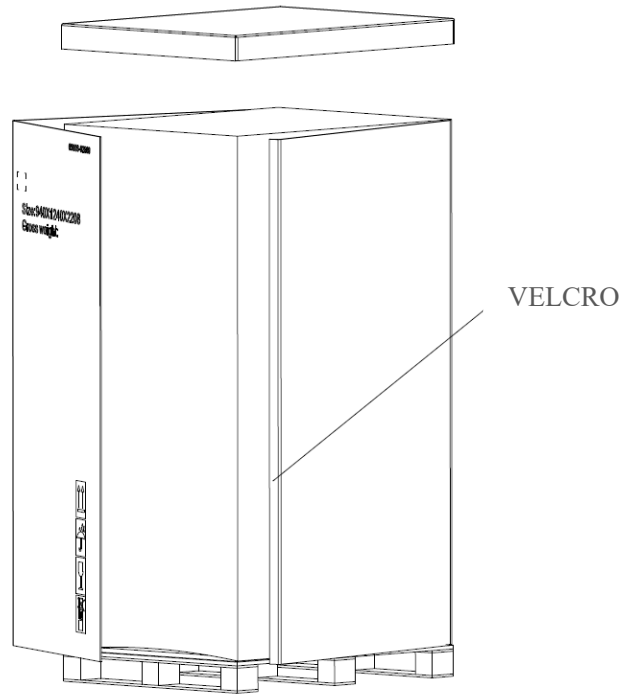

Figure 3-4 Disassemble the box

Step 4: Remove the protective foam around the cabinet as shown in Figure 3-5:

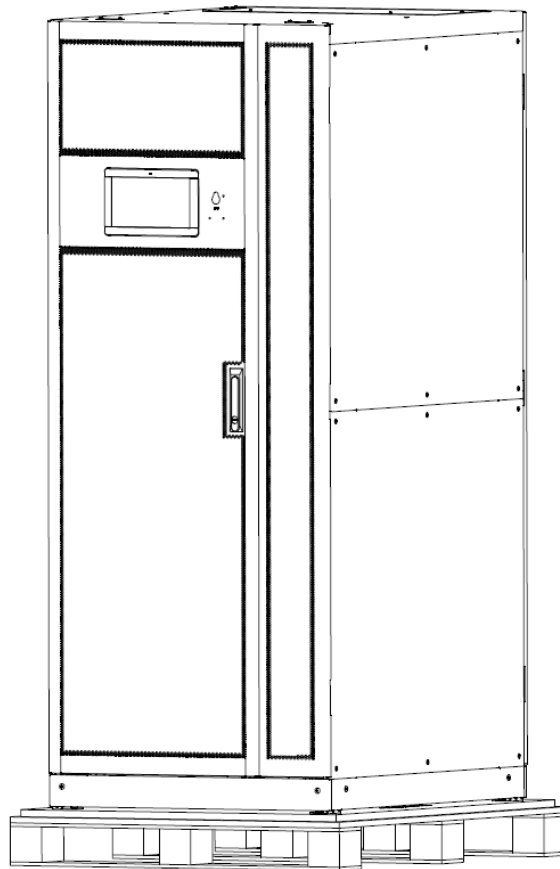

Figure 3-5 Remove the protective foam

Step 5: Check the UPS

1. Visually examine if there are damages to UPS during transportation. If any, contact to the carrier.
2. Check the delivery packing list to see if the accessories are complete and correct. If you find that the attachment is missing or the model does not match, you should timely make on-site records and contact our local office.

Step 6: After confirm the equipment in good condition, dismantle the bolt that connects the cabinet and wooden pallet after disassembly.

Step 7: Move the cabinet to the installation position.

**Attention**

Be careful while removing to avoid scratching the equipment.

The waste materials of unpacking should be disposed as the demand for environment protection.

3.3. Positioning

3.3.1. Positioning Cabinet

The weight of the UPS cabinet is supported by its four wheels at the bottom. The support method is generally used to support the cabinet for a long time after it is fixed in position. As shown in Figure 3-6:

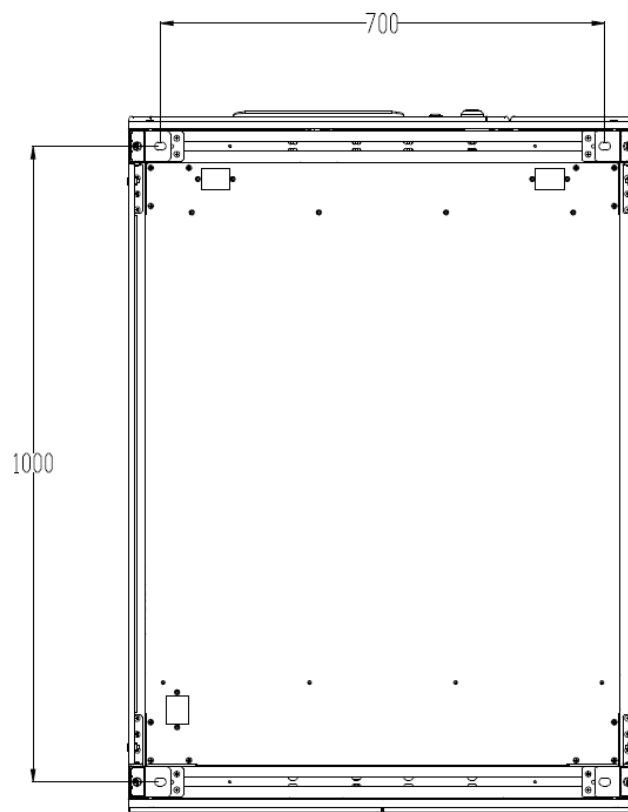

Figure 3-6 Supporting structure (bottom view)

The steps to position the cabinet is as follows:

- 1) Ensure the supporting structure is in good condition and the mounting floor is smooth and strong.
- 2) Push the cabinet to the installation point by forklift.
- 3) Fixed on the ground or channel steel through the bottom hole of the cabinet.
- 4) Ensure the four anchor bolts are in the same height and the cabinet is fixed and immovable.
- 5) Positioning done.



Attention

Auxiliary equipment is needed when the mounting floor is not solid enough to support the cabinet, which helps distribute the weight over a larger area. For instance, cover the floor with iron plate or increase the supporting area of the anchor bolts.

3.3.2. Use Seismic Fixed Device to Fix Cabinet

The Seismic fixed device is optional part. The device is delivered after factory installation. The following uses a 10-module cabinet as an example. As shown in Figure 3-7:

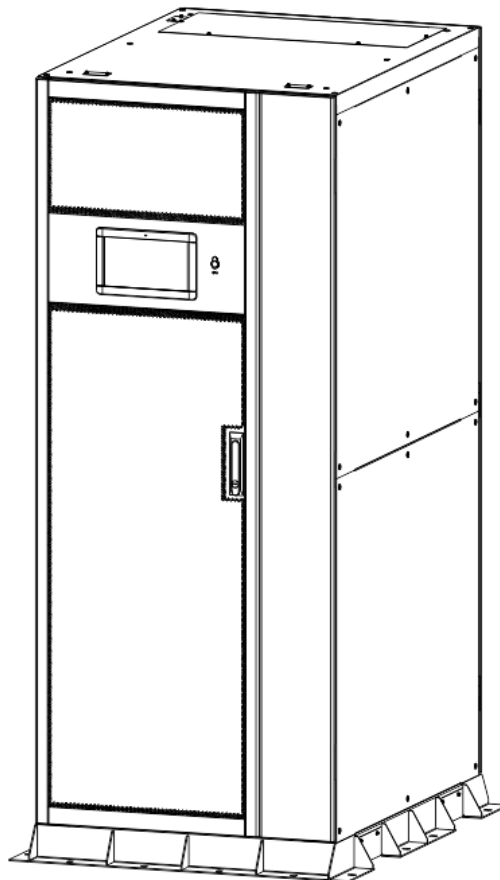

Figure 3-7 Cabinet with seismic fixed device

Ground Installation

- 1) Ensure that the installation ground is smooth.
- 2) Determine the installation position of the cabinet, and draw installation holes on the installation surface according to the seismic fixed device and equipment size diagram. The seismic fixed device and equipment dimension diagram is shown in Figure 3-8:

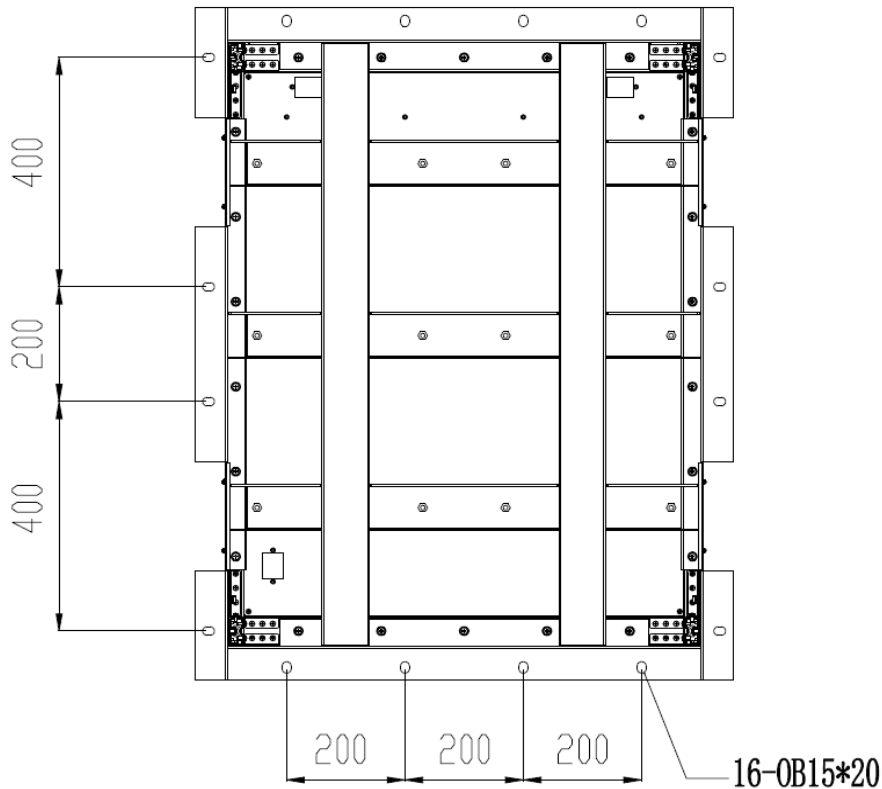

Figure 3-8 Dimensional drawings of seismic fixed device

- 3) Drill holes on the installation holes of the expansion bolts on the left and right sides of the cabinet using an impact drill, and then tap the expansion pipes of 16nos M14 expansion bolts into the installation holes.
- 4) Push the cabinet to the installation ground and fix the cabinet to the installation ground using the screws of the M14 expansion bolts.



Attention

The expansion pipe of the expansion bolt should be tapped to be flush with the installation surface, and the expansion pipe should not be higher than the installation surface.

Channel steel installation

- 1) According to the seismic components and equipment dimension diagram, install the channel steel, it is recommended that the width of the channel steel should be more than 50mm, and the channel steel surface should be flush with the ground, and should not be tilted. Determine the bolt mounting holes on the channel steel.
- 2) Use an impact drill to drill holes on the installation hole of the channel steel, with a hole diameter of M14.
- 3) Use a top crane to transport the cabinet to the installation location.
- 4) Using 16nos M14 fix the cabinet to the installation hole of the channel steel with 45 hexagonal bolts and tighten the bolts with nuts.

3.4. Battery

Three terminals (positive, neutral, negative) are drawn from the battery unit and connected to UPS system. The neutral line is drawn from the middle of the batteries in series. See Figure 3-9.

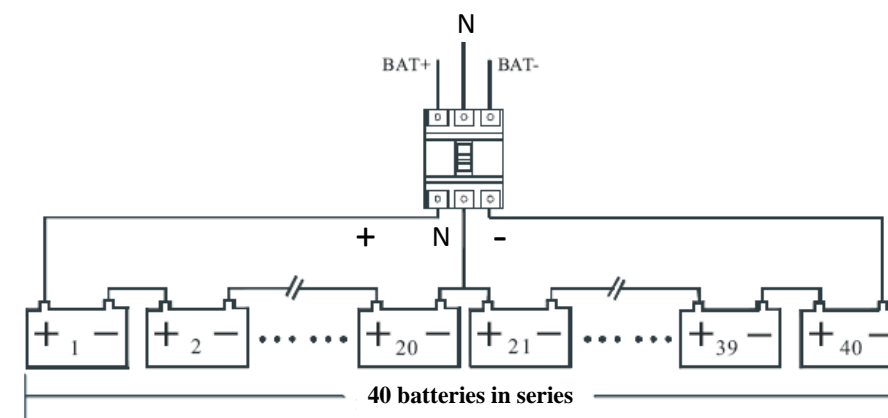

Figure 3-9 Battery string wiring diagram



Danger

The battery terminal has hazardous voltage, please follow the safety instructions to avoid electric shock hazard. Ensure the positive, negative, neutral electrode is correctly connected from the battery unit terminals to the external switch of battery strings and from the external switch to the UPS system.

3.5. Cable Entry

The cabinet support enters from the top side. The cable entry is shown in Figure 3-10. If you need to enter from the bottom side, a bottom-entry cabinet is optional. The bottom-entry mode and size of the system are shown in Figure 3-11.

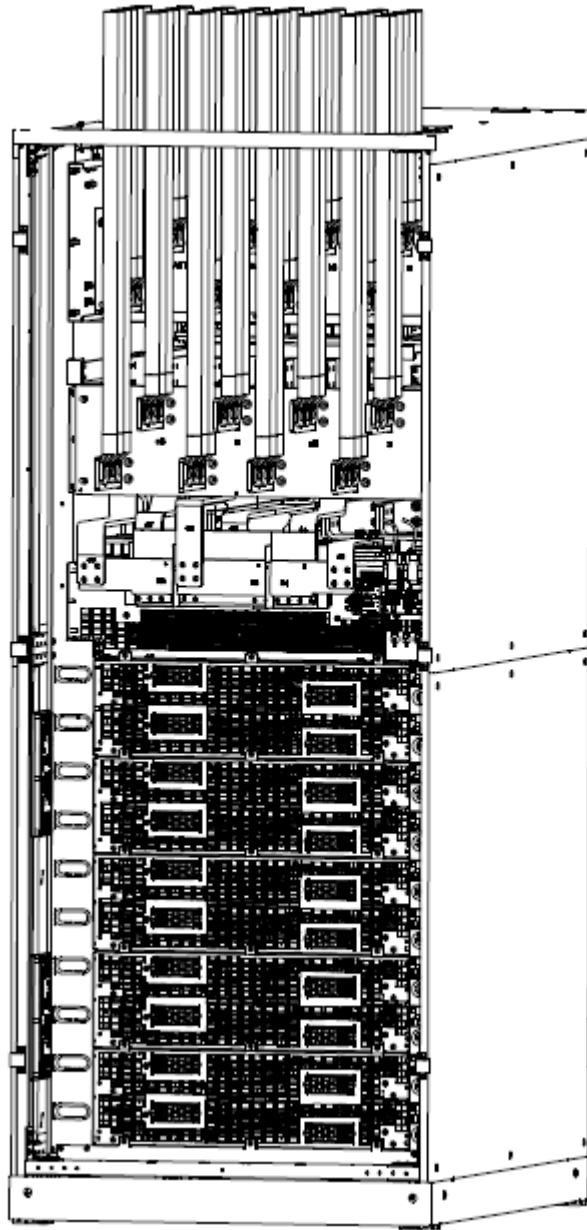

Figure 3-10 Diagram of top cable entry

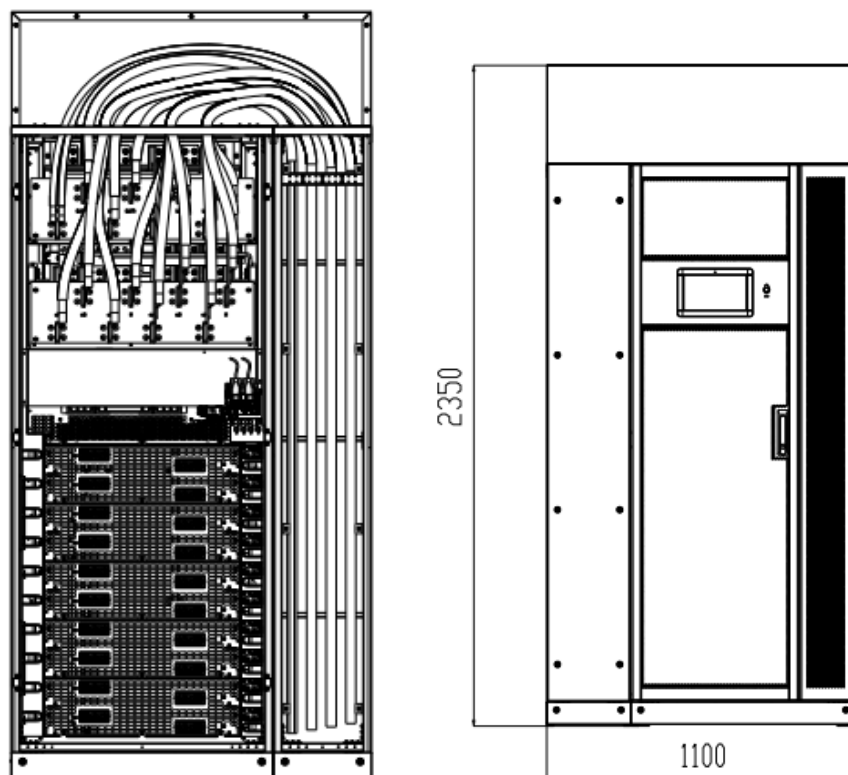

Figure 3-11 Diagram of bottom cable entry

3.6. Power Cables

3.6.1. Specifications

The selection of UPS system power cable should meet the 3B in IEC60950-1. Select suitable cable in combination with practical engineering applications, maximum UPS operating current provided in Table 3-2.

Table 3-2 Power cable maximum working current

Contents		10-solt cabinet
Main Input	Main Input Current(A)	1200
Main Output	Main output Current(A)	910
Bypass Input	Bypass Input Current(A)	910
Battery input	Battery Input Current(A)	1300

 **Note**

The recommended cable for power cables in Table 3-2 are only for situations described below:

- Ambient temperature: 30°C.
- AC voltage loss less than 3%, DC voltage loss less than 1%, the length of the UPS AC power cable is no longer than 30 m and the length of the DC power cable is no longer than 40 m. After exceeding, the cable specification should be increased.
- When external conditions change, 90 °C copper conductor flexible cables need to be

verified by referring to IEC60364-5-52 and local relevant specifications. The current values in the table are for data with a rated line voltage of 380V. For a rated voltage of 400V, the current value needs to be multiplied by 0.95; for rated voltage of 415V, the current value needs to be multiplied by 0.92.

- The size of neutral lines should be 1.5–1.7 times the value listed above when the predominant load is non-linear.

3.6.2. Specifications for Power Cables Terminal

Specifications for power cables terminal are listed as Table 3-3.

Table 3-3 Requirements for power module terminal

Cabinet	Port	Connection	Bolt	Torque Moment
10-slot cabinet	Utility input	Cables crimped OT terminal	M16	96Nm
	Bypass Input	Cables crimped OT terminal	M16	96Nm
	Battery Input	Cables crimped OT terminal	M16	96Nm
	Output	Cables crimped OT terminal	M16	96Nm
	PE	Cables crimped OT terminal	M16	96Nm

3.6.3. External Circuit Breaker

The UPS system needs to be configured with external distribution circuit breakers, including main input circuit breakers, bypass input circuit breakers (configured for dual input), output circuit breakers, maintenance bypass circuit breakers, and battery output circuit breakers. The circuit breakers (CB) for the system are recommended in Table 3-4.

Table 3-4 Recommended CB

Installed position	10-slot cabinet
Main input front	1250A/3P
Bypass input front	1250A/3P
Output rear	1250A/3P
Maintenance Bypass	1250A/3P
Battery output front	1600A/3P



Attention

The CB with RCD (Residual Current Device) is not suggested for the system.

3.6.4. Connecting Power Cables

The steps of connecting power cables are as follows:

Step 1: Verify that all the input switches of the UPS are completely open, and the UPS internal power is all shut down. Attach necessary warning signs to these switches to prevent unauthorized operation.

Step 2: Open the front door of the cabinet (10-slot Cabinet opens the back door), remove the plastic cover. The input and output terminal, battery terminal and protective earth terminal are shown in Figure 3-12:

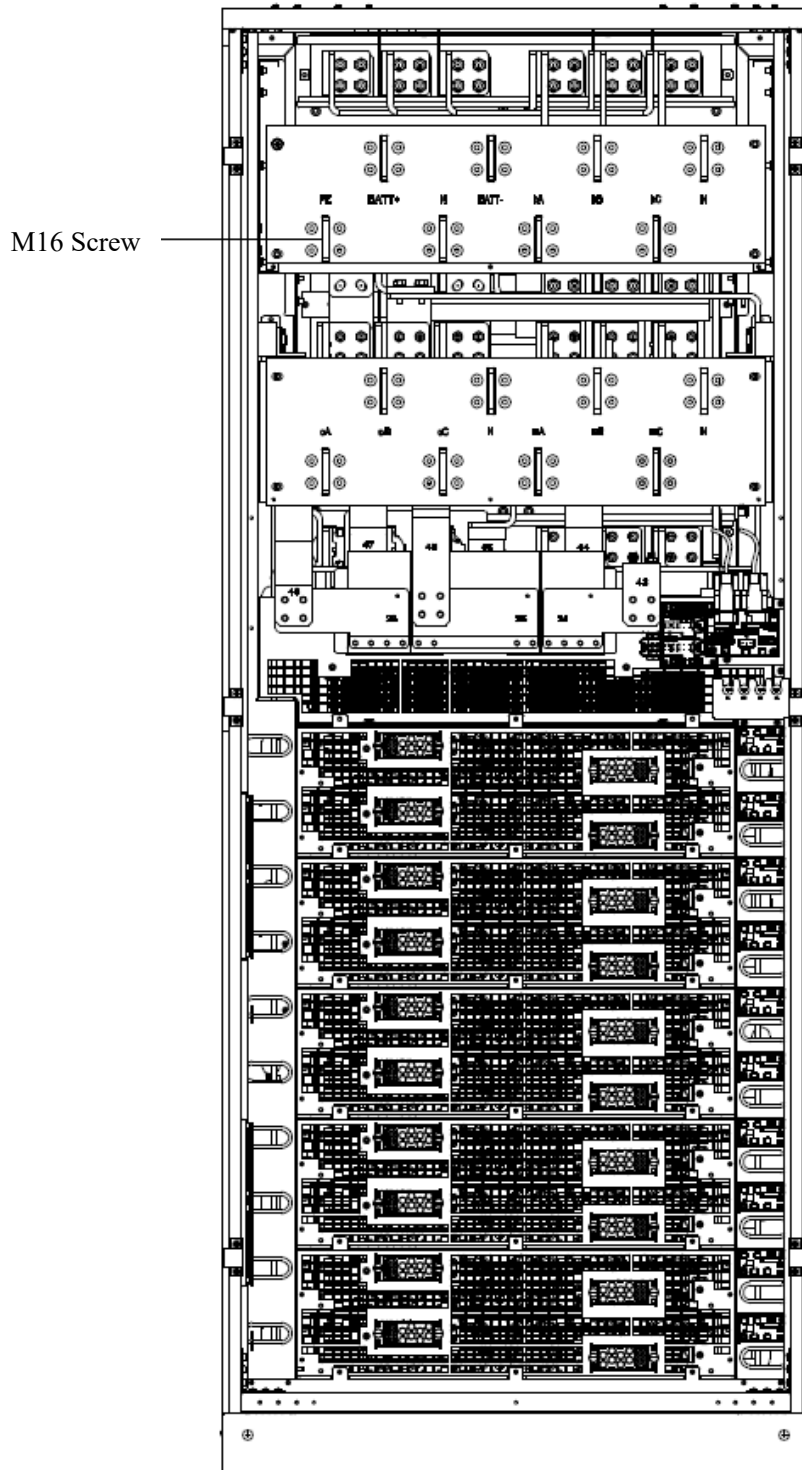

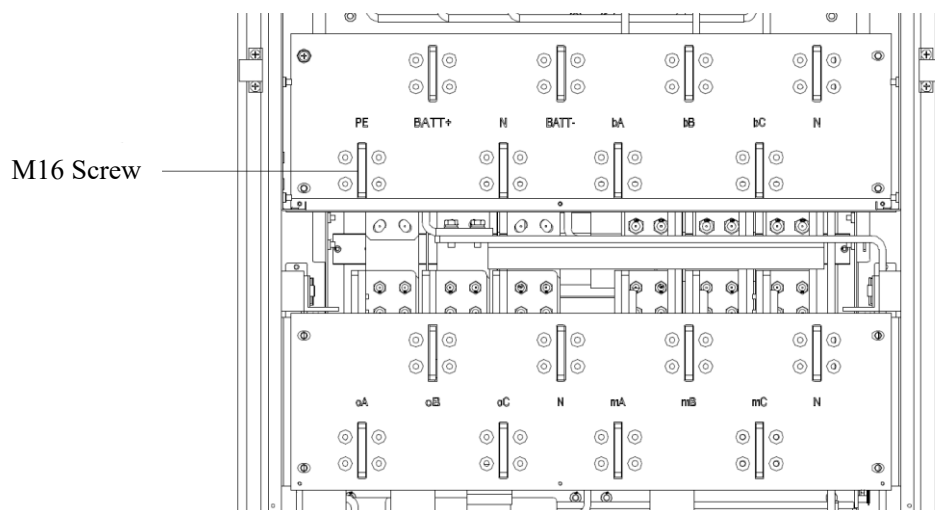

Figure 3-12 Connection terminals

Step 3: Connect the input ground wire to the input ground terminal. Note that the ground wire connection must comply with local and national regulations.

Step 4: Connect the AC main input cable to the input terminal (mA, mB, mC, N); Connect the AC bypass input cable to the bypass input terminal (bA, bB, bC, N); Connect the output cable to the output terminal (oA, oB, oC, N), as shown in Figure 3-10 or 3-11.

Step 5: Connect the battery cables to the Battery terminal (Batt+, N, Batt-).

Step 6: Check to make sure there is no mistake and re-install all the protective covers, complete the connection.



Warning

- When connecting power cables, follow the torque moment given in Table 3-3. To ensure the tightness of the wiring terminals and avoid safety risks.
- Before wiring the UPS, ensure that you know the position and status of the switch connecting the UPS input to the utility power distribution. Ensure that the breaker is off and attaches warning labels to prevent others from operating the switch.

3.7. Control and Communication Cables

The front panel of the bypass module provides dry contact interface (EPO, NPC, IP, OP) and communication interface (CAN, RS485, Intelligent card slot and USB Port), as shown in Figure 3-13.

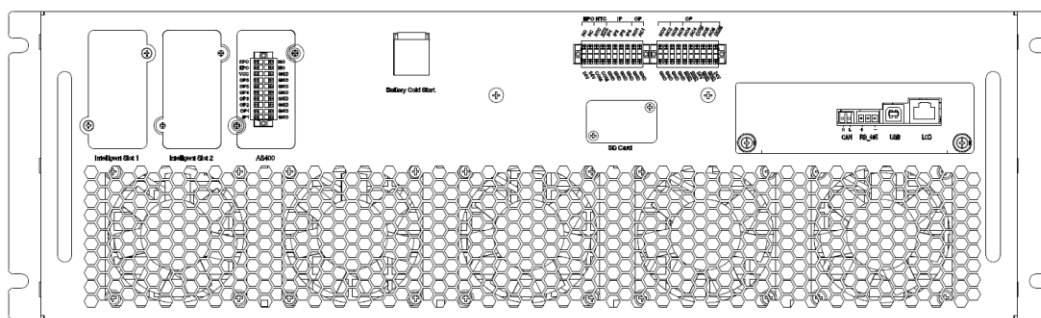

Figure 3-13 System communication interface

3.7.1. Dry Contact Interface

Dry contact interface includes EPO, NTC, IP, OP, as shown in Figure 3-14. The interface function can be set by software. The functions of the dry contacts are provided in Table 3-5:

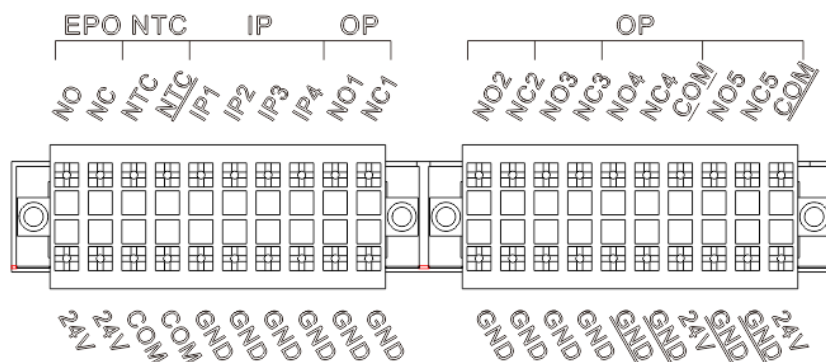

Figure 3-14 Dry contact interface

Table 3-5 Functions of the port

Port	Name	Function
NTC-NTC	TEMP_BAT	Detection of battery temperature
NTC-NTC	ENV_TEMP	Detection of environmental temperature
NTC-COM	TEMP_COM	Common terminal for temperature detection
EPO-NC	REMOTE_EPO_NC	Trigger EPO when disconnect with EPO-24V
EPO-24V	+24V_DRY	+24V
EPO-NO	REMOTE_EPO_NO	Trigger EPO when shorted with EPO-24V
IP-IP1	GEN_CONNECTED	Internal input dry contact, function is settable Default: interface for generator
IP-IP2	BCB Status	Internal input dry contact, function is settable Default: BCB Status (Alert no battery when BCB Status is invalid)
IP-IP3	BCB Online	Internal input dry contact, function is settable Default: BCB Online (Alert no battery when BCB Status is invalid)

IP-IP4	Silence	Internal input dry contact, function is settable Default: Mute the alarm
IP-GND	GND_DRY	Ground for +24V
OP-NO1	BCB Drive_NO	Internal output dry contact, (Normally open) function is settable Default: Battery CB trip signal (Valid under EOD or EPO)
OP-NC1	BCB Drive_NC	Internal output dry contact, (Normally close) function is settable Default: Battery CB trip signal (Valid under EOD or EPO)
OP-NO2	BAT_LOW_ALARM_NO	Internal output dry contact, (Normally open) function is settable Default: Battery low voltage alarming
OP-NC2	BAT_LOW_ALARM_NC	Internal output dry contact (Normally closed), function is settable Default: Battery low voltage alarming
OP-NO3	GENERAL_ALARM_NO	Internal output dry contact, (Normally open) function is settable Default: General alarming
OP-NC3	GENERAL_ALARM_NC	Internal output dry contact, (Normally closed) function is settable Default: General alarming
OP-NO4	UTILITY_FAIL_NO	Internal output dry contact, (Normally open) function is settable Default: Utility abnormal alarming
OP-NC4	UTILITY_FAIL_NC	Internal output dry contact, (Normally closed) function is settable Default: Utility abnormal alarming
OP-NO5	Overload_NO	Internal output dry contact, (Normally open) function is settable Default: Overload alarming
OP-NC5	Overload_NC	Internal output dry contact, (Normally close) function is settable Default: Overload alarming
OP-GND	GND	Internal output dry contact GND
OP-24V	OP4_24V	+24V
OP-GND	<u>GND</u>	OP-5 Internal output dry contact <u>GND</u>
OP-GND	<u>GND</u>	OP-4 Dry contact <u>GND</u>
OP-VCC	VCC	OP-5, optional connected to external power supply or internal 24V

OP-COM	COM	OP-5 COM port, optional external VCC and internal power supply 24V
OP-COM	COM	OP-4 COM port, optional external VCC and internal power supply 24V

 **Note**

The function of each port can be set by the monitor software.

The default functions of each port are described as follows.

Battery and Ambient Temperature Detection Dry Contact Interface

The input dry contact NTC can detect the ambient temperature of batteries and environment respectively, which can be used in environment monitoring and battery temperature compensation.

Interfaces diagram for NTC are shown in Figure 3-15 and the interfaces are described in Table 3-6:

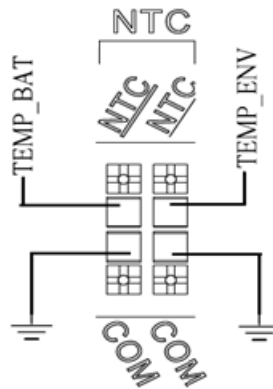

Figure 3-15 NTC for temperature detecting

Table 3-6 Description of NTC and NTC

Port	Name	Function
NTC- <u>NTC</u>	TEMP_BAT	Detection of battery temperature
NTC- <u>NTC</u>	TEMP_COM	Detection of ambient temperature
NTC-COM	ENV_TEMP	Temperature detection common port

 **Note**

Specified temperature sensor is required for temperature detection (R25=5Kohm, B25/50=3275), please confirm with the manufacturer, or contact the local maintenance engineers when placing an order.

Remote EPO Input Port

For normal operation, the EPO_NC needs to be shorted with +24V, disconnect the EPO_NC from +24V when the EPO needs to be triggered. The port diagram is shown in Figure 3-16 and port description is provided in Table 3-7.

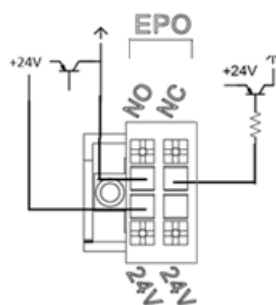

Figure 3-16 Diagram of input port for remote EPO

Table 3-7 Description of input port for remote EPO

Port	Name	Function
EPO-NC	REMOTE_EPO_NC	Trigger EPO when disconnect with J4-2
EPO-24V	24V_DRY	+24V
EPO-NO	REMOTE_EPO_NO	Trigger EPO when shorted with J4-3

When UPS system in normal operation, port EPO-NC to EPO-24V should be shorted circuit, and EPO-NO to EPO-24V should be open. If port EPO-NC to EPO-24V is opening or EPO-NO to EPO-24V is shorted circuit, the ups will trigger an emergency shutdown.

Generator Input Dry Contact

The default function of IP-IP1 is the interface for generator connecting. If IP1 is connected with IP1-GND, it indicates that the generator has been connected with the system. The interface diagram is shown in Figure 3-17, and interface description is provided in Table 3-8.

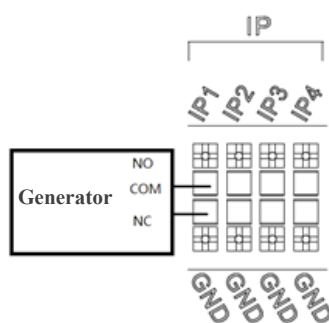

Figure 3-17 Diagram of status interface and connection of generator

Table 3-8 Description of status interface and connection of generator

Port	Name	Function
IP-IP1	GEN_CONNECTED	Connection status of generator
IP-GND	GND_DRY	Ground for +24V power

 **Note**

IP-IP2, IP-IP3, IP-IP4 for the connection diagram of the input dry contact, refer to IP-IP1.

Battery Warning Output Dry Contact Interface

The default function of OP-1 is the output dry contact interface, default as the battery CB trip signal (under EOD or EPO). An auxiliary dry contact signal will be activated via the isolation of a relay to trip the CB. The interface diagram is shown in Figure 3-18, and description is provided in Table 3-9.

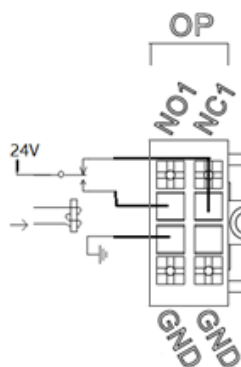

Figure 3-18 Battery warning dry contact interface diagram

Table 3-9 Battery warning dry contact interface description

Port	Name	Function
OP-NC1	BCB Drive_NC	Battery voltage warning relay (normally closed) will be open during warning
OP-NO1	BCB Drive_NO	Battery voltage warning relay (normally open) will be closed during warning
OP-GND	GND	Internal output dry contact GND

 **Note**

OP-2, OP-3 for the connection diagram of the output dry contact, refer to OP-1.

Utility Fail Warning Output Dry Contact Interface

The default function of OP-4 is the output dry contact interface for utility failure warning, when the utility fails, the system will send a utility failure warning information, and provide an auxiliary dry contact signal via the isolated relay. The interface diagram is shown in Figure 3-19, and description is provided in Table 3-10.

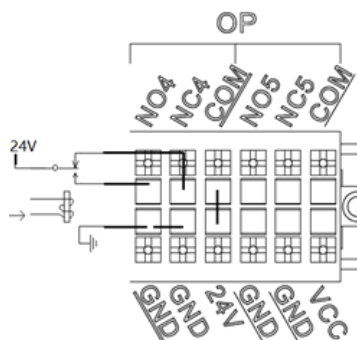

Figure 3-19 Utility failure warning dry contact interface diagram

Table 3-10 Utility failure warning dry contact interface description

Port	Name	Function
OP-NC4	UTILITY_FAIL_NC	Utility failure warning relay (normally closed) will be open during warning
OP-NO4	UTILITY_FAIL_NO	Utility failure warning relay (normally open) will be closed during warning
OP-GND	GND	Output dry contact GND

Overload Alarm Input Dry Contact Interface

The default function of OP-4 is the output dry contact interface for overload alarm, when the ups is overload, the system will send an overload alarming information, and provide an auxiliary dry contact signal via the isolated relay. The interface diagram is shown in Figure 3-20, and description is provided in Table 3-11.

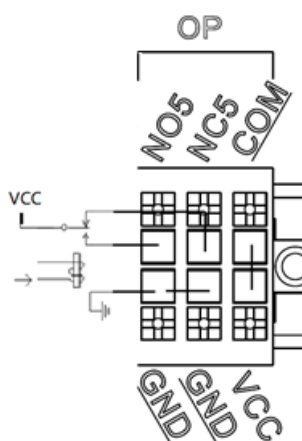

Figure 3-20 Overload alarm input dry contact interface diagram

Table 3-11 Overload alarm input dry contact interface description

Port	Name	Function
OP-NC5	Overload_NC	Overload Alarm relay (normally closed) will be open during warning
OP-NO5	Overload_NO	Overload Alarm relay (normally open) will be close during warning
OP-GND	GND	Output dry contact GND

3.7.2. Communication Interface

CAN, RS485 and USB port: Provide serial data which can be used for commissioning and maintenance by authorized engineers or can be used for networking or integrated monitoring system in the service room.

SNMP Card: Used on site installation for communication (optional).

AS400 Card: Dry contact extension interface (optional).

Expansion RS485 Card: Used for communication with BMS (optional).

4. Control and Display Panel

4.1. Cabinet Display panel

The panel is located on the front door. According to the function, it can be divided into two parts: control button and LCD display area; the structure is shown as Figure 4-1:

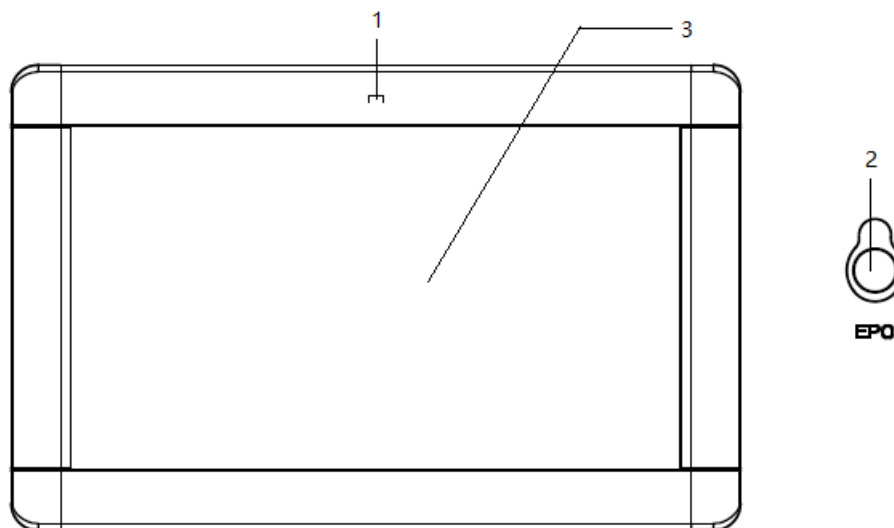

1: Screen power indicator light

2: EPO switch

3: LCD touch screen

Figure 4-1 Control and display panel

4.1.1. Audible Alarm Indication

There are two different types of audible alarm during UPS operation, as provided in Table 4-1.

Table 4-1 Description of audible alarm

Alarm	Description
Two short alarm with a long one	When system has general alarm (for example: AC fault)
Continuous alarm	When system has serious faults (for example: EOD or hardware failure)

4.1.2. Control Operation Key

Table 4-2 Functions of control and operation keys

Function Key	Description
EPO	Long press, cut off the load power, shut down the rectifier, inverter, static bypass and battery

4.1.3. LCD Touch Screen

After the monitoring system starts self-test, the system enters the home page, following the welcome window. Then 3s later, enter the home page. The home page is shown in Figure 4-2:

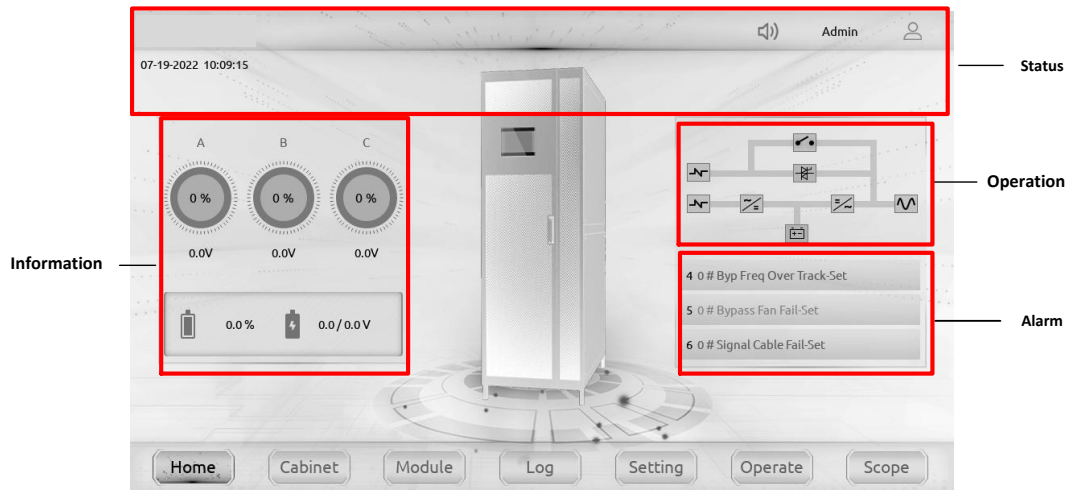

Figure 4-2 Home page

The home page mainly includes status information, information display, state of operation, alarm display, and main menu.

- **Status bar**

The Status bar contains the model of the product; Parallel operational mode and the number of the power module, the time of the system and user account login.

- **Information display**

Users can check the information of the cabinet in this area.

The load percentage is shown as a dial image. Load voltage, battery voltage and capacity are displayed numerically.

The size of the load rate of the system is indicated by the meter chart, and the load rate is displayed as a percentage value in the meter chart. The green area stands for a load of less than 60%, yellow area for a load of 60%-100% and red area for a load of more than 100%.

- **Running status**

The visualized image display the status of each part of the UPS system, green indicates that the power module is running normally, white indicates that it is not started, red indicates that the function of the part is missing (such as battery red, indicating that the battery is not connected to the system), green energy flow indicates that the module has energy output.

- **Warning information**

Display the warning information of the cabinet.

- **Main menu**

The main menu displays UPS status information, fault alarm information, and related settings. The main menu includes Cabinet, Power module, Setting, Log, Operate and Scope. The structure of the main menu tree is shown in Figure 4-3.

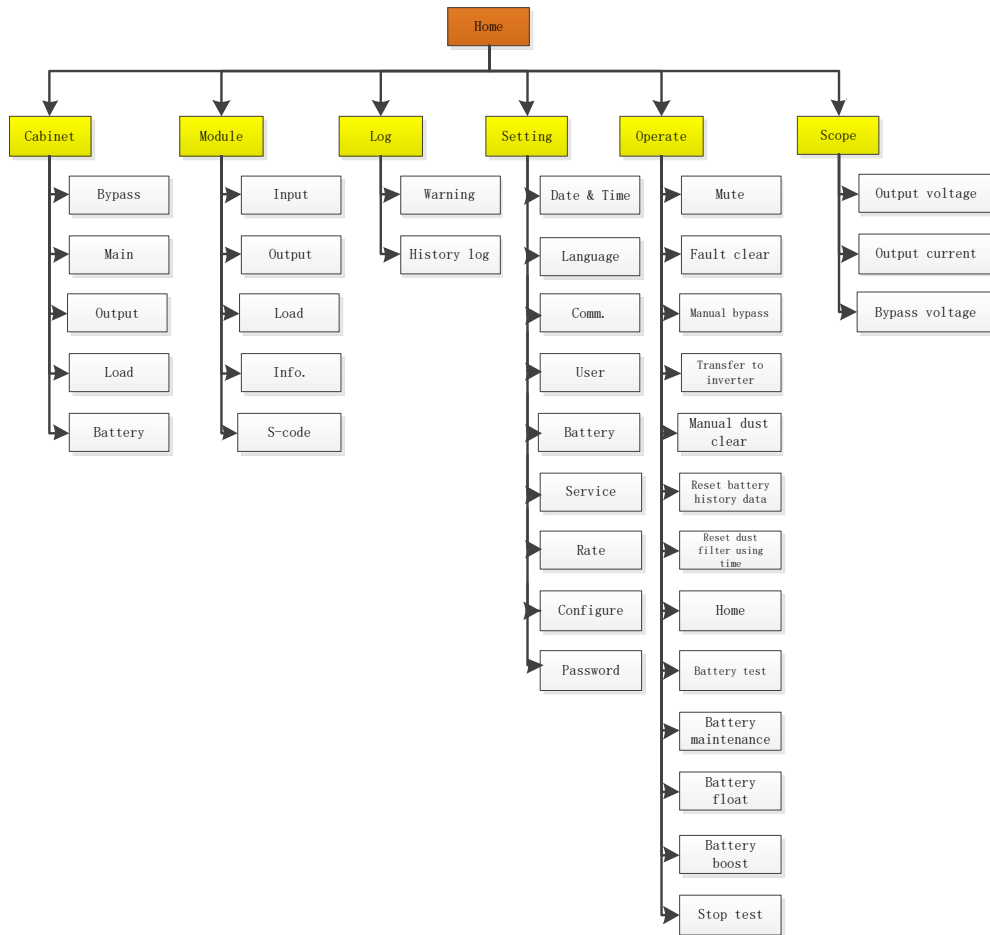

Figure 4-3 Structure of menu tree

4.2. Main Menu

The main menu includes Cabinet, Power module, Setting, Log, Operate and Scope.

4.2.1. Cabinet

After entering the home page, touch the icon **Cabinet** (at the bottom left of the screen). The system enters the page of the Cabinet, as shown in Figure 4-4.

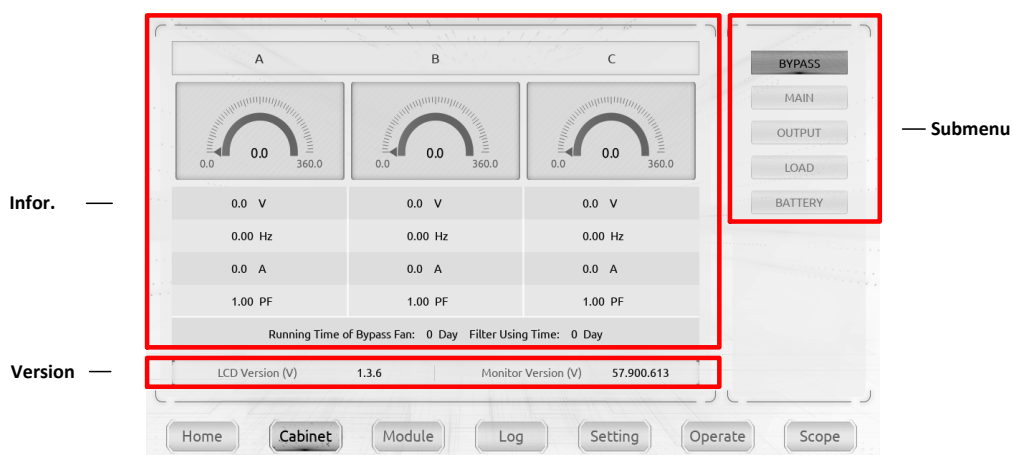

Figure 4-4 Cabinet

The Cabinet comprises sectors of title, information display, version running status, information of submenu. The sectors are described as follows:

- **Title**

Indicate that the bypass of the cabinet is selected.

- **Version information**

The software version of LCD screen and monitoring module.

- **Information display**

Visually display the voltage of each phase through a dynamic dial.

It is mainly used to display the voltage (V), current (A), frequency (Hz), and power factor (PF) of the bypass three-phase, the running time of the bypass fan and dust net.

- **Submenu**

It mainly includes submenus such as Bypass, Main, Output, Load, Battery, etc.

Click the submenu icon to enter the corresponding interface, as shown in Figure 4-5.

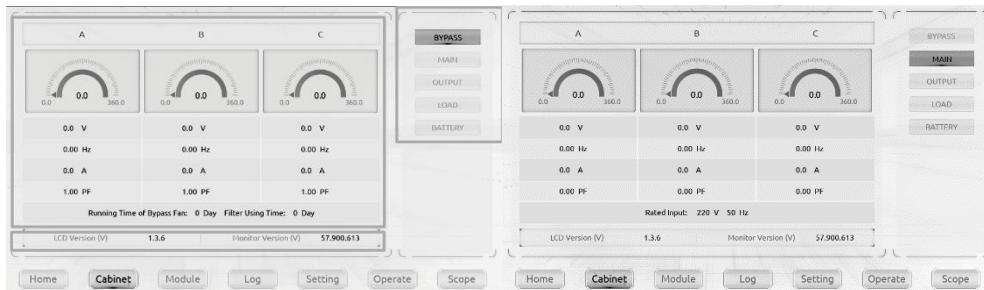

(a) Bypass

(b) Main

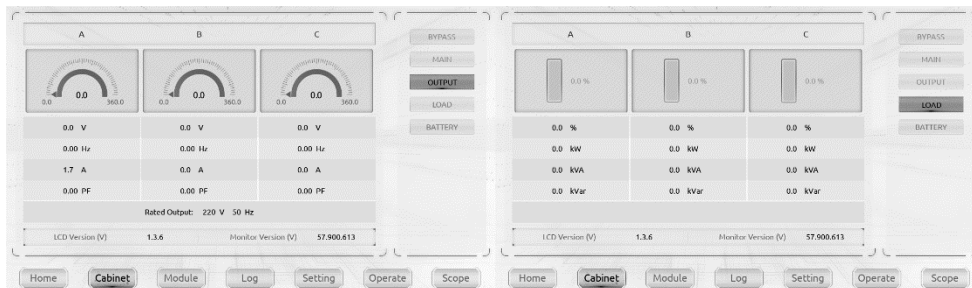

(c) Output

(d) Load

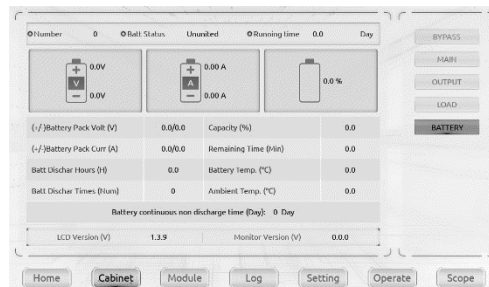

(e) Battery

Figure 4-5 Cabinet submenus

The submenus of Cabinet are described in details below in Table 4-3.

Table 4-3 Cabinet submenus

Submenu name	Contents	Meaning
Bypass	V	Phase voltage
	Hz	Bypass frequency
	A	Phase current
	PF	Power factor
Main	V	Phase voltage
	Hz	Input frequency
	A	Phase current
	PF	Power factor
Output	V	Phase voltage
	Hz	Output frequency
	A	Phase current
	PF	Power factor
Load	%	Load (The percentage of the UPS load)
	kW	Pout: Active Power
	kVA	Sout: Apparent Power
	kVAR	Qout: Reactive power
Battery	Number	Battery number
	Battery status	Battery connection status
	Battery Running T (Day)	Battery running time (Day)
	V	Battery positive / negative Voltage
	A	Battery positive / negative Current
	Battery discharging time (H)	Battery discharging time (H)
	Num	Battery discharge number (Num)
	Capacity (%)	The percentage compared with new battery capacity
	Remain T (Min)	Remaining battery backup time
	Battery (°C)	Battery Temperature
	Ambient (°C)	Environmental Temperature
	Battery Continuous non discharge T (Day)	Continuous non discharge time of the battery (Day)

4.2.2. Module

Touch the icon  (at the bottom left of the screen). The system enters the page of the Power module unit, as shown in Figure 4-6:

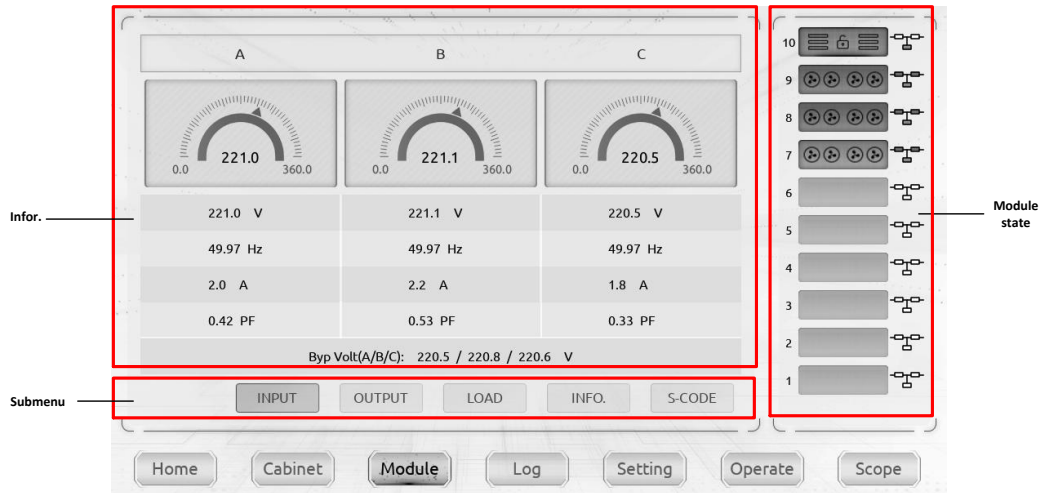

Figure 4-6 Module

The main page of module menu mainly includes information display, power module status display and power module sub-menu.

- **Information display**

Display the corresponding information of the selected power module, mainly including voltage, frequency, current, and power factor.

- **Power module information**

- (1) Power module numbers, numbered 1-10 from bottom to top.
- (2) Whether the power module is inserted and selected.

After the module is inserted and the communication connection is normal, the module icon will be displayed on the corresponding ID number.

After the module is selected, the colour of the module changes dark.

- (3) Power module operating status as follows:

- (a) The green square indicating the power module working normally.
- (b) The black indicates that the corresponding part of the power module is invalid.
- (c) The red indicating the absence of the power module or in fault.

- **Submenu**

The submenus include Input, Output, Load, INFO and S-CODE. Each interface of the submenu is shown in Figure 4-7:

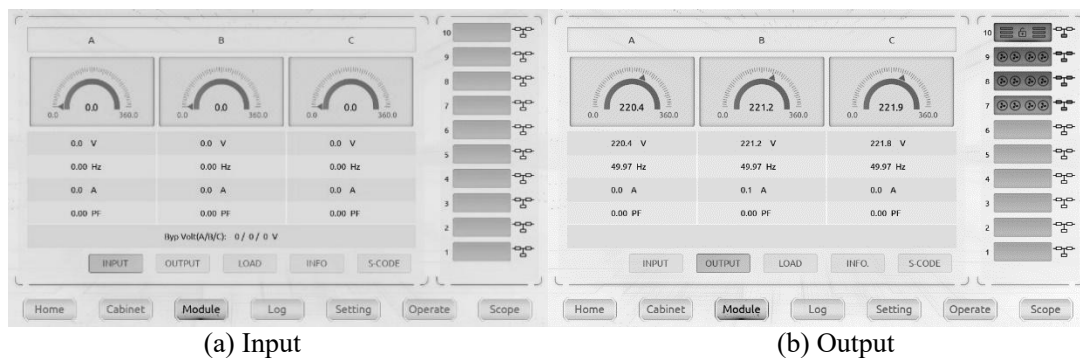

(a) Input

(b) Output

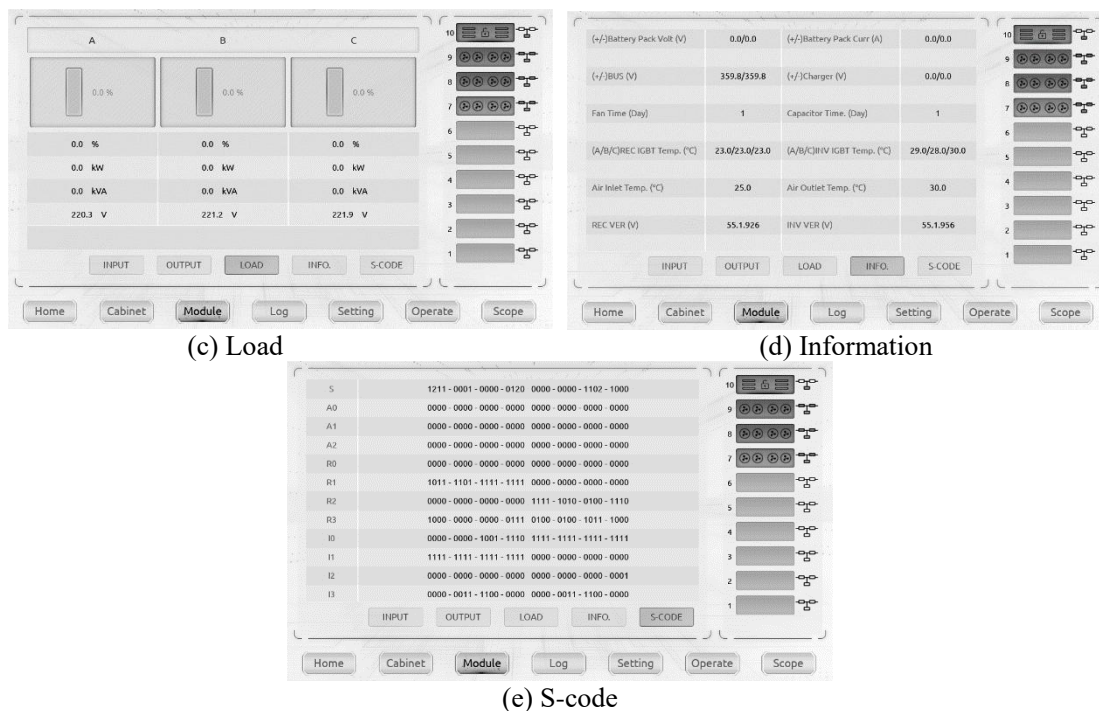



Figure 4-7 Module submenus

The Module submenus are described below in details in Table 4-4.

Table 4-4 Module submenus

Submenu Name	Contents	Meaning
Input	V	Phase voltage of selected module
	Hz	Frequency of selected module
	A	Phase current of selected module
	PF	Power factor of selected module
Output	V	Output phase voltage of selected module
	Hz	Output frequency of selected module
	A	Output phase current of selected module
	PF	Output power factor of selected module
Load	%	Load (The percentage of the power module selected)
	KW	Pout: Active Power
	KVA	Sout: Apparent Power
	V	Load voltage of selected module
Information	BATT+(V)	Battery Voltage (positive)
	BATT-(V)	Battery Voltage (negative)
	BUS(V)	Bus Voltage (Positive & Negative)
	Charger(V)	Charger Voltage(Positive & Negative)
	Fan Time	Total Fan's Running time of the selected power module
	Capacitance Time	Total Capacitance's Running time of the selected power module
	Inlet Temperature (°C)	Inlet Temperature of the selected power module
	Outlet Temperature (°C)	Outlet Temperature of the selected power module
	REC (V)	The module rectifier software version
INV (V)	The module inverter software version	
S-code	Fault Code	For the maintenance personnel

4.2.3. Log

Touch the icon  (at the bottom of the screen). The system enters the page of the Log, as shown in Figure 4-8. The log page mainly includes the display of current warning information and historical records. The submenus of Log are described in details below in Table 4-5.

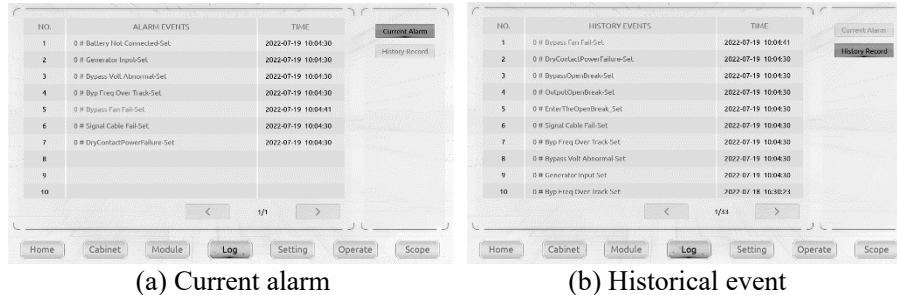

(a) Current alarm

(b) Historical event

Figure 4-8 Log submenus

The following Table 4-5 gives the complete list of all the UPS events displayed by history record window and current record window.

Table 4-5 UPS event list

UPS events	Description
Load On UPS	The system is in normal inverter power supply
Load On Bypass	The system is in bypass power supply
No Load	No system output
Battery Boost	Charger is working in boost charging mode
Battery Float	Charger is working in float charging mode
Battery Discharge	Battery is discharging
Battery Connected	Battery is connected already
Battery Not Connected	Battery is not yet connected.
Maintenance CB Closed	Manual maintenance breaker is closed
Maintenance CB Open	Manual maintenance breaker is opened
EPO (Set)	Emergency Power Off
EPO (Disappear)	None Emergency Power Off
Module On Less (Set)	Inverter output module capacity is less than the load capacity
Module On Less (Disappear)	Inverter output module capacity is more than the load capacity
Generator Input (Set)	External generator is connected
Generator Input (Disappear)	Disconnect the external generator after it is connected
Utility Abnormal (Set)	Utility (Grid) is abnormal
Utility Abnormal (Disappear)	Utility recover normal
Bypass Sequence Error (Set)	Bypass voltage Sequence is reverse
Bypass Sequence Error (Disappear)	Bypass voltage Sequence recover normally
Bypass Volt Abnormal (Set)	Bypass voltage is abnormal
Bypass Volt Abnormal (Disappear)	Bypass voltage is abnormal recover normally
Bypass Module Fail (Set)	Bypass module fails
Bypass Module Fail (Disappear)	Bypass module recover normally
Bypass Module Over Load (Set)	Bypass current is over the limitation.
Bypass Module Over Load (Disappear)	Bypass current recover normally

UPS events	Description
Bypass Over Load Tout (Set)	The bypass overload status continues and the overload times out
Bypass Over Load Tout (Disappear)	The bypass overload status continues and the overload times out off
Byp Freq Over Track (Set)	Bypass frequency is out of tracking range
Byp Freq Over Track (Disappear)	Bypass frequency recovery tracking range
Exceed Tx Times Lmt (Set)	The number of transfer between bypass and inverter exceeds five in the last hour
Exceed Tx Times Lmt (Disappear)	Clear transfer times
Output Short Circuit (Set)	Output shorted Circuit
Output Short Circuit (Disappear)	Output shorted Circuit disappear
Battery EOD (Set)	The battery voltage reaches the battery EOD
Battery EOD (Disappear)	The battery voltage is restored above the battery EOD
Battery Test	System transfer to battery self-test mode
Battery Test OK	Battery Test OK
Manual battery Test Fail	The system detects that the battery is faulty
Battery Maintenance	The system is in battery maintenance status
Battery Maintenance OK	Battery maintenance succeed
Battery Maintenance Failed	Battery maintenance unsucceed
Stop Test	Battery self-test or battery maintenance status terminate
Fault Clear	Clear the reported failure
History clear	Delete all history records
N#Module Inserted	The N# Power Module is inserted in system.
N#Module Exit	The N# Power Module is pulled out from system.
N#Rectifier Fail (Set)	The N# Power Module Rectifier Fail
N#Rectifier Fail (Disappear)	The N# Power Module Rectifier Fail removed
N#Inverter Fail (Set)	The N# Power Module Inverter Fail
N#Inverter Fail (Disappear)	The N# Power Module Inverter Fail removed
N#Rectifier Over Temp (Set)	The N# Power Module Rectifier Over Temperature
N#Rectifier Over Temp (Disappear)	The N# Power Module Rectifier Over Temperature Disappear
N#Fan Fail (Set)	The N#At least one fan fails, failed connection or blocked rotation
N#Fan Fail (Disappear)	The N# Fans recover normal
N#Output Over Load (Set)	The N# Power Module Output Over Load
N#Output Over Load (Disappear)	The N# Power Module Output Recover
N#Inverter Overload Tout (Set)	The N# Power Module Inverter Over Load Timeout
N#Inverter Overload Tout (Disappear)	The N# Power Module Inverter Over Load Timeout Over
N#Inverter Over Temp (Set)	The N# Power Module Inverter Over Temperature
N#Inverter Over Temp (Disappear)	The N#Power Module Inverter Over Temperature Disappear
On UPS Inhibited (Set)	Inhibit system transfer from bypass to inverter
On UPS Inhibited (Disappear)	Inhibit system transfer from bypass to inverter Disappear
Manual Transfer Byp	Transfer to bypass manually
Esc Manual Bypass	Escape from “transfer to bypass manually” command.
Battery Volt Low (Set)	Battery Voltage is Low
Battery Volt Low (Disappear)	Battery Voltage recover normal

UPS events	Description
Battery Reverse (Set)	Battery cables are connected not correctly
Battery Reverse (Disappear)	Battery cables are connected correctly
N#Inverter Protect (Set)	The N#Power Module Inverter Protect
N#Inverter Protect (Disappear)	The N# Power Module Inverter Protect removed
Input Neutral Lost	The utility neutral wire is lost or not detected
Bypass Fan Fail (Set)	At least one of bypass module Fans Fails
Bypass Fan Fail (Disappear)	Bypass module Fans Fails removed
N#Manual Shutdown	The N# Power Module is manually shutdown
Manual Boost Charge	Manually force the Charger work in boost charge mode
Manual Float Charge	Manually force the charger work in float charge mode
UPS Locked	Forbidden to shutdown UPS power module manually
Parallel Cable Error (Set)	Parallel cables error
Parallel Cable Error (Disappear)	Parallel cables error disappear
Cumulative time of This Time	Cumulative time of this time
N#Battery Or Charger Malfunction (Set)	The N#Power module battery or charger malfunction
N#Battery Or Charger Malfunction (Disappear)	The N#Power module battery or charger malfunction removed
Lost N+X Redundant (Set)	Cabinet lost N+X Redundant
Lost N+X Redundant (Disappear)	Cabinet recover N+X Redundant
EOD Sys Inhibited (Set)	
EOD Sys Inhibited (Disappear)	
Signal Wire Connection Malfunction (Set)	Signal wire connection malfunction
Signal Wire Connection Malfunction (Disappear)	Signal wire connection malfunction removed
Ambient Over Temp (Set)	Ambient temperature is over the limit of UPS
Ambient Over Temp (Disappear)	Ambient temperature recover normal
REC CAN Fail (Set)	Rectifier CAN bus communication is abnormal
REC CAN Fail (Disappear)	Rectifier CAN bus communication recover normal
INV IO CAN Fail (Set)	IO signal communication of inverter CAN bus is abnormal
INV IO CAN Fail (Disappear)	IO signal communication of inverter CAN bus recover normal
INV DATA CAN Fail (Set)	DATA communication of inverter CAN bus is abnormal
INV DATA CAN Fail (Disappear)	DATA communication of inverter CAN bus recover normal
N#Power Share Fail (Set)	The difference of the N# power modules' output current in system is over limitation
N#Power Share Fail (Disappear)	The difference of the N# power modules' output current in system recover normal
N#Sync Pulse Fail (Set)	The N# Synchronization signal between modules is abnormal
N#Sync Pulse Fail (Disappear)	The N# Synchronization signal between modules recover normal
N#Input Volt Detect Fail (Set)	Input voltage of N# power module is abnormal
N#Input Volt Detect Fail (Disappear)	Input voltage of N# power module recover normal

UPS events	Description
N#Battery Volt Detect Fail (Set)	The N# Power module detect that battery voltage is abnormal
N#Battery Volt Detect Fail (Disappear)	The N#Power module detect that battery voltage recover normal
N#Output Volt Detect Fail (Set)	The N#Power module output voltage is abnormal
N#Output Volt Detect Fail (Disappear)	The N#Power module output voltage recover normal
N#Byb Volt Detect Fail (Set)	The N#Power module detect that bypass voltage is abnormal
N#Byb Volt Detect Fail (Disappear)	The N#Power module detect that bypass voltage recover normal
N#INV Bridge Fail (Set)	The N# Power module inverter is failure
N#INV Bridge Fail (Disappear)	The N#Power module inverter failure removed
N#Outlet Temp Error (Set)	Outlet temperature of N# power module is over the limitation
N#Outlet Temp Error (Disappear)	Outlet temperature of N# power module recover normal
N#Input Curr Unbalance (Set)	The three-phase input current of the N# power module is different
N#Input Curr Unbalance (Disappear)	The three-phase input current of the N# power module recover normal
N#DC Bus Over Volt (Set)	The N# Power module Voltage of DC bus capacitors is over limitation
N#DC Bus Over Volt (Disappear)	The N#Power module Voltage of DC bus capacitors recover normal
N#REC Soft Start Fail (Set)	The N#Power module rectifier can't start
N#REC Soft Start Fail (Disappear)	The N#Power module rectifier recover normal
N#Relay Connect Fail (Set)	The N# Power module inverter relay can't close
N#Relay Connect Fail (Disappear)	The N#Power module inverter relay is closed
N#Relay Short Circuit (Set)	The N#Power module Inverter relays are shorted
N#Relay Short Circuit (Disappear)	The N#Power module Inverter relays don't shorted
N#PWM Sync Fail (Set)	The N#Power module rectifier and inverter PWM synchronizing signal is abnormal
N#PWM Sync Fail (Disappear)	The N#Power module rectifier and inverter PWM synchronizing signal recover normal
N#Intelligent Sleep (Set)	The N#Power module works in intelligent sleep mode
N#Intelligent Sleep (Disappear)	The N#Power module exits intelligent sleep mode
Manual Transfer to INV	The N#Manually transfer UPS to inverter
N#Input Over Curr Tout (Set)	The N# Power module Input over current timeout
N#Input Over Curr Tout (Disappear)	The N# Power module Input over current timeout disappear
N#No Inlet Temp. Sensor (Set)	The N#Power module Inlet temperature sensor is not connected correctly or open
N#No Inlet Temp. Sensor (Disappear)	The N#Power module Inlet temperature sensor recover normal
N#No Outlet Temp. Sensor (Set)	The N#Power module outlet temperature sensor is not connected correctly or open
N#No Outlet Temp. Sensor (Disappear)	The N#Power module outlet temperature sensor recover normal

UPS events	Description
N#Inlet Over Temp. (Set)	The N#Power module Inlet air is over temperature
N#Inlet Over Temp. (Disappear)	The N#Power module Inlet air temperature recover normal
N#Capacitor Time Reset	The N#Power module reset timing of DC bus capacitors
N#Fan Time Reset	The N#Power module reset timing of fans
Battery History Reset	Reset battery history data
Battery Over Temp. (Set)	Battery is over temperature
Battery Over Temp. (Disappear)	Battery temperature recover normal
Bypass Fan Expired (Set)	Working life of bypass fans is expired
Bypass Fan Expired (Disappear)	Working life of bypass fans isn't expired
N#Capacitor Expired (Set)	The N#Power module Working life of capacitors is expired
N#Capacitor Expired (Disappear)	The N#Power module Working life of capacitors isn't expired
N#Fan Expired (Set)	The N#Power module Working life of power modules' fans is expired
N#Fan Expired (Disappear)	The N#Power module Working life of power modules' fans isn't expired
N#INV IGBT Driver Block (Set)	The N#Power module Inverter IGBTs are shutdown
N#INV IGBT Driver Block (Disappear)	The N#Power module Inverter IGBTs aren't shutdown
Dust Filter Expired (Set)	Dust filter need to be clear or replaced with a new one
Dust Filter Expired (Disappear)	Dust filter don't need to be clear or replaced with a new one
Battery Expired (Set)	Working life of batteries is expired
Battery Expired (Disappear)	Working life of batteries isn't expired
BMS Communication Fair (Set)	BMS Communication fair
BMS Communication Fair (Disappear)	BMS Communication fair removed
CAN Communication Fair (Set)	Monitoring unit CAN communication failure
CAN Communication Fair (Disappear)	Monitoring unit CAN communication recover normal
Single Cell under Volt Fair (Set)	Single Cell voltage is low
Single Cell under Volt Fair (Disappear)	Single Cell voltage recover normal
Single Cell over Volt Fair (Set)	Single Cell voltage is high
Single Cell over Volt Fair (Disappear)	Single Cell voltage recover normal
Single Cell Volt Fair (Set)	Single Cell Voltage is excessive difference
Single Cell Volt Fair (Disappear)	Single Cell Voltage recover normal
Battery Low Ambient Temp (Set)	Battery Ambient temperature is low
Battery Low Ambient Temp (Disappear)	Battery Ambient temperature recover normal
Battery Over Ambient Temp (Set)	Battery Ambient temperature is over the limitation
Battery Over Ambient Temp (Disappear)	Battery Ambient temperature recover normal
BMS Forbid Charging (Set)	BMS system forbid battery charging
BMS Forbid Charging (Disappear)	BMS system recover charging battery
BMS Forbid Discharging (Set)	BMS system forbid battery discharging
BMS Forbid Discharging (Disappear)	BMS system recover discharging battery
Wave Trigger	Waveform has been saved while UPS fail
Bypass CAN Fail (Set)	Monitoring unit Bypass CAN signal is abnormal

UPS events	Description
Bypass CAN Fail (Disappear)	Monitoring unit Bypass CAN signal recover normal
Bypass Power Fuse Fair (Set)	Bypass Power fuse break
Bypass Power Fuse Fair (Disappear)	Bypass Power fuse is normal
N#Software Version Error (Set)	The N#Power module software version error
N#Software Version Error (Disappear)	The N#Power module software version update to normal version
System Setting Data Error	System setting data error
Bypass Over Temp (Set)	Bypass module is over temperature
Bypass Over Temp (Disappear)	Bypass module temperature recover normal
N# Module ID Duplicate (Set)	At least one N# module is set as same ID with other module on the power connector board
N# Module ID Duplicate (Disappear)	The N# power module ID is normal after the change.
Electrolyte Leakage (Set)	The battery electrolyte is leakage
Electrolyte Leakage (Disappear)	The battery leakage alarm is cleared



Note

- Different colors of the words represent different levels of events: Green, a normal event occur; Grey, the event occurs then clears; Yellow, warning occurs; Red, faults happen.
- Generally, "Set" refers to the occurrence of an event or corresponding operation. "Disappear" refer to the event is removed or the fault is cleared.

4.2.4. Setting

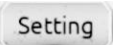
Touch the icon  (at the bottom of the screen). The system enters the page of the Setting, as shown in figure 4-9:

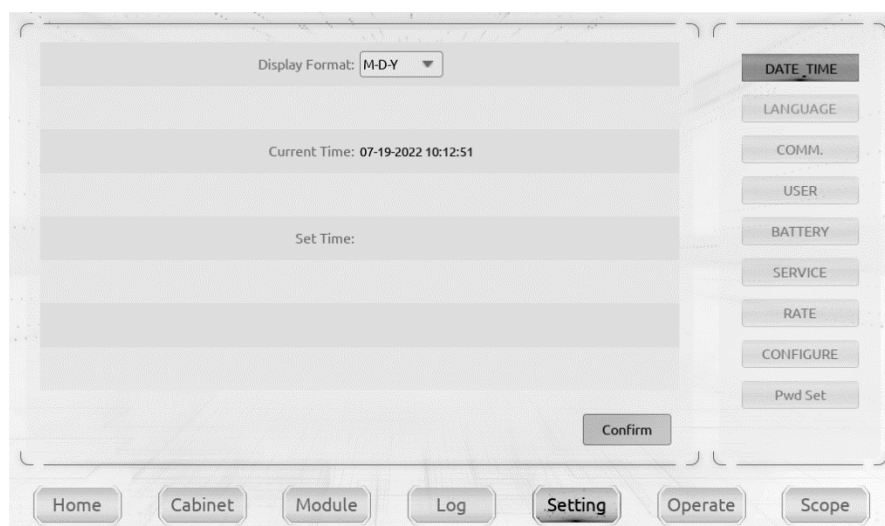

Figure 4-9 Setting

The submenus are described in details below in Table 4-6:

Table 4-6 Setting submenus

Submenu Name	Contents	Meaning
Date & Time	Date format setting	Three formats: year/month/day, month/date/year, date/month/year
	Time setting	Set the date and time according to the selected date format
Language	Current language	Language in use
	Language selection	Simplified Chinese and English, etc. (selectable)
COMM.	Device Address	Setting the communication address
	USB, RS485, SNMP Protocol selection	SNT Protocol, Modbus Protocol, YD/T Protocol and Dwin (For factory use)
	Baud rate	Setting the baud rate of SNT, Modbus and YD/T
	Modbus Mode	Setting mode for Modbus: ASCII and RTU selectable
	Modbus parity	Setting the parity for Modbus
USER	Output voltage adjustment	Setting the output voltage
	Bypass Voltage Up limited	Up limited working voltage for bypass, settable:+10%, +15%, +20%, +25%
	Bypass Voltage Down limited	Down limited working voltage for bypass, settable:-10%, -15%, -20%, -30%, -40%
	Bypass Frequency Limited	Permitted working frequency for bypass Settable: +-1Hz, +-3Hz, +-5Hz
	Title modification	Modify the software three-phase display title, such as A-B-C, R-S-T, U-V-W, L1-L2-L3
	LCD Time	Set the time of LCD screen saver
	LOGO Show Time	Set logo page show time
BATTERY	Battery Type	Display battery type, such as Lead-acid or lithium battery
	Battery Number	Setting the number of the battery
	Battery Capacity	Setting of the AH of the battery
	Float Charge Voltage/Cell	Setting the floating Voltage for battery cell
	Boost Charge Voltage/Cell	Setting the boost Voltage for battery cell
	EOD (End of discharge) Voltage/Cell, @0.6C Current	EOD voltage for cell battery, @0.6C current
	EOD (End of discharge) Voltage/Cell, @0.15C Current	EOD voltage for cell battery, @0.15C current

Submenu Name	Contents	Meaning
	Charge Current Percent Limit	Charge current (percentage of the rated current)
	Battery Temperature Compensate	Coefficient for battery temperature compensation
	Boost Charge Time Limit	Setting boost charging time
	Auto Boost Period	Setting the auto boost period
	Auto Maintenance Discharge Period	Setting the period for auto maintenance discharge
Service	System Mode	System mode setting, such as single, parallel, single ECO, parallel ECO, LBS, parallel LBS. Self-aging can't be set
	United Number	Set the number of UPS in parallel system
	System ID	Set the ID of UPS in parallel system
	Frequency Slew Rate	Set the slew rate of track
	Dust Filter Maintenance Period	Set the dust filter maintenance period
	Frequency Slew Limit	Set the frequency rate limitation
	Redundant Module Number	Set the redundant module number
	Battery Transfer to Main Delay	Set the delay time from battery transfer to main
	System Auto Start Mode after EOD	Set the System startup mode after EOD
Rated	Cabinet Capacity	Set the UPS total capacity
	Power Module Capacity	Set the single power module capacity
	Rated Input Voltage	Set the rated input voltage
	Rated Input Frequency	Set the rated input frequency
	Rated Output Voltage	Set the rated output voltage
	Rated Output Frequency	Set the rated output frequency
CONFIGURE	System configuration	Configuring system parameters
Password	Change the password of the login account	Change the passwords of the current user and the user with lower privileges. The password recovery function sets the passwords of all login accounts to the initial values

 **Note**

- Set the time setting, language setting, and communication setting in the subordinate submenu, which can be set by the user; User settings require a first-level password,

which needs to be set by professional personnel; Battery setting and service setting require a secondary password for after-sales service; Rated setting, system configuration factory setting, rated setting requires a three-level password, system setting requires a four-level password.

- The C of the battery setting is the ampere hour of the battery, if it is a 100AH battery, then $C=100A$.



Warning

Ensure the number of the battery is completely equal to the real installed number. Otherwise it will cause serious damage to the batteries or the equipment.

4.2.5. Operate

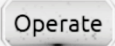
Touch the icon  (at the bottom of the screen). The system enters the page of the Operate, as shown in Figure 4-10.

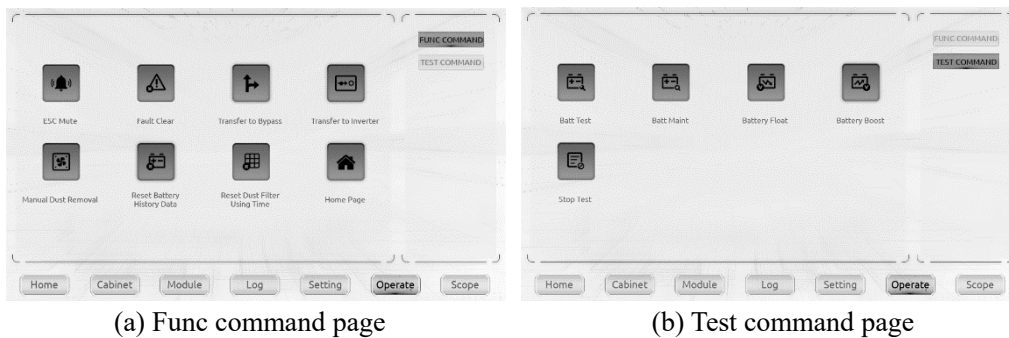

(a) Func command page



(b) Test command page

Figure 4-10 Operate

The “Operate” menu includes Function button page and Test command page. The contents are described in details below.

Function Button

- **Clear/Restore Buzzing**

Touch the icon  or  to mute or restore buzzing of the system.

- **Fault Clear**

Touch the icon  to execute the fault clear.

- **Transfer to and ESC Bypass**

Touch the icon  or  to transfer to bypass mode or cancel.

- **Manual Transfer to Inverter**

Touch the icon  to transfer to inverter mode.

- **Manual Dust Clear**

Touch the icon , the UPS start to dust clear.

- **Reset Battery History Data**

Touch the icon , reset the battery history data, includes the times of discharge, days for running and hours of discharging.

- **Reset Dust filter Using Time**

Touch the icon , reset the time of dust filter using.

Test Command

- **Battery Test**

Touch the icon , the system transfer to the Battery mode to test the condition of the battery. Ensure the bypass working normally and capacity of the battery isn't less than 25%.

- **Battery Maintenance**

By touching the icon  partially discharge the battery, charge and discharge the battery for maintenance. The bypass must be in normal condition and should maintain more than 25% of the battery capacity. After the system reaches EOD, the discharge ends and the system transfer back to normal mode.

- **Battery Boost**

By touching the icon  the system starts boost charging.

- **Battery Float**

By touching the icon  the system starts float charging.

- **Stop Test**

By touching the icon  the system stops battery test or battery maintenance.

4.2.6. Scope

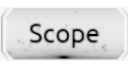
Touch the icon  (at the bottom right of the screen). The system enters the page of the scope. It mainly provides waveform diagrams of output voltage, output current, bypass voltage,

which is convenient for users to observe intuitively. As shown in Figure 4-11. Click the display item on the right, and the corresponding waveform will be displayed in the corresponding display area on the left. Yellow, green, and red represent the corresponding ABC phase, and the numbers below represent their specific values in sequence.

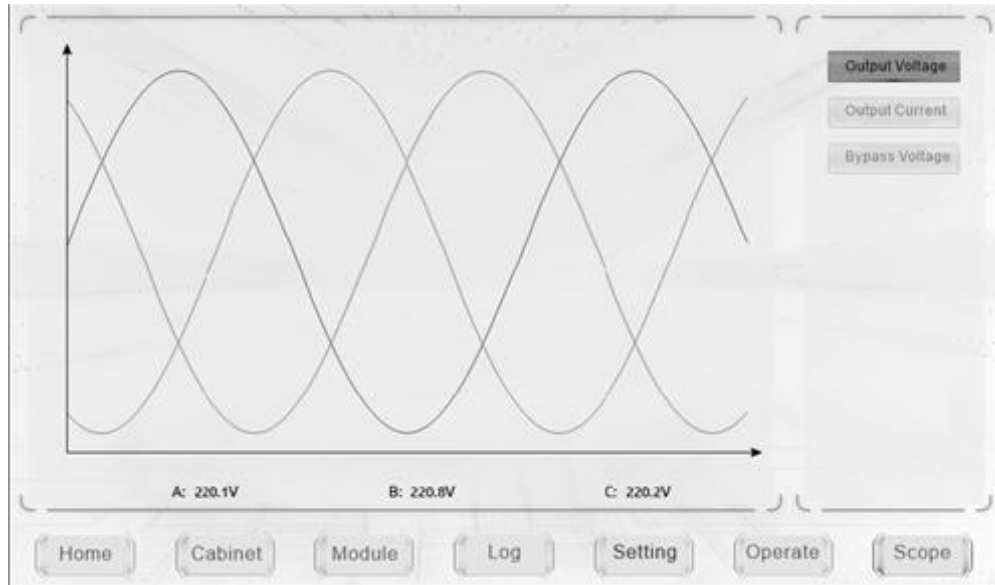

Figure 4-11 Scope

5. Operation

5.1. UPS Start-up

5.1.1. Start in Normal Mode

The UPS must be started up by commissioning engineer after the completeness of installation. The steps below must be followed:

1. Ensure all the circuit breakers are open.
2. One by one to turn on the output breaker (Q4), input breaker (Q1), bypass input breaker (Q2), and then the system starts initializing.
3. After monitoring, the LCD is lit up. The system enters the home page, as shown in Figure 4-2.
4. Notice the energy bar in the home page, and pay attention to the LED indicators. The rectifier flashes indicating the rectifier is starting up. The LED indicators are listed below in Table 5-1.

Table 5-1 Rectifier starting up

Indicator	Status	Indicator	Status
Rectifier	green flashing	Inverter	off
Battery	red	Load	off
Bypass	off	Status	red

5. After 30S, the rectifier indicator goes steady green, presenting the finishing of rectification and bypass static switch closes then the inverter is starting up. The LED indicators are listed below in Table 5-2.

Table 5-2 Inverter starting up

Indicator	Status	Indicator	Status
Rectifier	green	Inverter	green flashing
Battery	red	Load	green
Bypass	green	Status	red

6. The UPS transfers from the bypass to inverter after the inverter goes normal bypass indicator off, inverter indicator and load indicator on. The LED indicators are listed below in Table 5-3.

Table 5-3 Supplying the load

Indicator	Status	Indicator	Status
Rectifier	green	Inverter	green
Battery	red	Load	green
Bypass	off	Status	red

7. Close the battery circuit breakers, battery indicator status is green, then the UPS starts charging the battery, UPS is in Normal Mode. The LED indicators are listed below in Table 5-4.

Table 5-4 Normal mode

Indicator	Status	Indicator	Status
Rectifier	green	Inverter	green
Battery	green	Load	green
Bypass	off	Status	green

Note

- When start-up for the first time, the language, time, date and system parameters can be set through the Setting submenus. When start-up again, the system defaults to the previous Settings. If these parameters have been set, the system defaults to the existing ones.
- During start up, users can browse all events during the process of the starting up by checking the menu Log.
- During start up, users can check the information of the power module by the keys in the front of it.

5.1.2. Start from Battery

The start from battery is referring to battery cold start. The steps for the start-up are as follows:

1. Confirm the battery is correctly connected, turn on the external battery circuit breakers.
2. Press the red battery cold start button for more than 7 seconds, the system is then powered by the battery. See Figure 5-1.

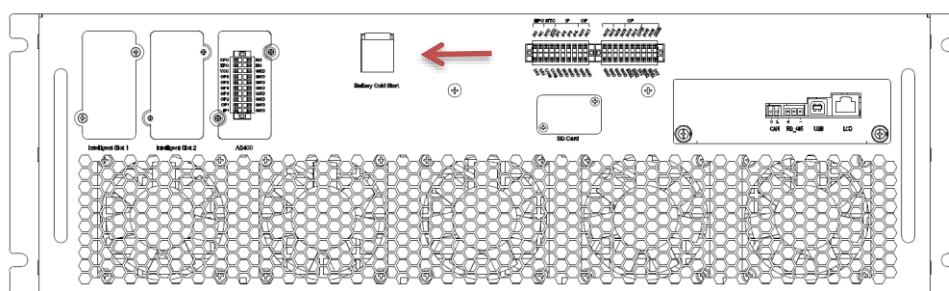

Figure 5-1 The position of the battery cold start button on cabinet



3. After that, start the system according to the steps after step 3 in normal mode. The system starts the rectifier and then the inverter to complete the inverter output. The entire process takes approximately 60 seconds and the system operates in battery mode.
4. Turn on the UPS output breaker or external output breaker to supply power to loads and finish UPS start-up in battery mode.

5.2. Operation Modes Switching

5.2.1. Switching to Battery Mode from Normal Mode

Disconnect the input breaker to cut off the utility, and the UPS enters battery mode. If you need to transfer the UPS back to normal mode, wait a few seconds before closing the input breaker and resupplying utility power. After 10 seconds, the rectifier automatically restarts and power to the inverter is restored.

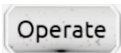
5.2.2. Switching to Bypass Mode from Normal Mode



Touch the icon  to entry submenu page, touch the icon  system transfers to bypass mode manually.



Warning

Ensure the bypass is working normally before transferring to bypass. Or it may cause failure. Manually turning off power module, make sure the remaining power module don't overload.

5.2.3. Switching to Normal Mode from Bypass Mode

Enter the menu Operate, touch the icon , entry submenu page, and touch the , system transfers to normal mode.

5.2.4. Switching to Maintenance Bypass Mode from Normal Mode

These following procedures can transfer the load from the UPS inverter output to the maintenance bypass supply, which is used for maintaining.

1. Touch the  on LCD, transfer the UPS into Bypass mode following section 5.2.2; The inverter indicator LED goes out, the buzzer alarm. The bypass supplies power to load, the inverter shutdown.
2. Turn off the external battery breaker and turn on the maintenance bypass breaker. And the load is powered through maintenance bypass and static bypass.
3. Turn off bypass breaker, utility breaker and output breaker, the maintenance bypass supplies power to loads.
4. Now we can pull out the bypass module or power module for maintenance.



Warning

Before making this operation, check LCD display to be sure that bypass supply is regular and the inverter is synchronous with it, so as not to risk a short interruption in powering the load.



Danger

If you need to maintain the power module, wait for 10 minutes to let the DC bus capacitor fully discharge before removing the cover.

5.2.5. Switching to Normal Mode from Maintenance Bypass Mode

These following procedures can transfer the load from the Maintenance Bypass to inverter output:

1. Turn on bypass breaker and output breaker, power ON, after 30S, the static bypass turns on, the



bypass indicator LED goes green, and the load is powered through maintenance bypass and static bypass.

2. Turn off the maintenance bypass breaker and the load is powered through static bypass.
3. Turn on input breaker, battery breaker, and the rectifier starts, after 30S, the rectifier finish to start; the rectifier indicator LED goes green, and then inverter start. After 60S, the system transfers to Normal mode.

5.3. Battery Test

If the battery is not in use for a long time, it is necessary to test the condition of the battery. Two methods are provided:

1. Manual Discharging test. Enter the menu Operate, as shown in Figure 5-2 and touch the icon

“Battery maintenance”  , the system transfers into the Battery mode for discharging, then the battery will have 20% of capacity or in low voltage, users can stop the discharging by touching the icon “Stop Test”  .

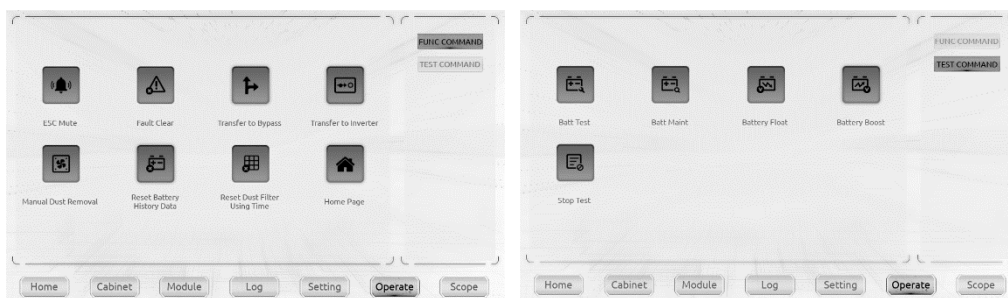

(a)Function button page (b) Test command page
Figure 5-2 Battery maintenance

2. Auto discharging. After the automatic discharge setting of the battery, the battery will automatically discharge to close to the battery low voltage and then recover. It is necessary to set automatic discharge period and enable battery maintenance. The steps are as follows:

- (1) Enter the system configuration secondary menu under the Settings submenu, select "Automatic Battery Maintenance", and confirm.
- (2) Enter the secondary menu of battery settings under the settings submenu, as shown in Figure 5-3 for automatic battery discharge period settings. Set the discharge period in the "Automatic Discharge Period" and confirm (the battery self-test period is 30-120 days, and if not set by default, the battery self-test is disabled).

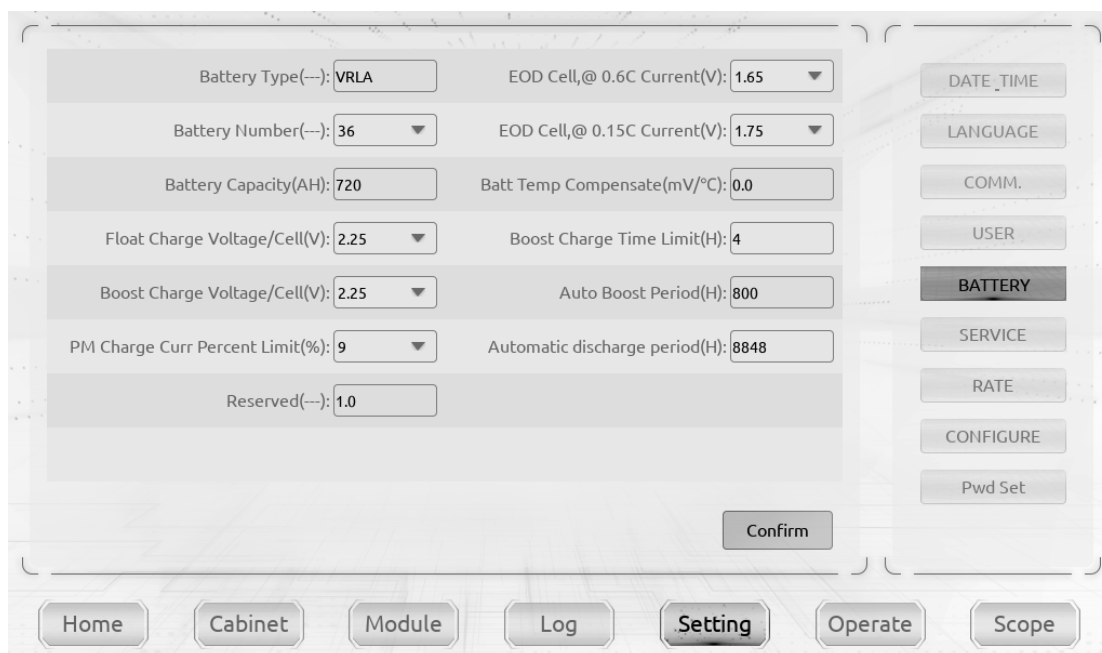

Figure 5-3 Setting period for battery auto discharge

**Warning**

The load for the auto maintenance discharge should be 20%-100%, if the load is less than 20% of the nominal capacity of the battery, automatic discharge maintenance cannot be achieved.

5.4. EPO

The EPO button is designed to switch off the UPS in emergency conditions (Such as fire, flood, etc). To achieve this, just press the EPO button, and the system will turn off the rectifier, inverter and stop powering the load immediately (including the inverter and bypass), and the battery stops charging or discharging.

As shown in Figure 5-4, open the cover of the EPO, and hold down the button for about 1 second to realize emergency stop.

If the input utility is present, the UPS control circuit will remain active; however, the output will be turned off. To completely isolate the UPS, users need to turn off the input breaker and external battery breaker supply to the UPS.

**Warning**

When the EPO is triggered, the load is not powered by the UPS. Be careful to use the EPO function.

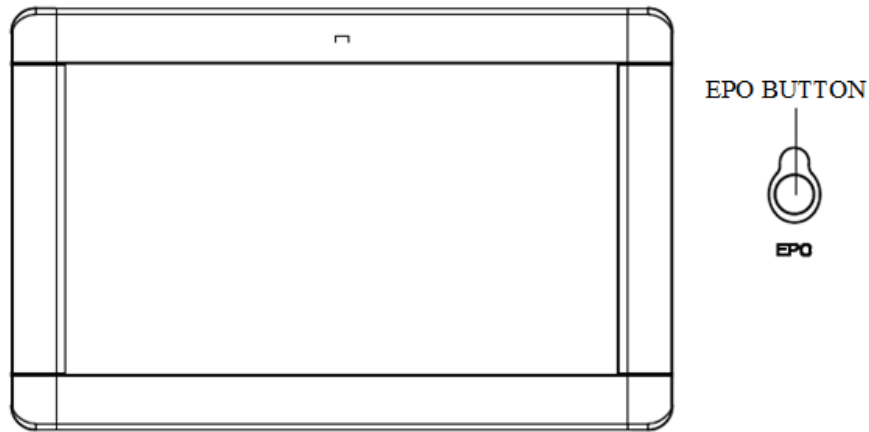

Figure 5-4 EPO button

5.5. Installation of Parallel System

The UPS system can support maximum three cabinets in parallel. Two UPS cabinets are connected as shown in Figure 5-5.

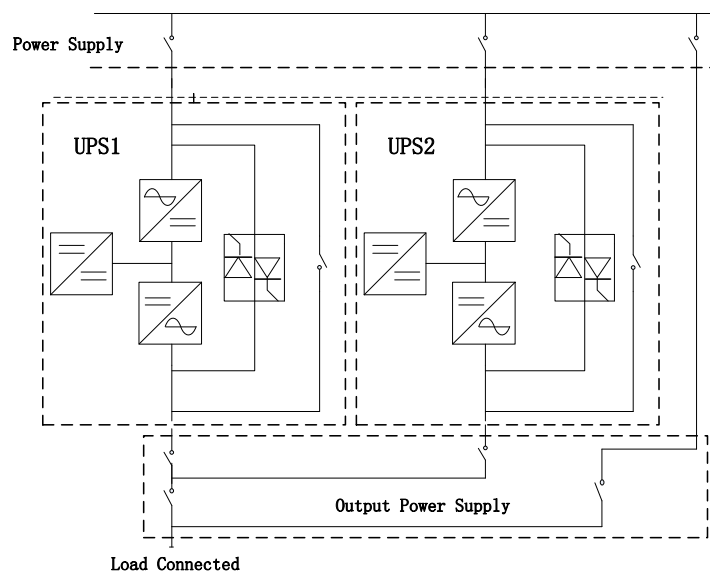

Figure 5-5 Parallel diagram

The parallel terminals of the cabinet are located inside the cabinet and can be seen by opening the back panel. Its position is shown at A in Figure 5-6:

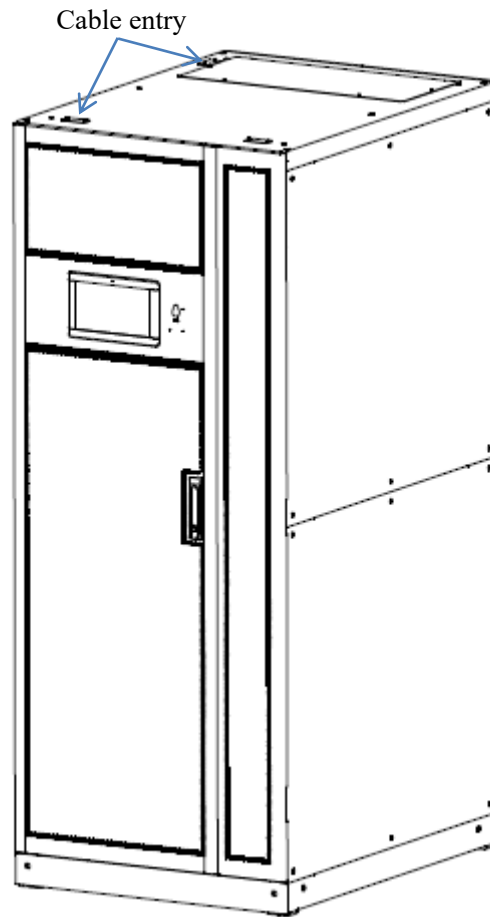

Figure 5-6 Location of the parallel interface

The control cables for the parallel operation must be connected with all single devices to form a closed loop, as shown in Figure 5-7.

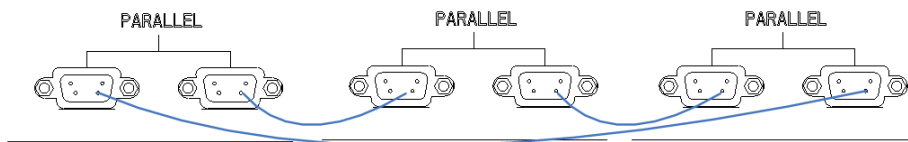

Figure 5-7 Parallel connection

For more details of parallel operation, please refer to the “Instruction for Parallel Operation”.

6. Maintenance

6.1. Contents of This Chapter

This chapter introduces UPS maintenance, including the maintenance instructions of power module, monitoring bypass module and the battery group.

6.2. System Maintenance Instruction

6.2.1. Precautions

Only maintaining engineers can maintain the power module, monitoring bypass module.

1. The power module should be disassembled from top to bottom, so as to prevent any inclination from high gravity center of the cabinet.
2. To ensure the safety before maintaining power module and monitoring bypass module, you must use multi-meter measurement on the DC bus capacitor voltage is lower than 36Vdc, and use a multi-meter to measure the voltage between operating parts and the earth to ensure the voltage is lower than hazardous voltage, DC voltage is lower than 36Vdc, and AC maximum voltage is lower than 30Vac.
3. Only when UPS is in Maintenance Bypass Mode or UPS is completely powered off, the monitoring bypass module can be disassembled.
4. The power module can not be used for maintenance until 10 minutes after pulling out, and can be reinserted into the cabinet after 10 minutes.

6.2.2. Instruction for Maintaining Power module

Confirm the UPS is operating in Normal Mode and the bypass is working normally before pulling out the power module needed to be repaired.

1. Power off the power module. Press the “OFF” button on the power module panel for 3 seconds, the power module quits from the system.
2. Ensure the remaining power module will not be overloaded when one power module power off. If there is a risk of overload, please manually transfer the UPS system to bypass mode (refer to Chapter 5. 2.2) before proceeding with the following operations.
3. Wait 10 minutes, remove the fixing screws on both sides of the front panel of the power module and pull it out of the cabinet.
4. After the repairing is done, push the power module into the cabinet (The push-in interval of each power module is more than 10s), turn the knob to the locked position, and tighten screws on both sides. The power module will automatically join the system.
5. If you manually switch the UPS system to bypass mode in Step 2, the power module will restore the UPS system to normal mode after starting the power module for 2 minutes. For details, see Section 5.2.3.

6.2.3. Monitoring Bypass Module for Cabinet

Confirm the UPS is operating in Normal mode and the bypass is working normally:

1. Transfer the system to bypass mode through the LCD control panel, the UPS switches to bypass supply.
2. Turn on the maintenance bypass breaker.
3. One by one to turn off the battery breaker, input breaker, bypass input breaker and output breaker. The load is powered through maintenance bypass.
4. Remove the fixing screws on both sides of the front panel of the monitoring module, unplug the LCD cable on the front panel of the monitoring module, and pull out the monitoring module to maintain it.
5. Remove the screws on both sides of the front panel of the bypass module and pull out the bypass module to maintain the bypass module.
6. After the completion of maintenance, insert power module and tighten the screws on both sides of the power module.
7. One by one to turn on the output breaker, bypass input breaker, input breaker and battery breaker.
8. After 2 minutes, the bypass indicator LED goes green, and the load is powered through maintenance bypass and static bypass.
9. Turn off the maintenance bypass breaker, the rectifier starts, after 60S, the system transfers to Normal mode.



Danger

When the model without external distribution breaker is in the maintenance bypass mode, the wiring terminal and connected copper bar or cable, and the maintenance bypass breaker connected copper bar or cable will be charged. Do not touch it to avoid danger.

6.2.4. Battery Maintenance

Generally, maintenance free batteries do not require manual maintenance when using. Operate according to certain requirements. The life of the battery can be prolonged. The factors that affect battery life are as follows: installation, temperature, charging and discharging current, charging voltage, discharge depth and long-term charging.

1. Installation. Batteries should be installed as clean as possible, in a cool, airy, dry place, avoiding exposure to direct sunlight or other radiant heat sources. When installing the battery, pay attention to the accuracy and quantity of the battery. The batteries with different specifications and batch numbers should not be mixed.
2. Temperature. Keep the temperature of the battery at about 25°C.
3. Charge discharge current. The optimum charging current of lead-acid battery is about 0.

1C, and the charging current must not be greater than 0.3C. Charging current is too large or too small, will affect the battery life. Discharge current is generally required at 0.05–0.3C.

4. Charging voltage. Because the UPS battery belongs to the standby mode, the battery will be discharged only when the power supply is abnormal or the battery will be charged in normal mode. To prolong the life of battery charger, UPS generally uses the constant voltage/current limiting control, after the battery is turned into floating state, each section of the floating voltage set to about 13.5V. If the charge voltage is too high, the battery will be overcharged; otherwise the battery will not be charged enough.
5. Discharge depth. The deeper the discharge depth is, the less cycle times to be, so the depth discharge should be avoided. UPS in the case of light load discharge or no-load discharge will cause deep discharge of the battery.
6. Regular maintenance. The battery should be checked regularly, such as observing its appearance and measuring the voltage of the battery. If the battery is not discharged for a long time, the activity will become worse, so the UPS also needs periodic discharge test to keep the battery active.
7. Check the battery regularly for leakage, deformation and so on.

7. Product Specification

7.1. Content

This chapter provides the specifications of the product, including environmental characteristics mechanical characteristics and electrical characteristics.

7.2. Applicable Standards

The UPS has been designed to conform to the following European and international standards provided in Table 7-1.

Table 7-1 Compliance with European and international standards

Item	Normative references
General safety requirements for UPS used in operator access areas	EN50091-1-1/IEC62040-1-1/AS 62040-1-1
Electromagnetic compatibility (EMC) requirements for UPS	EN50091-2/IEC62040-2/AS 62040-2 (C3)
Method of specifying the performance and test requirements of UPS	EN50091-3/IEC62040-3/AS 62040-3 (VFI SS 111)



Note

The above mentioned product standards incorporate relevant compliance clauses with generic IEC and EN standards for safety (IEC/EN/AS60950), electromagnetic emission and immunity (IEC/EN/ AS61000 series) and construction (IEC/EN/AS60146 series and 60950).

7.3. Environmental Characteristics

Table 7-2 Environmental characteristics

Item	Unit	Requirement
Acoustic noise level at 1 meter	dB	75dB @ 100% load, 70dB @ 45% load
Altitude of operation	m	≤1000. Within 1000-2000m, 1% power derating for every 100m rise
Relative humidity	%RH	0-95, non-condensing
Operating temperature	°C	0-40, Battery life is halved for every 10 °C increase above 20 °C
UPS storage temperature	°C	-40-70
Recommended battery storage temperature	°C	-20–30 (20°C is the best battery storage temperature)

7.4. Mechanical Characteristic

The main physical parameters of the cabinet (including bypass module) are provided in Table 7-3.

Table 7-3 Mechanical characteristics for cabinet

Model	Unit	Specification
Cabinet type	N/A	600kVA cabinet (including bypass module)
Mechanical dimension (W*D*H)	mm	800*1100*2000
Weight	kg	405
color	N/A	Black
Protection level (IEC60529)	N/A	IP20

The main physical parameters of the cabinet are provided in Table 7-4.

Table 7-4 Mechanical characteristics for power module

Model	Unit	Specification
Mechanical dimension (W*D*H)	mm	550*750*85
Weight	kg	36

7.5. Electrical Characteristics

7.5.1. Electrical Characteristics (Input Rectifier)

The main electrical features of the rectifier are provided in Table 7-5.

Table 7-5 Rectifier AC input (utility)

Item	Unit	Specification
Grid system	\	3 Phases + Neutral + Ground
Rated AC input voltage	Vac	380/400/415 (three-phase and sharing neutral with the bypass input)
Rated frequency	Vac	50/60Hz
Input voltage range	Vac	323-478Vac (line-line), full load 138V-323Vac (line-line), load decrease linearly from 100% to 30%
Input frequency range	Hz	40-70
Input power factor	kW/kVA, full load	>0.99
THDI	THDi%	<3% (full linear load)

7.5.2. Electrical Characteristics (Intermediate DC Link)

Table 7-6 Battery

Items	Unit	Specification
Battery bus voltage	Vdc	Rated: $\pm 240V$
Quantity of lead-acid cells	Nominal	40=[1 battery (12V)], 240=[1 battery (2V)]
Float charge voltage	V/cell (VRLA)	2.25V/cell (selectable from 2.2V/cell–2.35V/cell) Constant current and constant voltage charge mode
Temperature compensation	mV/°C/cl	-3.0 (selectable: 0–5.0)
Ripple voltage	%	≤ 1
Ripple current	%	≤ 5
Equalized charge voltage	VRLA	2.4V/cell (selectable from: 2.30V/cell–2.45V/cell) Constant current and constant voltage charge mode
Final discharging voltage	V/cell (VRLA)	1.65V/cell (selectable from: 1.60V/cell–1.750V/cell) @0.6C discharge current 1.75V/cell (selectable from: 1.65V/cell–1.8V/cell) @0.15C discharge current (EOD voltage changes linearly within the set range according to discharge current)
Battery charge	V/cell	2.4V/cell (selectable from: 2.3V/cell–2.45V/cell) Constant current and constant voltage charge mode
Battery charging power max current	kW	30%* UPS capacity (selectable from: 1–30%* UPS capacity)



Note

The default number of batteries is 40, please see the UPS battery voltage identification on the nameplate before installation, if the battery number is set to 32–44 pcs in the actual, please change the settings, and then connect the battery, otherwise the risk of damage. Please contact the manufacturer's customer service phone about the operation steps.

7.5.3. Electrical Characteristics (Inverter Output)

Table 7-7 Inverter output (to critical load)

Item	Unit	Specification
Rated capacity	kVA	60–600
Rated AC voltage	Vac	380/400/415 (three-phase four-wire, sharing neutral with the bypass)
Rated frequency	Hz	50/60
Frequency regulation	Hz	50/60Hz $\pm 0.01\%$

Item	Unit	Specification
Rated capacity	kVA	60-600
Voltage precision	%	±1.0 (0-100% linear load)
Overload	%	110%, 1 hour 125%, 10min 150%, 1min >150%, 200ms
Synchronized range	Hz	Settable, ±0.5Hz-±5Hz, default ±3Hz
Synchronized slew rate	Hz	Settable, 0.5Hz/s-3Hz/s, default 0.5Hz/s
Output power factor	PF	0.9
Transient response		<5% for step load (20% - 80% -20%)
Transient recovery		< 20ms for step load (0% - 100% -0%)
Output voltage THDu		<1% from 0% to 100% linear load <5% full non-linear load according to IEC/EN62040-3

7.5.4. Electrical Characteristics (Bypass Utility Input)

Table 7-8 Bypass utility input

Item	Unit	Specification
Rated capacity	kVA	600
Rated AC voltage	Vac	380/400/415 (three-phase four-wire and sharing neutral with the bypass, provide a neutral reference for the output)
Rated current	A	92-920 (see Table)
Overload	%	110%, long term operation 110%-125%, 10min 125%-150%, 1min >150%, 200ms
Current rating of neutral cable	A	1.7×In
Rated frequency	Hz	50/60
Switch time (between bypass and inverter)	ms	Synchronous transfer: 0ms
Bypass voltage range	%	Settable: Up limited: +10, +15, +20, default is +15 Down limited:-10, -15, 30, -40, default is -20
Bypass frequency range	Hz	Settable, ±1, ±3, ±5

7.6. Efficiency

Table 7-9 Efficiency and heat dissipation

Item	Unit	Specification
Overall efficiency		
Normal mode (dual conversion)	%	>97
ECO mode	%	>99
Battery discharging efficiency (DC/AC) (at nominal voltage 480Vdc and full-rated linear load)		
Battery mode	%	>96

7.7. Display and Interface

The system display and interface are provided in Table 7-10:

Table 7-10 System display and interface

Display	LED + LCD +Touch screen
Interface	Standard: CAN, RS485, USB, dry contact Optional: RS485 expansion card, SNMP card, AS400 card



66001-01193

Manual information may be subject to change without prior notice.

202605 (V1.4)