

A solid blue square graphic located on the left side of the page.

XD3-6KTL-PRO

Hybrid Inverter

Quick Installation Guide



Contents

- 1 Safety precautions 1**
- 2 Product overview 2**
 - 2.1 Product structure2
- 3 Installation 3**
 - 3.1 Unpacking inspection3
 - 3.2 Preparation before installation3
 - 3.2.1 Environment requirements3
 - 3.2.2 Installation space3
 - 3.2.3 Installation orientation4
 - 3.3 Mechanical installation4
 - 3.4 Electrical installation6
 - 3.4.1 Cable specifications6
 - 3.4.2 Electrical connections7
 - 3.4.3 AC wiring8
 - 3.4.4 PV wiring9
 - 3.4.5 BAT wiring10
 - 3.4.6 Communication and signal connections11
 - 3.4.7 Signal terminal connections13
- 4 Operation and maintenance 15**
 - 4.1 Pre-Operation inspection15
 - 4.2 Inverter on-grid operation15
 - 4.3 Inverter LED indicators15
 - 4.4 RS485 cable (optional) pin definitions16
 - 4.5 Maintenance16

1 Safety precautions



- The inverter must be installed by qualified professionals.
- Do not store, place, or install the inverter on or near flammable or explosive materials.
- Select an installation site away from electronic equipment with strong electromagnetic interference.
- Do not install the inverter in locations easily accessible to children or unauthorized personnel.
- Select compatible batteries and correctly configure the battery type. Incorrect battery configuration will prevent the system from operating.
- If the battery is fully discharged, strictly follow the corresponding battery user manual for charging and maintenance.
- Before installation or electrical connection, remove rings, bracelets, and other metal accessories from your hands to avoid accidental contact with live parts and the risk of electric shock.
- Ensure the PV string input voltage does not exceed the maximum input voltage of the inverter. Failure to do so may cause damage to the inverter.
- The inverter is not suitable for solar modules whose positive or negative pole is grounded.
- Ensure that the inverter PE is reliably grounded. If the PE is not grounded or the grounding is unreliable, the inverter will not operate properly.
- Ensure that the inverter is securely installed and the electrical connections are reliable.

2 Product overview

2.1 Product structure

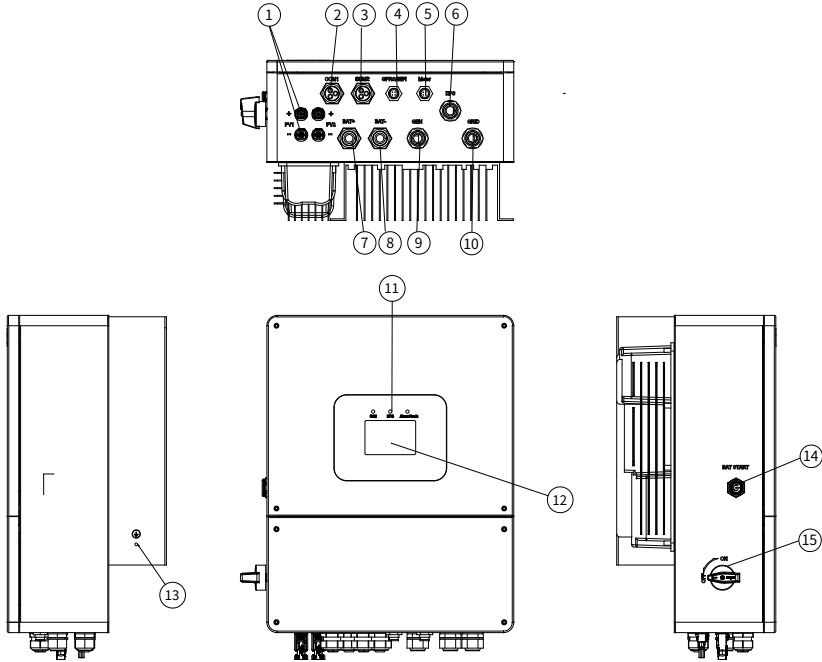

No.	Definition	No.	Definition
1	PV input terminal	2	CT/DRY/DRM/other port
3	Battery Management System (BMS)/parallel communication cable port	4	Stick logger
5	Meter RS485 communication port	6	EPS load port
7	Battery positive (+) port	8	Battery negative (-) port
9	Diesel generator port	10	Grid port
11	LED indicator	12	LCD display
13	PE grounding point	14	Battery power-on button
15	PV DC switch		

3 Installation

3.1 Unpacking inspection

Before unpacking, check whether the package is in good condition and its product information is the same as on the nameplate. If you have any questions, contact the supplier promptly.

No.	Name	Quantity
1	Hybrid inverter	1
2	DC connector (pair)	2
3	Documentation (set)	1
4	Stainless steel expansion bolt, M6 × 50	3
5	M6 SEMS bolt	3
6	M4 SEMS screw	1
7	M6 nut	3
8	External CT	1
9	BMS communication cable and parallel communication cable	2
10	Stick logger	1

3.2 Preparation before installation

3.2.1 Environment requirements

The installation ambient temperature shall be -30°C to $+60^{\circ}\text{C}$.

3.2.2 Installation space

Select an installation site that meets the following requirements:

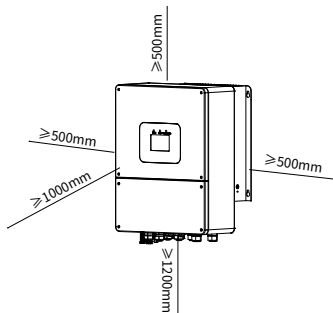

Figure 3-1 Inverter installation clearances

3.2.3 Installation orientation

Ensure that the installation surface is perpendicular to the horizontal line, as shown in Figure 3-2.

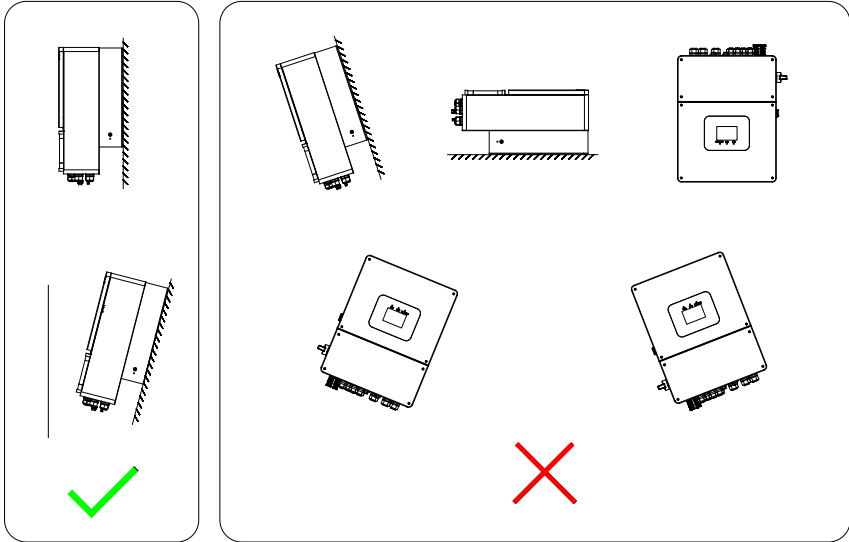

Figure 3-2 Inverter installation orientations

3.3 Mechanical installation

The mounting hole layout is shown in the figure below:

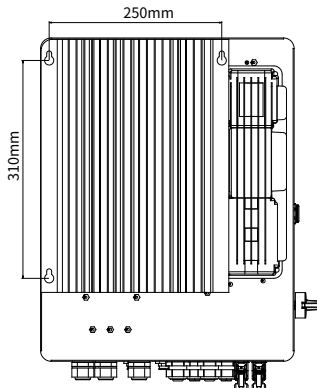

Figure 3-3 Mounting hole layout

The inverter features a bracket-free wall-mounting design. Follow these steps to install the inverter:

Step 1 Mark the hole positions on the wall according to the installation dimensions, and then drill the holes.

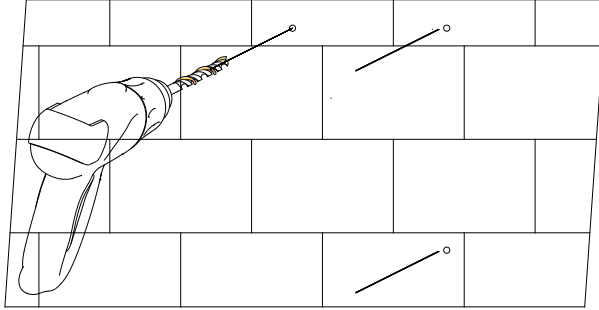

Figure 3-4 Drilling mounting holes

Step 2 Use a rubber mallet to tap the expansion bolts into the holes, then tighten them against the wall to $13 \text{ N} \cdot \text{m}$. M6 \times 50 stainless steel expansion bolts are recommended.

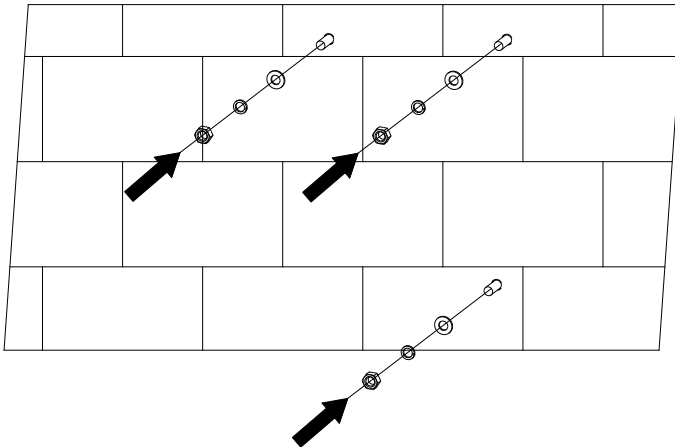

Figure 3-5 Tightening the expansion bolts

Step 3 Align the heat sink slots with the expansion bolts and engage them. Slide the inverter downward until it is securely seated, ensuring that the heat sink groove fits closely against the wall. Then tighten the nuts on the expansion bolts.

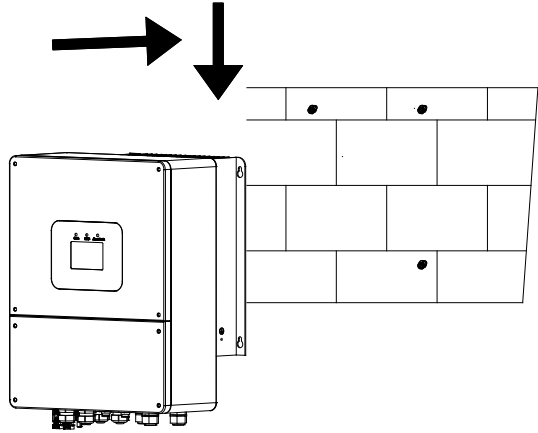

Figure 3-6 Engaging the heat sink slots with the expansion bolts

3.4 Electrical installation

3.4.1 Cable specifications

To ensure that the AC/DC connectors or terminals are compatible with the inverter, the cables used for the corresponding inverter model must meet the following specifications:

Table 3-1 Cable specifications

Inverter model	PV DC side	AC side
	Recommended minimum cable size (length ≤ 50m)	Recommended minimum cable size (length ≤ 50m)
XD3-6KTL-PRO	11AWG	9AWG

3.4.2 Electrical connections

Note: The following wiring method applies to regions such as Australia, New Zealand, and South Africa.

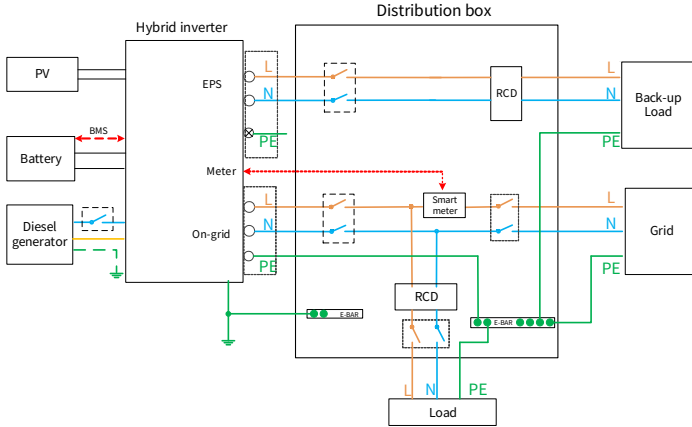

Figure 3-7 Hybrid inverter electrical wiring

Note: The following wiring method applies to regions other than Australia, New Zealand, and South Africa.

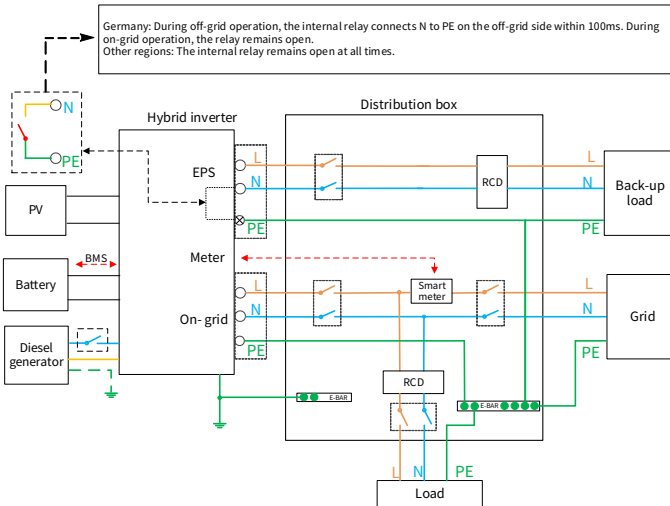
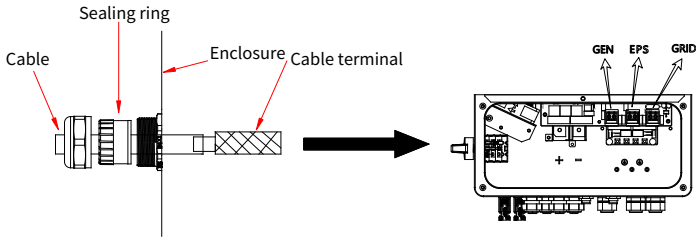

Figure 3-8 Hybrid inverter electrical wiring

3.4.3 AC wiring

The AC side of the single-phase hybrid inverter includes the GEN port for the diesel generator, the off-grid EPS port, and the on-grid GRID port. The wiring configuration is identical for all three ports. Follow the steps below to complete the electrical connections.

Step 1 Pass the cable through the rubber nut, sealing ring, and threaded sleeve in sequence.



Step 2 Connect the prepared AC cables to the GEN, EPS, and GRID ports on the inverter respectively.

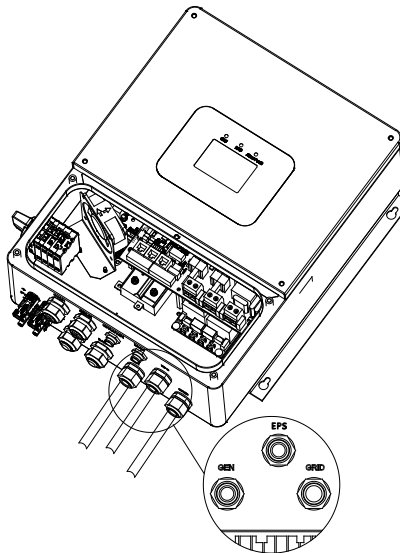

Step 3 Connect the L, N, and PE wires of the GEN, EPS, and GRID cables to the corresponding L, N, and PE pins on the inverter AC terminals, and tighten the screws.

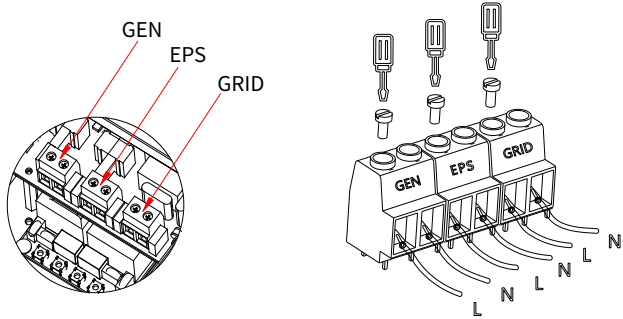

Note:

- If the inverter is used solely for on-grid operation, connect the grid to the inverter's GRID port.
- Do not directly connect the GEN, EPS, and GRID ports together, as this will damage the inverter.
- Do not connect the grid or a generator to the EPS port, as this will damage the inverter.
- The power cables for these three ports shall have a minimum cross-sectional area of 6.6mm² (9 AWG or larger).

3.4.4 PV wiring

Step 1 Check the polarity of the PV string cables and ensure that the voltage of each string is within the allowable range of the inverter.

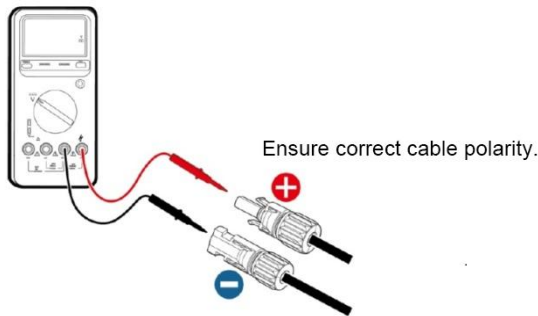

Step 2 Insert the positive (+) PV string connector into the PV+ input terminal and the negative (-) PV string connector into the PV- input terminal until both connectors are fully seated.

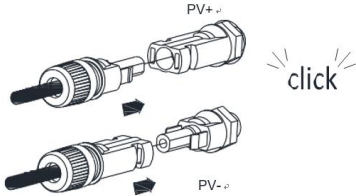

3.4.5 BAT wiring

To install the battery power cables, proceed as follows:

Step 1 Pass the positive (red) battery cable through the rubber nut, sealing ring, and threaded sleeve at the BAT+ opening in sequence. Pass the negative (black) battery cable through the rubber nut, sealing ring, and threaded sleeve at the BAT- opening in sequence.

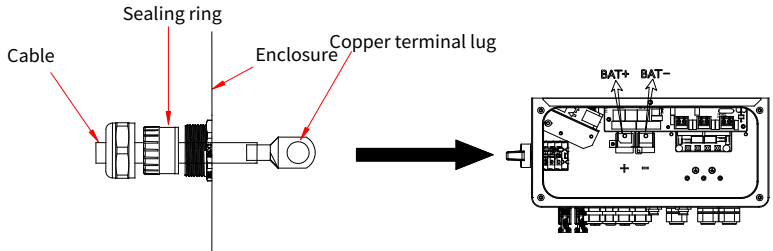

Step 2 Crimp the corresponding ring terminals onto the battery cables.

Step 3 Connect the positive terminal of the battery to the positive (+) battery terminal of the inverter using the red cable, and connect the negative terminal of the battery to the negative (-) battery terminal of the inverter using the black cable. Then tighten the screws.

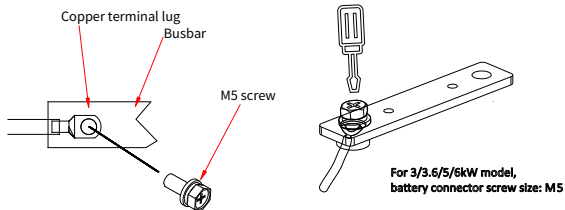

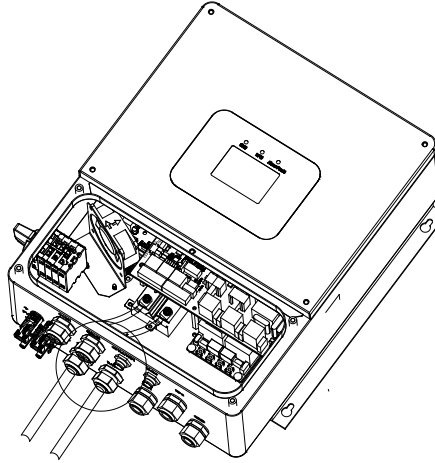
**Note:**

- A DC switch is required between the battery and the inverter.
- Each power cable between the battery and the inverter must be no longer than 1.5m, and have a minimum cross-sectional area of 33.6mm² (2 AWG).

3.4.6 Communication and signal connections

When using lithium batteries, the BMS must be connected. Proceed as follows to connect the BMS port:

Step 1 Unscrew the rubber nut of the COM2 opening on the inverter.

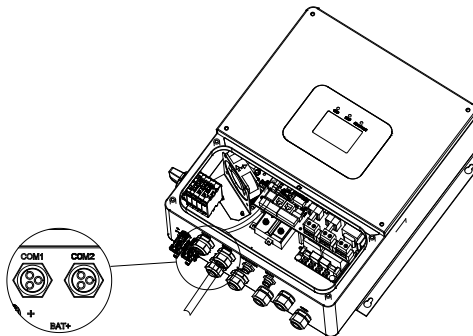

Step 2 Pass the BMS communication cable sequentially through the rubber nut, sealing ring, and threaded sleeve of the COM2 opening.

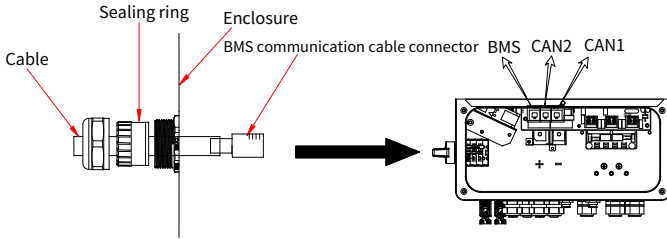

Step 3 Insert the BMS communication cable connector into the BMS port on the inverter.

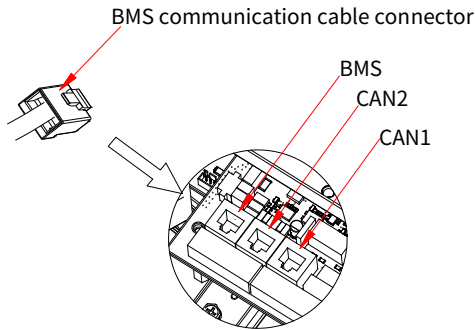

Step 4 Tighten the rubber nut back onto the COM2 opening.

Table 3-2 BMS communication cable and RJ45 pin definitions

Port	BMS communication cable
Pin1	485_L
Pin2	485_H
Pin3	GND
Pin4	CAN_H
Pin5	CAN_L
Pin6	GND
Pin7	485_H
Pin8	485_L

The diagram shows an RJ45 connector and a BMS communication cable connector. The RJ45 connector is labeled with pins 1 through 8. The BMS communication cable connector is labeled with Pin 1.

Note: For lead-acid batteries, skip the BMS communication cable connection and proceed to lead-acid battery wiring.

To monitor the ambient temperature of a lead-acid battery, install the NTC temperature sensor as follows:

- Step 1 Unscrew the rubber nut of the COM1 opening on the inverter.
- Step 2 Pass the NTC cable sequentially through the rubber nut, sealing ring, and threaded sleeve.
- Step 3 Pass the NTC cable through the COM1 rubber nut opening and connect it to Pin 5 and Pin 7 of CN13 on the circuit board (refer to section 3.4.7 Signal terminal connections).
- Step 4 Tighten the rubber nut onto the COM1 opening.

Note: The sensor probe is used to monitor the ambient temperature of the lead-acid batteries. Its cable length must be less than 1.5m. If a lithium battery is used, the temperature sensor is not required.

3.4.7 Signal terminal connections

Follow these steps to connect the CT, DRY, DRM, and other signal terminals:

- Step 1 Unscrew the rubber nut of the COM1 opening on the inverter.
- Step 2 Pass the signal cable sequentially through the rubber nut, sealing ring, and threaded sleeve of the COM1 opening.
- Step 3 Connect the signal cable to the CN13 and CN31 terminals on the inverter.
- Step 4 Tighten the rubber nut onto the COM1 opening.

The locations of the two 10-pin signal terminals, CN13 and CN31, are shown in the figure below.

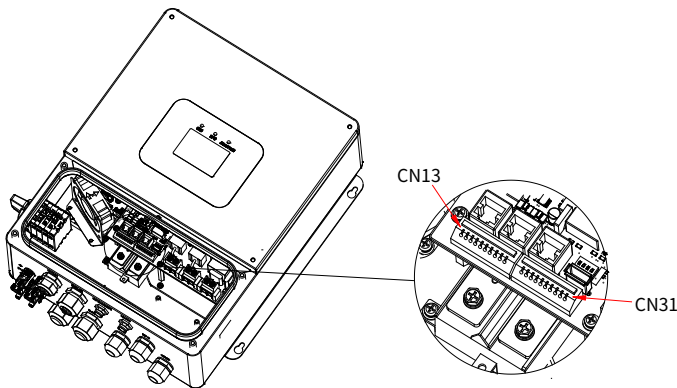

The pin definitions for signal terminals CN13 and CN31 are as follows:

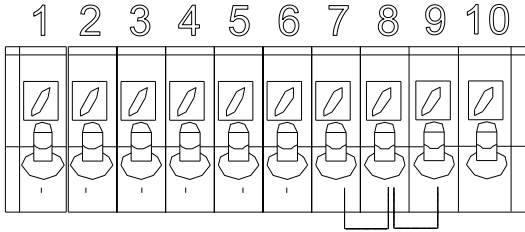

Table 3-3 CN13 pin definitions

Pin	Definition	Description
Pin1	CT1_G	CT1 signal ground
Pin2	CT1	CT1 signal
Pin3	CT2_G	CT2 signal ground
Pin4	CT2	CT2 signal
Pin5	BAT_T	Lead-acid battery temperature signal
Pin6	RSD	Rapid shutdown signal
Pin7	GNDS	Ground for external signals
Pin8	DRY1	Dry contact output, normally closed (NC)
Pin9	DRY2	Dry contact output, common (COM)
Pin10	DRY3	Dry contact output, normally open (NO)

Table 3-4 CN31 pin definitions

Pin	Definition	Description
Pin1	COM	DRM function
Pin2	REF	
Pin3	DRM4/8	
Pin4	DRM3/7	
Pin5	DRM2/6	
Pin6	DRM1/5	
Pin7	GNDS	Ground for external signals
Pin8	ALM_IN	Alarm input signal
Pin9	OFF	Emergency shutdown signal (active with 12V power supply)
Pin10	12V	External +12V power supply

4 Operation and maintenance

4.1 Pre-Operation inspection

Check the following items before operating the inverter:

- The PV string input voltage is within the allowable input voltage range of the inverter.
- The voltage at the AC terminal is within the normal grid voltage range.
- The battery wiring is correct and the battery voltage is normal.
- The inverter is properly grounded.
- All switches are in the OFF position.
- Electrical safety signs at the installation site are clear.
- The communication module is connected properly.

4.2 Inverter on-grid operation

Strictly follow the steps below to power on the inverter for on-grid operation:

Step 1 Turn on the PV switch.

Step 2 Turn on the switch between the grid and the inverter.

Step 3 Turn on the switch between the battery and the hybrid inverter to activate the battery.

Step 4 To configure inverter parameters, refer to the user manual.

To shut down the inverter, refer to section 4.5 Maintenance.

4.3 Inverter LED indicators

The LED indicator status descriptions are as follows:

LED status	Definition
Red (steady on)	Fault
Green (steady on)	Normal operation
Green (flashing)	Grid-connection countdown
Yellow (steady on)	Off-grid
Yellow + green (flashing)	Firmware upgrade

4.4 RS485 cable (optional) pin definitions



Table 4-1 RS485 pin definitions

Pin	Definition
1 (red)	+5VDC
2 (orange)	A (RS485+)
3 (brown)	B (RS485-)
4 (black)	GND

4.5 Maintenance

For power-off maintenance, inspection, or troubleshooting, strictly follow the steps below to shut down the inverter:

Step 1 Turn off the switch between the inverter and the grid.

Step 2 Turn off the PV switch of the inverter.

Step 3 Turn off the battery switch of the inverter.

Step 4 Verify that the inverter is completely powered off before performing any maintenance.

Step 5 For further assistance, contact our customer service or your local dealer.



INVT Solar Technology (Shenzhen) Co., Ltd.

Quality Certificate



Inspector: _____

This product has been inspected by the Quality Control (QC) and Quality Assurance (QA) departments. Its performance parameters conform to the standards specified in the user manual. It is hereby approved for delivery.



Your Trusted Industry Automation and Energy Efficiency Solutions Provider



INVT Solar Technology (Shenzhen) Co., Ltd.

Address: 6th Floor, Building A, INVT Guangming Technology Building,
Songbai Road, Matian, Guangming District, Shenzhen, China

E-mail: solar-service@invt.com.cn Website: www.invt-solar.com



Mobile website



E-manual



6 8 0 0 1 - 0 1 6 5 3