

IMS20B-A Series Medium-Power Air-Cooled Servo Motor (Frame Sizes 200 and 263)

User Manual

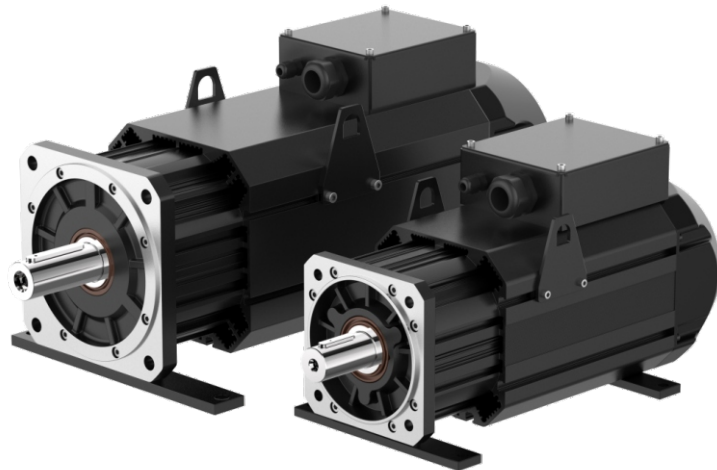

Preface

Overview

Thank you for purchasing the IMS20B-A series medium-power air-cooled servo motors with frame sizes 200 and 263.

IMS20B-A series medium-power air-cooled servo motor is a newly developed motor product by our company, covering a power range of 6.3kW–90kW, with frame sizes of 200 and 263. It offers various inertia configurations and speed ranges, and different types of encoders can be configured according to customer requirements.

This product is suitable for the general automation industry, working with servo drives to achieve fast and precise control of position, speed, and torque.

This manual provides product information, specifications, dimensions, and other relevant details about the motor. If you have any questions, please contact our technical support.

Readers

Personnel with electrical professional knowledge (such as qualified electrical engineers or personnel with equivalent knowledge).

Change history

The manual is subject to change irregularly without prior notice due to product version upgrades or other reasons.

No.	Change description	Version	Release date
1	First release.	V1.0	March 2026

Contents

1 Safety precautions	1
1.1 Safety declaration	1
1.2 Safety level definition	1
1.3 Personnel requirements	1
1.4 Safety guidelines	1
1.5 Warning symbols	3
2 Motor model selection	4
3 Common terms	9
3.1 Duty	9
3.2 Ingress protection (IP) rating	9
3.3 Rated parameters	10
4 Product overview	11
4.1 Product features	11
4.2 Model and nameplate	11
4.3 Product component (frame sizes 200 and 263)	12
5 General specifications	13
5.1 Mechanical characteristics	13
5.2 Derating characteristics	13
5.2.1 Derating due to altitude	13
5.2.2 Derating due to temperature	14
6 Medium-power air-cooled servo motor	15
6.1 Frame size 200	15
6.1.1 Motor parameters	15
6.1.2 Motor dimensions	17
6.1.3 External characteristic curve	18
6.2 Frame size 263	22
6.2.1 Motor parameters	22
6.2.2 Motor dimensions	24
6.2.3 External characteristic curve	25
7 Motor terminal and junction box	29
7.1.1 Encoder terminal	29
7.1.2 Terminal box component	29
7.1.3 Terminal box dimension	30
8 Installation instructions	32
8.1 Unpacking inspection	32
8.2 Mechanical installation	32
8.2.1 Preparing	32
8.2.2 Installation method	33
8.3 Check after installation	34
9 Common faults	36
10 Certification categories and standards	37
10.1 CE certification	37
10.2 China energy efficiency label	37



1 Safety precautions

1.1 Safety declaration

Read this manual carefully and follow all safety precautions before moving, installing, wiring, operating and servicing the product. Otherwise, equipment damage or physical injury or death may be caused.

We shall not be liable or responsible for any injury or equipment damage caused due to failure to follow the safety precautions.



1.2 Safety level definition

Safety level	Description
	Severe personal injury or even death can result if related requirements are not followed.
	Personal injury or equipment damage can result if related requirements are not followed.



1.3 Personnel requirements



Trained and qualified professionals: People operating the equipment must have received professional electrical and safety training and obtained the certificates, and must be familiar with all steps and requirements of equipment installing, commissioning, running and maintaining and capable to prevent any emergencies according to experiences.



1.4 Safety guidelines

Unpacking inspection	
	<ul style="list-style-type: none"> • Ensure that the packaging of the servo motor product is intact, with no damage, rust, moisture, dampness, or deformation. • Please handle with care when unpacking and retrieving the motor to avoid any collisions and damage to the motor. • After opening the packaging box, confirm that the machine is undamaged or unbroken, that all components are complete, and that the nameplate and label on the product body match the ordered model.
Delivery	
	<ul style="list-style-type: none"> • Ensure that the motor is securely installed during transportation to prevent accidental falls. • Do not transport motor products with items that could cause damage. • Before handling large motor products, check the fixed lifting position of the motor and ensure the safety of the lifting equipment during the handling process. • Do not move the motor by pulling the cables or the shaft.

Installation	
	<ul style="list-style-type: none"> • Read this manual carefully before installation and strictly follow all safety precautions. • Ensure that the mechanical strength of the installation location is sufficient to support the weight of the equipment. • Please check for any abnormalities in the motor mounting holes before installation. • Do not disassemble any components or parts of the motor. If any modifications are needed, please contact a professional. • When performing installation work, cover the product to prevent metal shavings and foreign objects from entering the motor, which could affect its safety.

Wiring	
	<ul style="list-style-type: none"> • Ensure that the overcurrent protector, leakage current protector and emergency device are installed. After wiring is completed, their effectiveness must be verified. • Ensure that the AC power supply voltage matches the rated voltage of the servo motor. • Do not place the power cables and encoder cables in a strong magnetic field environment. • Ensure that the equipment and products have good grounding.
	<ul style="list-style-type: none"> • Before wiring, check the integrity of the power cables. Do not use power cables that are damaged or exposed. • Ensure that the drive is correctly wired to the motor.

Check before power-on	
	<ul style="list-style-type: none"> • Ensure that the product wiring connections are correct. • Ensure that there are no personnel lingering around the drive, motor, and related equipment. • Ensure that the key is securely fixed. If there is no coupling to secure the key, remove the key to prevent it from flying out during motor operation.
	<ul style="list-style-type: none"> • Ensure that the emergency stop switch is properly connected to the drive.



Running	
	<ul style="list-style-type: none"> • De-couple the motor load and run the motor independently during the trial operation to avoid accidents. • Do not touch conductive parts directly while in operation. • Do not connect any external cables (especially those related to electricity) to the enclosure or short connect the external cables. • If you need to rewire the motor, disconnect the power and wait for 15 minutes before proceeding.
	<ul style="list-style-type: none"> • Set the corresponding parameters before operation, otherwise the motor may run abnormally or beyond the expectation because of the load. • The motor housing heat sink can reach high temperatures during operation. Do not touch the motor housing heat sink.

Maintenance and repair	
	<ul style="list-style-type: none"> • Non-professional personnel are strictly prohibited from installing, wiring, maintaining, inspecting, or replacing components of the equipment. • For maintenance, repair, and component replacement of the motor, please contact a qualified technician. • Maintenance of the equipment is strictly prohibited while it is powered on.

Scrapping	
	<ul style="list-style-type: none"> • The components inside the motor contain heavy metals. Please follow the relevant national regulations and standards for the disposal of equipment and products. After disposal, the motor must be treated as industrial waste.

1.5 Warning symbols

To ensure safe operation, please strictly adhere to the safety labels affixed to the equipment. Do not damage or remove the safety labels. The warning symbols are as follows:

Warning symbols	Description
	<ul style="list-style-type: none"> • Caution: high temperature on the motor surface!
	<ul style="list-style-type: none"> • Caution: risk of electric shock!
	<ul style="list-style-type: none"> • Do not strike the motor shaft extension!

2 Motor model selection

Frame size	Output power (kW)	Motor model	Brake	Encoder	Compatible drive model	Compatible VFD model
200	6.3kW	IMS20B-20M63C15C-4-R7F-A	-	Resolver	SV-DA200-5R5-4-**	MH860C-S018TF7
	6.3kW	IMS20B-20M63C15C-4-P9F-A	-	23-bit multi-turn optical encoder		
	6.3kW	IMS20B-20M63C15C-4-P94F-A	Electromagnetic brake	23-bit multi-turn optical encoder		
	7.1kW	IMS20B-20M71C17C-4-R7F-A	-	Resolver		
	7.1kW	IMS20B-20M71C17C-4-P9F-A	-	23-bit multi-turn optical encoder		
	7.1kW	IMS20B-20M71C17C-4-P94F-A	Electromagnetic brake	23-bit multi-turn optical encoder		
	8kW	IMS20B-20M80C20C-4-R7F-A	-	Resolver		
	8kW	IMS20B-20M80C20C-4-P9F-A	-	23-bit multi-turn optical encoder		
	8kW	IMS20B-20M80C20C-4-P94F-A	Electromagnetic brake	23-bit multi-turn optical encoder		
	9.4kW	IMS20B-20M94C15C-4-R7F-A	-	Resolver		
	9.4kW	IMS20B-20M94C15C-4-P9F-A	-	23-bit multi-turn optical encoder		
	9.4kW	IMS20B-20M94C15C-4-P94F-A	Electromagnetic brake	23-bit multi-turn optical encoder		
	10.7kW	IMS20B-20M11D17C-4-R7F-A	-	Resolver		
	10.7kW	IMS20B-20M11D17C-4-P9F-A	-	23-bit multi-turn optical encoder		
	10.7kW	IMS20B-20M11D17C-4-P94F-A	Electromagnetic brake	23-bit multi-turn optical encoder		
	12.1kW	IMS20B-20M12D20C-4-R7F-A	-	Resolver		
	12.1kW	IMS20B-20M12D20C-4-P9F-A	-	23-bit multi-turn optical encoder		
	12.1kW	IMS20B-20M12D20C-4-P94F-A	Electromagnetic brake	23-bit multi-turn optical encoder		
	12.6kW	IMS20B-20M13D15C-4-R7F-A	-	Resolver		
	12.6kW	IMS20B-20M13D15C-4-P9F-A	-	23-bit multi-turn optical encoder		
12.6kW	IMS20B-20M13D15C-4-P94F-A	Electromagnetic brake	23-bit multi-turn optical encoder			
14.2kW	IMS20B-20M14D17C-4-R7F-A	-	Resolver			
14.2kW	IMS20B-20M14D17C-4-P9F-A	-	23-bit multi-turn optical encoder			
14.2kW	IMS20B-20M14D17C-4-P94F-A	Electromagnetic brake	23-bit multi-turn optical encoder			

Frame size	Output power (kW)	Motor model	Brake	Encoder	Compatible drive model	Compatible VFD model		
200	16.8kW	IMS20B-20M17D20C-4-R7F-A	-	Resolver	SV-DA200-011-4-**	MH860C-S032TF7		
	16.8kW	IMS20B-20M17D20C-4-P9F-A	-	23-bit multi-turn optical encoder				
	16.8kW	IMS20B-20M17D20C-4-P94F-A	Electromagnetic brake	23-bit multi-turn optical encoder				
	15.7kW	IMS20B-20M16D15C-4-R7F-A	-	Resolver				
	15.7kW	IMS20B-20M16D15C-4-P9F-A	-	23-bit multi-turn optical encoder				
	15.7kW	IMS20B-20M16D15C-4-P94F-A	Electromagnetic brake	23-bit multi-turn optical encoder				
	17.8kW	IMS20B-20M18D17C-4-R7F-A	-	Resolver				
	17.8kW	IMS20B-20M18D17C-4-P9F-A	-	23-bit multi-turn optical encoder				
	17.8kW	IMS20B-20M18D17C-4-P94F-A	Electromagnetic brake	23-bit multi-turn optical encoder				
	20kW	IMS20B-20M20D20C-4-R7F-A	-	Resolver			SV-DA200-015-4-**	MH860C-S045TF7
	20kW	IMS20B-20M20D20C-4-P9F-A	-	23-bit multi-turn optical encoder				
	20kW	IMS20B-20M20D20C-4-P94F-A	Electromagnetic brake	23-bit multi-turn optical encoder				
	18.9kW	IMS20B-20M19D15C-4-R7F-A	-	Resolver				
	18.9kW	IMS20B-20M19D15C-4-P9F-A	-	23-bit multi-turn optical encoder				
	18.9kW	IMS20B-20M19D15C-4-P94F-A	Electromagnetic brake	23-bit multi-turn optical encoder				
	21.4kW	IMS20B-20M21D17C-4-R7F-A	-	Resolver	SV-DA200-015-4-**	MH860C-S045TF7		
	21.4kW	IMS20B-20M21D17C-4-P9F-A	-	23-bit multi-turn optical encoder				
	21.4kW	IMS20B-20M21D17C-4-P94F-A	Electromagnetic brake	23-bit multi-turn optical encoder				
	24.1kW	IMS20B-20M24D20C-4-R7F-A	-	Resolver				
	24.1kW	IMS20B-20M24D20C-4-P9F-A	-	23-bit multi-turn optical encoder				
	24.1kW	IMS20B-20M24D20C-4-P94F-A	Electromagnetic brake	23-bit multi-turn optical encoder				
	22kW	IMS20B-20M22D15C-4-R7F-A	-	Resolver				
	22kW	IMS20B-20M22D15C-4-P9F-A	-	23-bit multi-turn optical encoder				
	22kW	IMS20B-20M22D15C-4-P94F-A	Electromagnetic brake	23-bit multi-turn optical encoder				
24.9kW	IMS20B-20M25D17C-4-R7F-A	-	Resolver					
24.9kW	IMS20B-20M25D17C-4-P9F-A	-	23-bit multi-turn optical encoder					
24.9kW	IMS20B-20M25D17C-4-P94F-A	Electromagnetic brake	23-bit multi-turn optical encoder					

Frame size	Output power (kW)	Motor model	Brake	Encoder	Compatible drive model	Compatible VFD model
200	27.4kW	IMS20B-20M27D20C-4-R7F-A	-	Resolver	SV-DA200-015-4-**	MH860C-S060TF7
	27.4kW	IMS20B-20M27D20C-4-P9F-A	-	23-bit multi-turn optical encoder		
	27.4kW	IMS20B-20M27D20C-4-P94F-A	Electromagnetic brake	23-bit multi-turn optical encoder		
	25.1kW	IMS20B-20M25D15C-4-R7F-A	-	Resolver		
	25.1kW	IMS20B-20M25D15C-4-P9F-A	-	23-bit multi-turn optical encoder		
	28.5kW	IMS20B-20M29D17C-4-R7F-A	-	Resolver		
	28.5kW	IMS20B-20M29D17C-4-P9F-A	-	23-bit multi-turn optical encoder		
	31.6kW	IMS20B-20M32D20C-4-R7F-A	-	Resolver	SV-DA200-022-4-**	MH860C-S075TF7
	31.6kW	IMS20B-20M32D20C-4-P9F-A	-	23-bit multi-turn optical encoder		
	28.3kW	IMS20B-20M28D15C-4-R7F-A	-	Resolver		
	28.3kW	IMS20B-20M28D15C-4-P9F-A	-	23-bit multi-turn optical encoder		
	32kW	IMS20B-20M32D17C-4-R7F-A	-	Resolver		
	32kW	IMS20B-20M32D17C-4-P9F-A	-	23-bit multi-turn optical encoder		
	35.6kW	IMS20B-20M36D20C-4-R7F-A	-	Resolver		
	35.6kW	IMS20B-20M36D20C-4-P9F-A	-	23-bit multi-turn optical encoder		
	31kW	IMS20B-20M31D15C-4-R7F-A	-	Resolver		
	31kW	IMS20B-20M31D15C-4-P9F-A	-	23-bit multi-turn optical encoder		
	36kW	IMS20B-20M36D17C-4-R7F-A	-	Resolver		
	36kW	IMS20B-20M36D17C-4-P9F-A	-	23-bit multi-turn optical encoder		
	40kW	IMS20B-20M40D20C-4-R7F-A	-	Resolver		
40kW	IMS20B-20M40D20C-4-P9F-A	-	23-bit multi-turn optical encoder			
263	28kW	IMS20B-26M28D15C-4-R7F-A	-	Resolver	SV-DA200-015-4-**	MH860C-S060TF7
	28kW	IMS20B-26M28D15C-4-P9F-A	-	23-bit multi-turn optical encoder		
	28kW	IMS20B-26M28D15C-4-P94F-A	Electromagnetic brake	23-bit multi-turn optical encoder		
	32kW	IMS20B-26M32D17C-4-R7F-A	-	Resolver	SV-DA200-022-4-**	MH860C-S075TF7
	32kW	IMS20B-26M32D17C-4-P9F-A	-	23-bit multi-turn optical encoder		
	32kW	IMS20B-26M32D17C-4-P94F-A	Electromagnetic brake	23-bit multi-turn optical encoder		
	37kW	IMS20B-26M37D20C-4-R7F-A	-	Resolver		
	37kW	IMS20B-26M37D20C-4-P9F-A	-	23-bit multi-turn optical encoder		
	37kW	IMS20B-26M37D20C-4-P94F-A	Electromagnetic brake	23-bit multi-turn optical encoder		
	34.6kW	IMS20B-26M35D15C-4-R7F-A	-	Resolver		
	34.6kW	IMS20B-26M35D15C-4-P9F-A	-	23-bit multi-turn optical encoder		
	34.6kW	IMS20B-26M35D15C-4-P94F-A	Electromagnetic brake	23-bit multi-turn optical encoder		

Frame size	Output power (kW)	Motor model	Brake	Encoder	Compatible drive model	Compatible VFD model	
263	39kW	IMS20B-26M39D17C-4-R7F-A	-	Resolver	SV-DA200-037-4-**	MH860C-S075TF7	
	39kW	IMS20B-26M39D17C-4-P9F-A	-	23-bit multi-turn optical encoder			
	39kW	IMS20B-26M39D17C-4-P94F-A	Electromagnetic brake	23-bit multi-turn optical encoder			
	45kW	IMS20B-26M45D20C-4-R7F-A	-	Resolver			
	45kW	IMS20B-26M45D20C-4-P9F-A	-	23-bit multi-turn optical encoder			
	45kW	IMS20B-26M45D20C-4-P94F-A	Electromagnetic brake	23-bit multi-turn optical encoder			
	40.8kW	IMS20B-26M41D15C-4-R7F-A	-	Resolver			
	40.8kW	IMS20B-26M41D15C-4-P9F-A	-	23-bit multi-turn optical encoder			
	46kW	IMS20B-26M46D17C-4-R7F-A	-	Resolver			
	46kW	IMS20B-26M46D17C-4-P9F-A	-	23-bit multi-turn optical encoder			
	49.8kW	IMS20B-26M50D20C-4-R7F-A	-	Resolver			
	49.8kW	IMS20B-26M50D20C-4-P9F-A	-	23-bit multi-turn optical encoder			
	47kW	IMS20B-26M47D15C-4-R7F-A	-	Resolver			
	47kW	IMS20B-26M47D15C-4-P9F-A	-	23-bit multi-turn optical encoder			
	53kW	IMS20B-26M53D17C-4-R7F-A	-	Resolver			
	53kW	IMS20B-26M53D17C-4-P9F-A	-	23-bit multi-turn optical encoder			
	58kW	IMS20B-26M58D20C-4-R7F-A	-	Resolver		SV-DA200-045-4-**	MH860C-S115TF7
	58kW	IMS20B-26M58D20C-4-P9F-A	-	23-bit multi-turn optical encoder			
	53.4kW	IMS20B-26M53D15C-4-R7F-A	-	Resolver			
	53.4kW	IMS20B-26M53D15C-4-P9F-A	-	23-bit multi-turn optical encoder			
	60.5kW	IMS20B-26M61D17C-4-R7F-A	-	Resolver			
	60.5kW	IMS20B-26M61D17C-4-P9F-A	-	23-bit multi-turn optical encoder			
	65kW	IMS20B-26M65D20C-4-R7F-A	-	Resolver			
	65kW	IMS20B-26M65D20C-4-P9F-A	-	23-bit multi-turn optical encoder			
	60kW	IMS20B-26M60D15C-4-R7F-A	-	Resolver			
	60kW	IMS20B-26M60D15C-4-P9F-A	-	23-bit multi-turn optical encoder			
	67.6kW	IMS20B-26M68D17C-4-R7F-A	-	Resolver	SV-DA200-055-4-**		MH860C-S115TF7
	67.6kW	IMS20B-26M68D17C-4-P9F-A	-	23-bit multi-turn optical encoder			
	74kW	IMS20B-26M74D20C-4-R7F-A	-	Resolver			
	74kW	IMS20B-26M74D20C-4-P9F-A	-	23-bit multi-turn optical encoder			
66kW	IMS20B-26M66D15C-4-R7F-A	-	Resolver				
66kW	IMS20B-26M66D15C-4-P9F-A	-	23-bit multi-turn optical encoder				

Frame size	Output power (kW)	Motor model	Brake	Encoder	Compatible drive model	Compatible VFD model
263	75kW	IMS20B-26M75D17C-4-R7F-A	-	Resolver	SV-DA200-090-4-**	MH860C-S150TF7
	75kW	IMS20B-26M75D17C-4-P9F-A	-	23-bit multi-turn optical encoder		
	82kW	IMS20B-26M82D20C-4-R7F-A	-	Resolver		
	82kW	IMS20B-26M82D20C-4-P9F-A	-	23-bit multi-turn optical encoder		
	78kW	IMS20B-26M78D15C-4-R7F-A	-	Resolver		
	78kW	IMS20B-26M78D15C-4-P9F-A	-	23-bit multi-turn optical encoder		
	86kW	IMS20B-26M86D17C-4-R7F-A	-	Resolver		
	86kW	IMS20B-26M86D17C-4-P9F-A	-	23-bit multi-turn optical encoder		
	90kW	IMS20B-26M90D20C-4-R7F-A	-	Resolver		
	90kW	IMS20B-26M90D20C-4-P9F-A	-	23-bit multi-turn optical encoder		

3 Common terms

3.1 Duty

A description of a series of load conditions that the motor experiences, including starting, electrical braking, no-load, shutdown, power interruption, as well as their duration and sequence. The duty complies with GB755.

S1 duty: Continuous duty

Operate under a constant load until reaching thermal stability, as shown in the following figure.

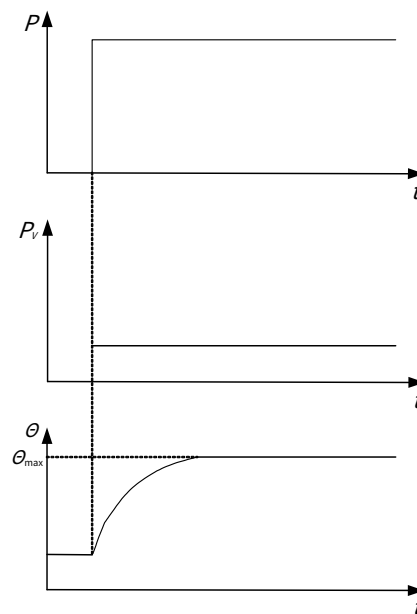

- P : Load
- P_v : Electrical losses
- θ : Temperature
- θ_{max} : Reach the maximum temperature
- t : Time

3.2 Ingress protection (IP) rating

The motor ingress protection rating is represented by a code that contains 2 letters and 2 digits. Including:

- IP: The code letters indicate the protection levels against the contact and ingress of solid objects and water.
- First digit: 0 to 6, indicates the level of protection provided by the enclosure against contact with persons and against ingress of solid objects inside the enclosure.
- Second digit: 0 to 8, indicates the level of protection against harmful effects due to the ingress of water into the enclosure.

IP rating	First digit	Meaning	Second digit	Meaning
IP	0	No protection at all	0	No protection at all.
	1	Protection against solid objects with a diameter greater than 50mm	1	Protection against vertical water drops.
	2	Protection against solid objects with a diameter greater than 12mm	2	Protection against vertical water drops at an angle of up to 15°.
	3	Protection against solid objects with a diameter greater than 2.5mm	3	Protection against sprayed water at an angle of up to 60°.
	4	Protection against solid objects with a diameter greater than 1mm	4	Protection against the splashing of water from any direction.
	5	Protection against the ingress of dust in such an amount that it will not interfere with the operation of the equipment	5	Protection against the water jets from any direction.
	6	Total protection against the ingress of any dust	6	Protection against powerful water jets from any direction.
	-	-	7	Protection against the ingress of water under defined conditions of pressure and time.
	-	-	8	Protection against long periods of immersion under the conditions specified by the manufacturer.

3.3 Rated parameters

Terms	Description
Rated power	The continuous operating power of the motor under specified conditions. Special duty type needs to be specified.
Rated speed	The rotational speed of the motor when it outputs the rated power at rated voltage and rated frequency.
Rated torque	The output torque of the motor when it reaches thermal steady state at rated power and rated speed.
Rated current	The current of the motor when it operates under rated conditions and reaches thermal steady state.

4 Product overview

4.1 Product features

- Comprehensive motor model: Involves 200 and 263 frame size motors, with a power range of 6.3kW to 90kW.
- Excellent motor performance: The motor has strong overload capacity.
- High control precision: The motor includes a 12-bit resolver encoder and a 23-bit absolute encoder.

4.2 Model and nameplate

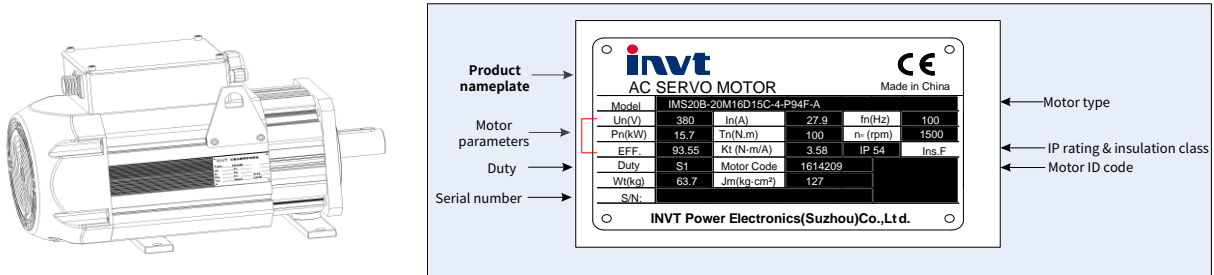

Product model		IMS20B-20 M 16D 15C-4-P9 4 F-A			
Product category IMS20B series servo motor				Internal vendor code	
Frame size 20: frame size 200 26: frame size 263				Cooling method F: Forced air cooling	
Inertia L: Low inertia M: Medium inertia H: High inertia				Optional part Empty by default: With oil seal but no brake 1: Without oil seal or brake 4: With oil seal and electromagnetic brake 5: Without oil seal but with electromagnetic brake	
Rated power Composed of base number (digits) * multiplier (letters) A: ×1 B: ×10 C: ×100 D: ×1000 eg: 40B: 0.4kW 10C: 1kW				Encoder type P9: 23-bit multi-turn absolute optical encoder R7: 12-bit resolver	
Rated speed Composed of base number (digits) * multiplier (letters) A: ×1 B: ×10 C: ×100 D: ×1000 E: ×10000 eg: 30C: 3000rpm				Voltage class 4: 380V	

4.3 Product component (frame sizes 200 and 263)

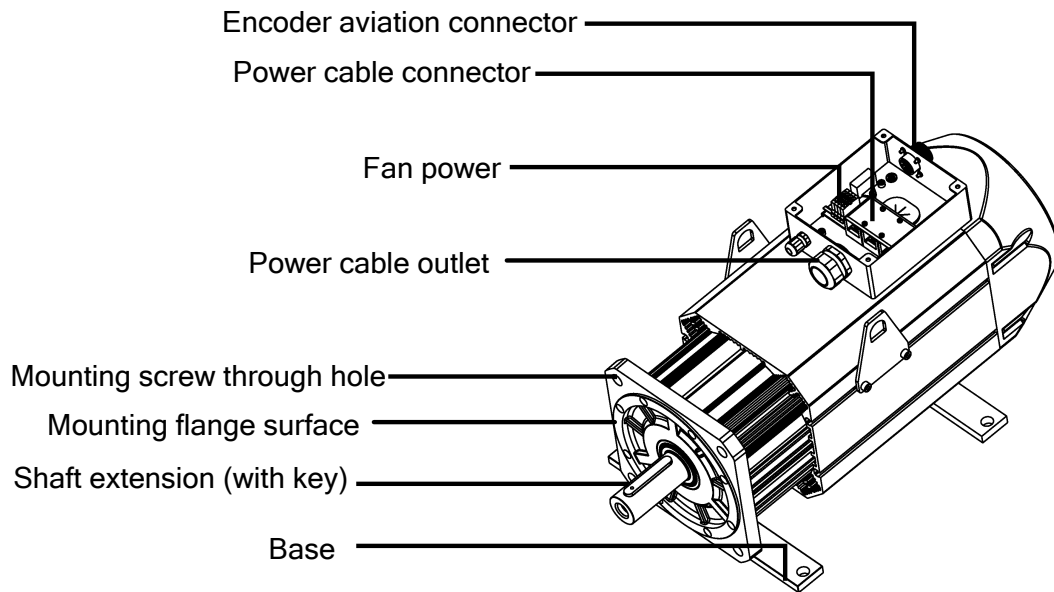

5 General specifications

5.1 Mechanical characteristics

Item	Medium-power air-cooled servo motor
Duty	S1 continuous
Running environment temperature	-20°C–40°C (no freezing)
Storage temperature	-20°C–+60°C
Running environment humidity	20%–90% RH (no condensation)
Vibration	25m/s ²
Impact	50m/s ²
Exciting method	Permanent magnetic
Installation methods	IMB35 (Horizontal with base, flange), IMB5
Insulation class	F
Insulation resistance	DC500V, > 100MΩ
Insulation voltage	AC 1500V for 1 minute (220V class); AC 1800V for 1 minute (380V class)
Enclosure IP rating	IP54 (excluding shaft extension and cable ends)
Rotation direction	Under the forward command, the rotation appears counterclockwise (CCW) when viewed from the load side.
Altitude	Below 1000 meters. For altitudes above 1000 meters, please derate. For details, refer to the altitude derating curve.

5.2 Derating characteristics

5.2.1 Derating due to altitude

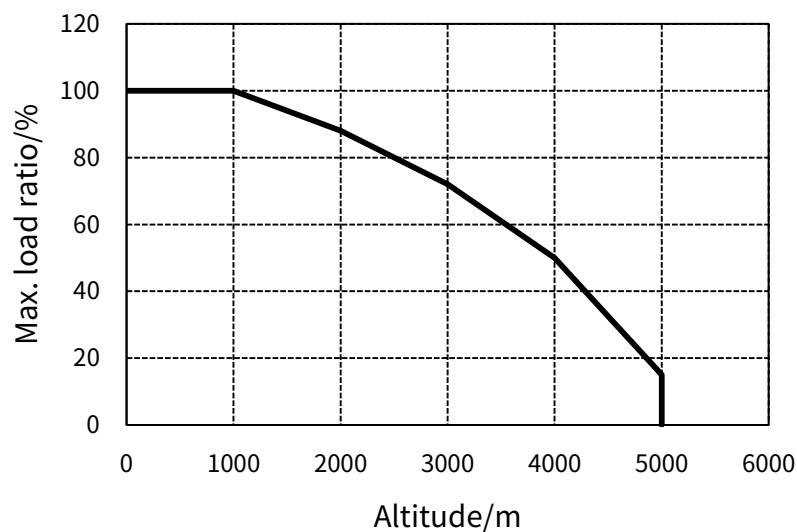

5.2.2 Derating due to temperature

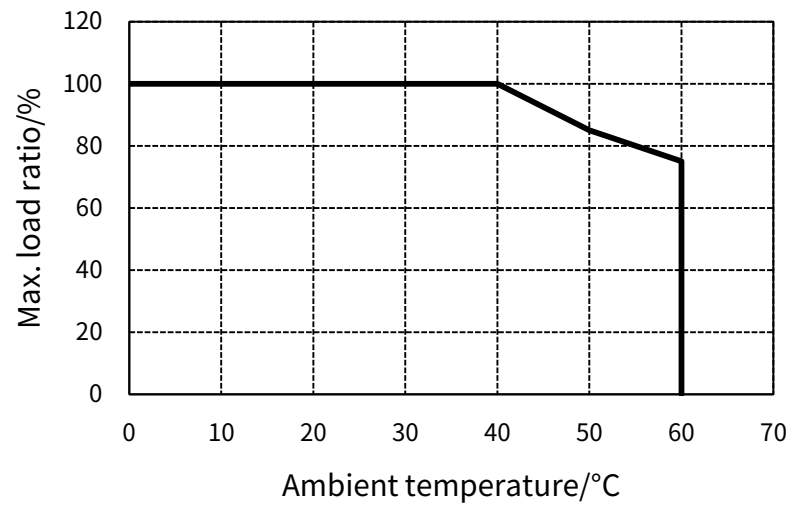

6 Medium-power air-cooled servo motor

6.1 Frame size 200

6.1.1 Motor parameters

Model	Unit	IMS20B-20M*****-4-****-A								
		63C15C	71C17C	80C20C	94C15C	11D17C	12D20C	13D15C	14D17C	17D20C
Rated voltage	V	380								
Rated speed	rpm	1500	1700	2000	1500	1700	2000	1500	1700	2000
Rated power	kW	6.3	7.1	8	9.4	10.7	12.1	12.6	14.2	16.8
Rated frequency	Hz	100	113.3	133.3	100	113.3	133.3	100	113.3	133.3
Rated current	A	12.4	13.3	14.7	16.3	19.3	20.7	22.5	25.5	29.5
Rated torque	N · m	40	40	39	60	60	58	80	80	80
Peak torque at 0.5 times the rated speed	N · m	100	100	97.5	150	150	145	200	200	200
Peak current at 0.5 times the rated speed	A	33.4	34.6	39.8	43.8	52	54.4	59.5	68.5	80
Peak torque at rated speed	N · m	79	75	76.6	125	120	124	163	169	163
Peak current at rated speed	A	28.8	30.5	34	46.4	52	58.7	57.8	68.7	77
Peak speed	rpm	2500	2700	3000	2500	2700	3000	2500	2700	3000
Peak torque at peak speed	N · m	40	43	49	63	68	77	91	102	96
Peak current at peak speed	A	22.5	25.1	29.2	34.1	39.1	47.5	45	55.9	57.8
Torque constant	N · m/A	3.23	3.05	2.65	3.68	3.08	2.80	3.56	3.14	2.71
Line resistance	Ω	2.01	1.58	1.2	1.13	0.93	0.67	0.81	0.57	0.48
Counter-emf constant	V/krpm	224	199.9	174.8	237.7	205	181.4	242.5	203.6	186.5
Rotation inertia	kg · cm ²	52 (64)	52 (64)	52 (64)	73 (85)	73 (85)	73 (85)	94 (106)	94 (106)	94 (106)
Motor weight	kg	35.2 (47.4)	35.2 (47.4)	35.2 (47.4)	40.6 (52.8)	40.6 (52.8)	40.6 (52.8)	46 (58.2)	46 (58.2)	46 (58.2)

Model	Unit	IMS20B-20M*****-4-****-A								
		16D15C	18D17C	20D20C	19D15C	21D17C	24D20C	22D15C	25D17C	27D20C
Rated voltage	V	380								
Rated speed	rpm	1500	1700	2000	1500	1700	2000	1500	1700	2000
Rated power	kW	15.7	17.8	20	18.9	21.4	24.1	22	24.9	27.4

Model	Unit	IMS20B-20M*****-4-****-A								
		16D15C	18D17C	20D20C	19D15C	21D17C	24D20C	22D15C	25D17C	27D20C
Rated frequency	Hz	100	113.3	133.3	100	113.3	133.3	100	113.3	133.3
Rated current	A	27.9	31.1	34.2	32.2	38	41.7	38.6	44.8	48.6
Rated torque	N · m	100	100	96	120	120	115	140	140	131
Peak torque at 0.5 times the rated speed	N · m	250	250	238	300	300	288	350	350	327
Peak current at 0.5 times the rated speed	A	72.7	86	90	84.4	103	110	100.7	114.2	125
Peak torque at rated speed	N · m	207	215	202	264	250	261	289	300	292
Peak current at rated speed	A	67.1	92	96	88.2	103	118	104	115	119.2
Peak speed	rpm	2500	2700	3000	2500	2700	3000	2500	2700	3000
Peak torque at peak speed	N · m	113	128	131	145	149	158	166	174	193
Peak current at peak speed	A	60.1	75.8	82.1	73.4	83.7	89.8	84	95.2	112.9
Torque constant	N · m/A	3.58	3.23	2.78	3.73	3.12	2.76	3.63	3.13	2.70
Line resistance	Ω	0.61	0.45	0.35	0.45	0.35	0.26	0.38	0.29	0.21
Counter-emf constant	V/krpm	233.3	209.8	186.5	237.9	206	181.9	240	207	176
Rotation inertia	kg · cm ²	115 (127)	115 (127)	115 (127)	135 (147)	135 (147)	135 (147)	156 (168)	156 (168)	156 (168)
Motor weight	kg	51.5 (63.7)	51.5 (63.7)	51.5 (63.7)	56.8 (69)	56.8 (69)	56.8 (69)	62.3 (74.5)	62.3 (74.5)	62.3 (74.5)

Model	Unit	IMS20B-20M*****-4-****-A								
		25D15C	29D17C	32D20C	28D15C	32D17C	36D20C	31D15C	36D17C	40D20C
Rated voltage	V	380								
Rated speed	rpm	1500	1700	2000	1500	1700	2000	1500	1700	2000
Rated power	kW	25.1	28.5	31.6	28.3	32	35.6	31	36	40
Rated frequency	Hz	100	113.3	133.3	100	113.3	133.3	100	113.3	133.3
Rated current	A	43.3	51.4	54	47.5	55.7	62.2	55	61	66
Rated torque	N · m	160	160	151	180	180	170	200	200	190
Peak torque at 0.5 times the rated speed	N · m	400	400	376	450	450	424	500	500	475
Peak current at 0.5 times the rated speed	A	109.3	136	139	118.9	146.9	154	140	158	168
Peak torque at rated speed	N · m	322	350	330	380	396	365	438	434	405
Peak current at rated speed	A	100.8	139	138	125.6	154.4	155	131.7	147.2	161.3
Peak speed	rpm	2500	2700	3000	2500	2700	3000	2500	2700	3000

Model	Unit	IMS20B-20M*****-4-****-A								
		25D15C	29D17C	32D20C	28D15C	32D17C	36D20C	31D15C	36D17C	40D20C
Peak torque at peak speed	N · m	191	204	200	210	215	239	260	264	267
Peak current at peak speed	A	94.8	113.7	119.1	113	123.5	131.9	131	139.2	147.4
Torque constant	N · m/A	3.70	3.11	2.71	3.79	3.14	2.73	3.64	3.28	2.88
Line resistance	Ω	0.31	0.23	0.19	0.3	0.2	0.17	0.224	0.186	0.144
Counter-emf constant	V/krpm	243.3	205.2	186.5	252.6	208	186	231.1	210.7	185.2
Rotation inertia	kg · cm ²	177	177	177	196	196	196	230	230	230
Motor weight	kg	67.7	67.7	67.7	73.1	73.1	73.1	78	78	78

Note: The data in parentheses refers to the brake motor specifications. Peak current at peak speed is consistent with the peak current at rated speed.

Brake parameter									Allowable load	
Holding torque (N · m)	Resistance (Ω)	Supply voltage (DC V)	Rated power (W)	Pick-up voltage (V)	Drop-out voltage (V)	Pick-up time (ms)	Drop-out time (ms)	Rotational backlash (°)	Radial allowable load (N)	Axial allowable load (N)
≥150	10.5±7%	24±10%	55	≤18	≥1.2	≤350	≤80	≤1	1200	250

Centrifugal fan parameter					
Rated voltage (V)	Frequency (Hz)	Rated power (W)	Rated speed (rpm)	Noise (dB)	IP rating
220±10%	50/60	50/64	2600/2850	66/68	IP54

6.1.2 Motor dimensions

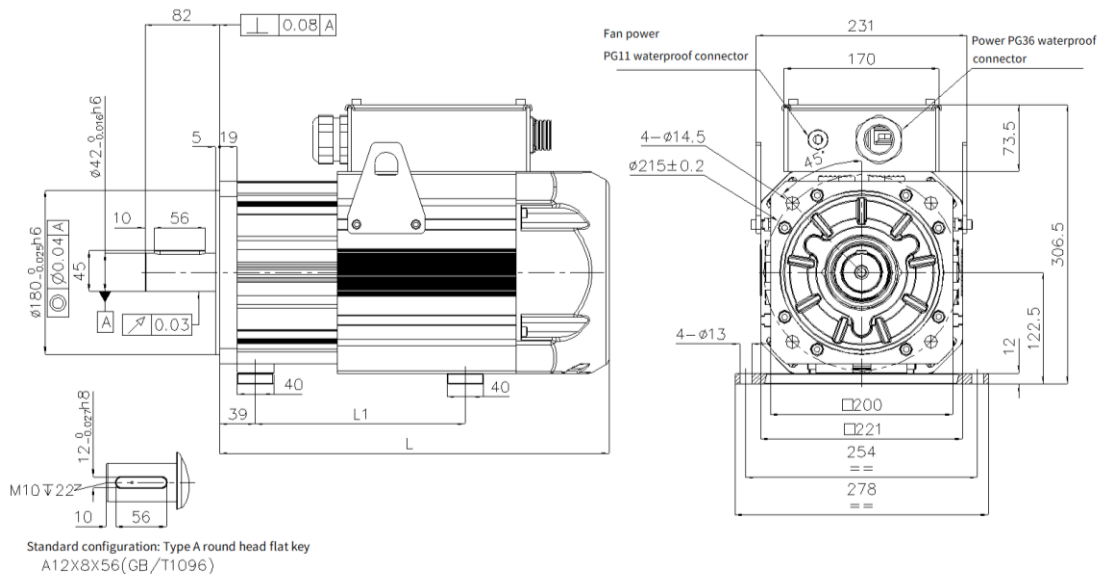

Product model	L1 (mm)	L (mm)
IMS20B-20M63C15C-4-****-A	165(225)	343(417)
IMS20B-20M71C17C-4-****-A	165(225)	343(417)

Product model	L1 (mm)	L (mm)
IMS20B-20M80C20C-4-****-A	165(225)	343(417)
IMS20B-20M94C15C-4-****-A	190(250)	371(445)
IMS20B-20M11D17C-4-****-A	190(250)	371(445)
IMS20B-20M12D20C-4-****-A	190(250)	371(445)
IMS20B-20M13D15C-4-****-A	220(280)	399(473)
IMS20B-20M14D17C-4-****-A	220(280)	399(473)
IMS20B-20M17D20C-4-****-A	220(280)	399(473)
IMS20B-20M16D15C-4-****-A	230(290)	427(501)
IMS20B-20M18D17C-4-****-A	230(290)	427(501)
IMS20B-20M20D20C-4-****-A	230(290)	427(501)
IMS20B-20M19D15C-4-****-A	270(330)	455(529)
IMS20B-20M21D17C-4-****-A	270(330)	455(529)
IMS20B-20M24D20C-4-****-A	270(330)	455(529)
IMS20B-20M22D15C-4-****-A	300(360)	483(557)
IMS20B-20M25D17C-4-****-A	300(360)	483(557)
IMS20B-20M27D20C-4-****-A	300(360)	483(557)
IMS20B-20M25D15C-4-****-A	340	511
IMS20B-20M29D17C-4-****-A	340	511
IMS20B-20M32D20C-4-****-A	340	511
IMS20B-20M28D15C-4-****-A	360	539
IMS20B-20M32D17C-4-****-A	360	539
IMS20B-20M36D20C-4-****-A	360	539
IMS20B-20M31D15C-4-****-A	390	567
IMS20B-20M36D17C-4-****-A	390	567
IMS20B-20M40D20C-4-****-A	390	567

 **Note:** The data in parentheses refers to the brake motor specifications.

6.1.3 External characteristic curve

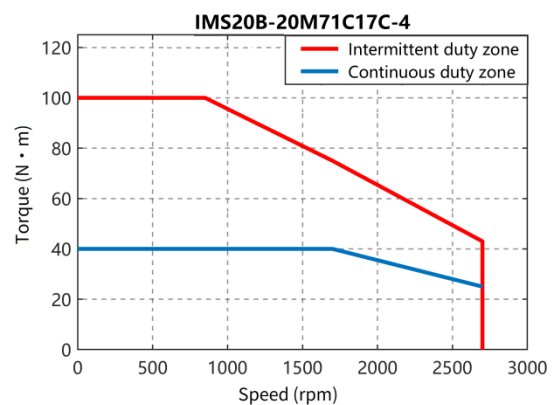
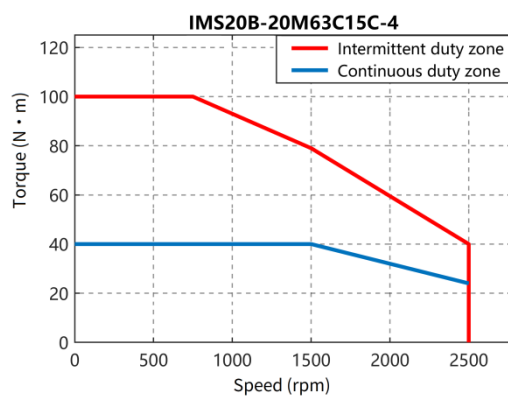

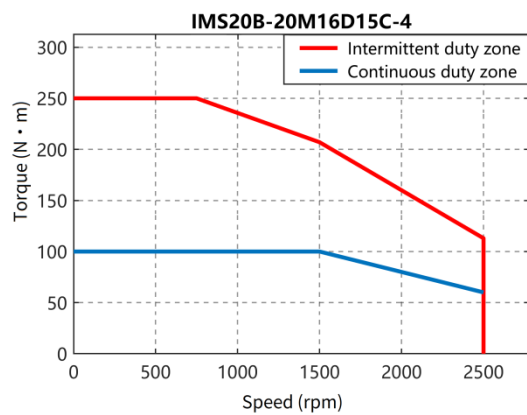
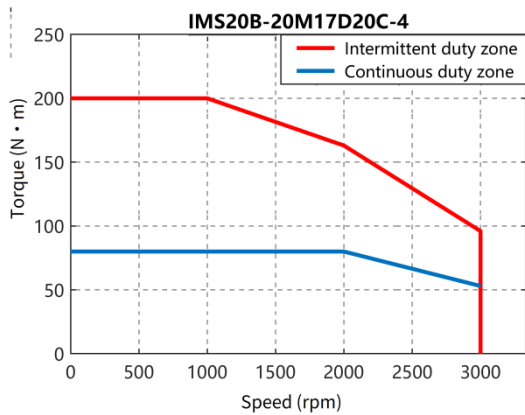
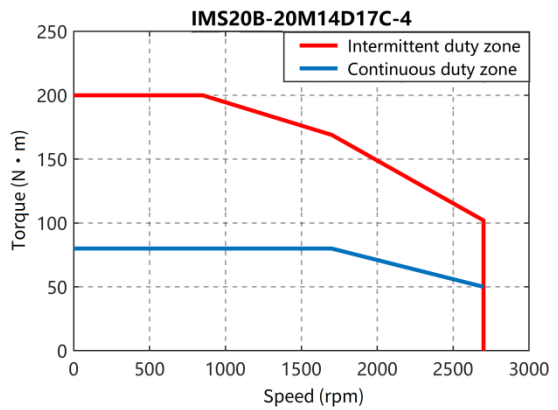
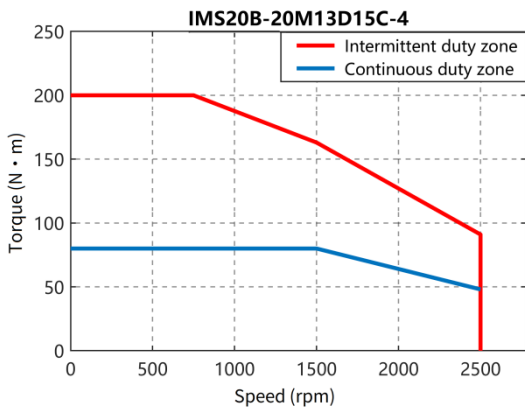
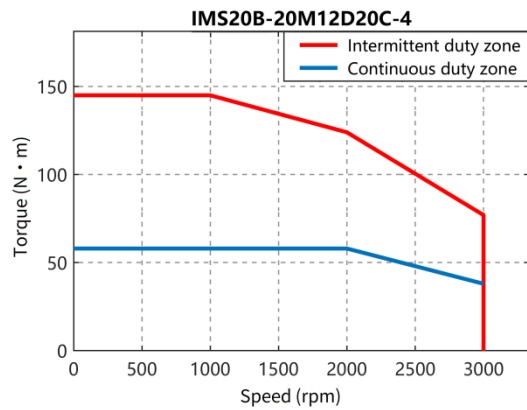
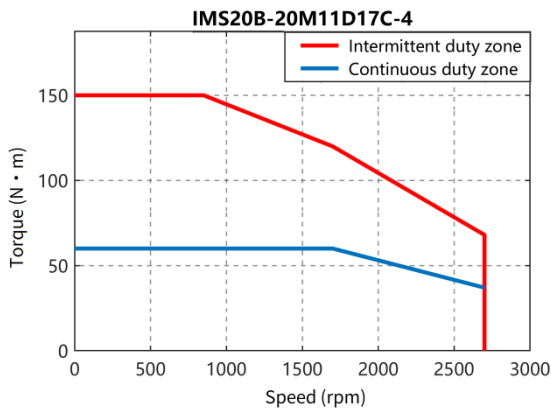
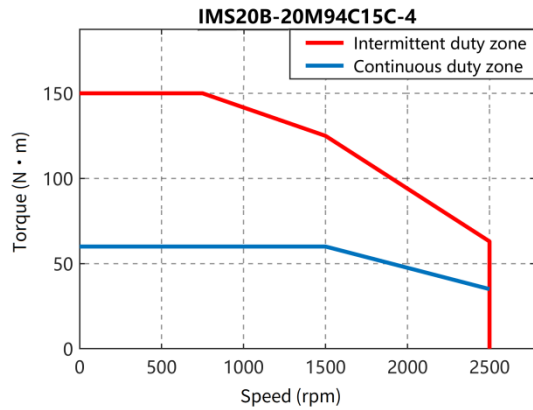
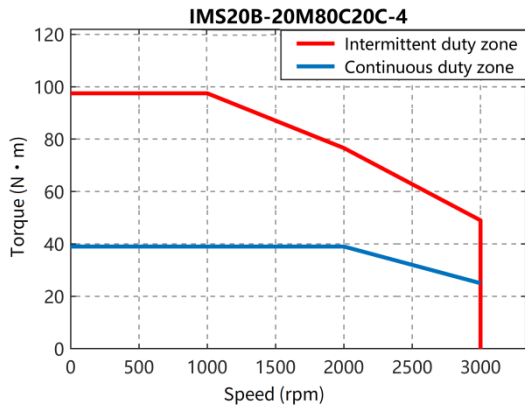

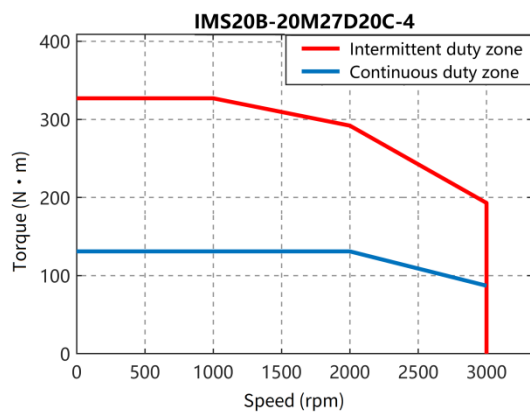
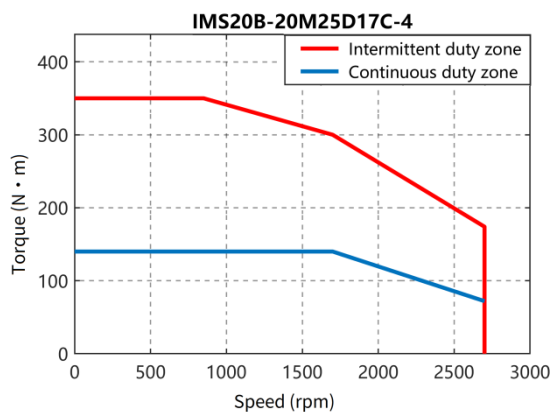
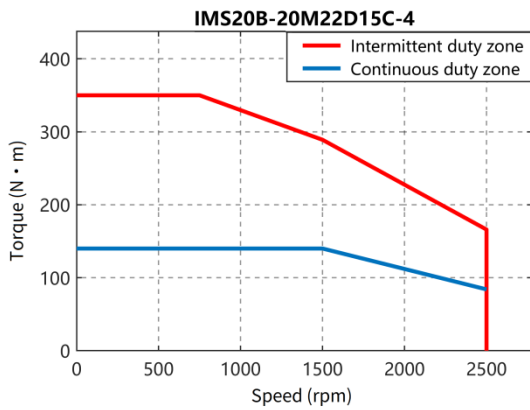
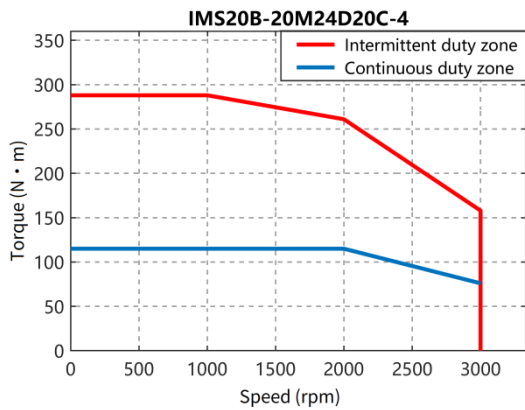
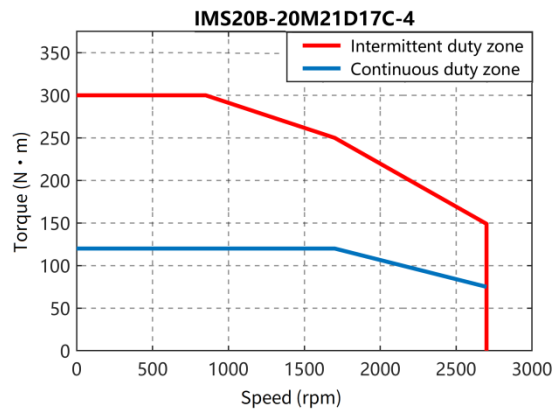
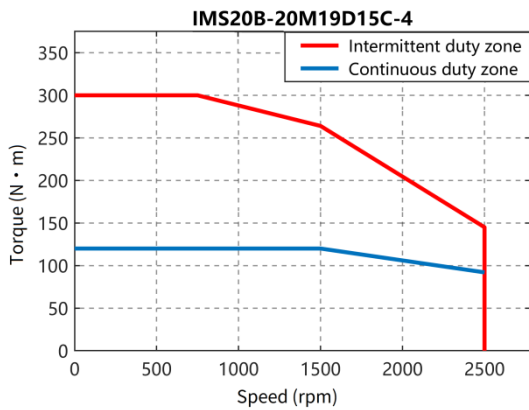
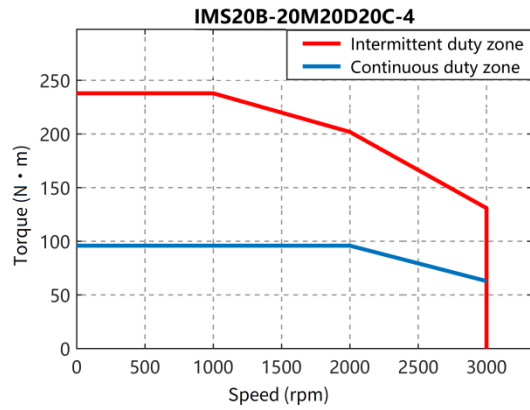
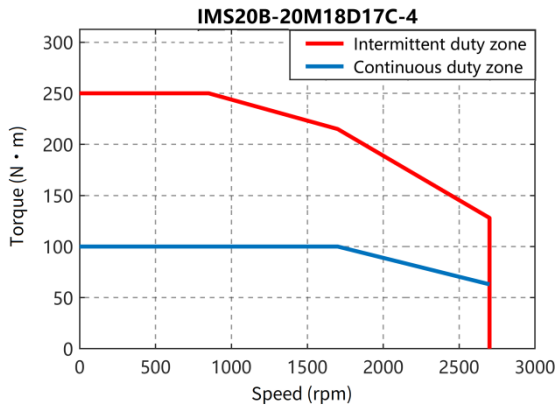

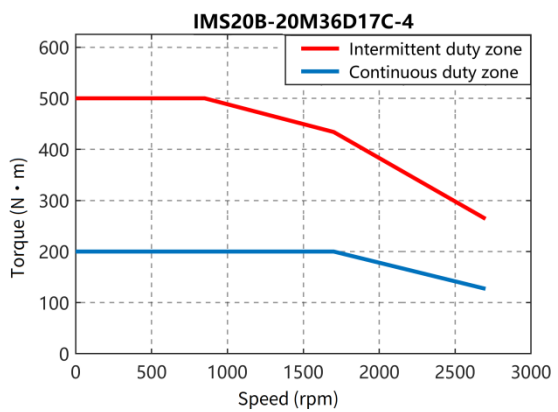
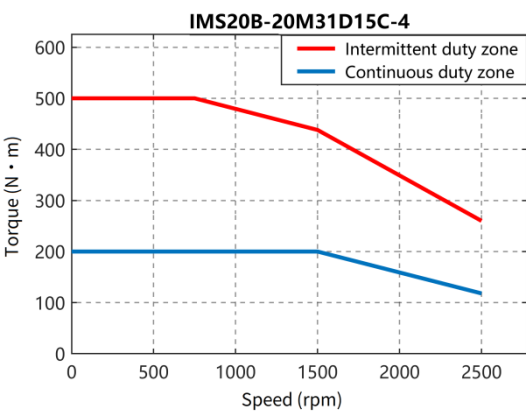
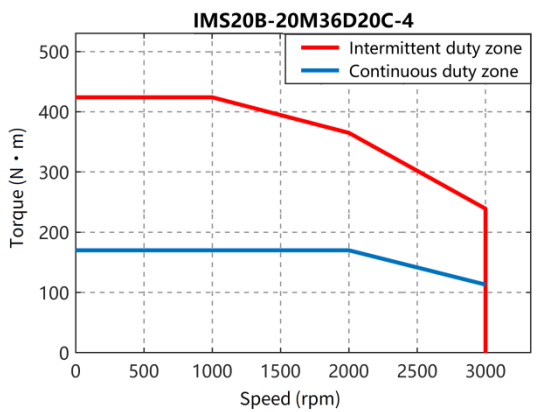
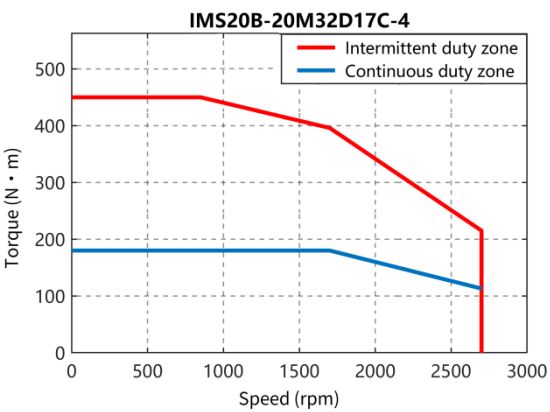
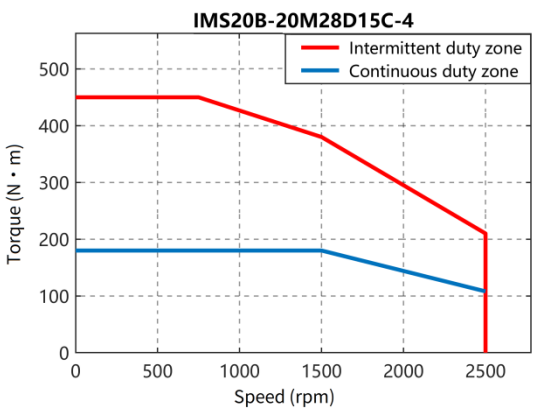
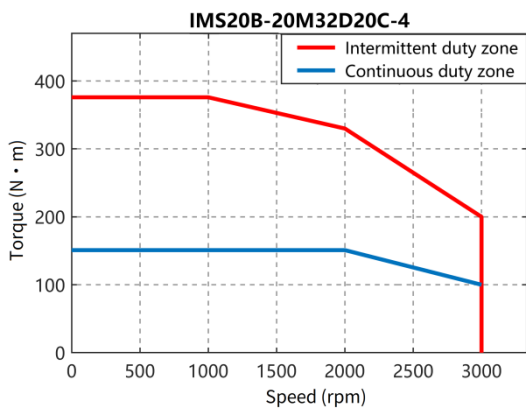
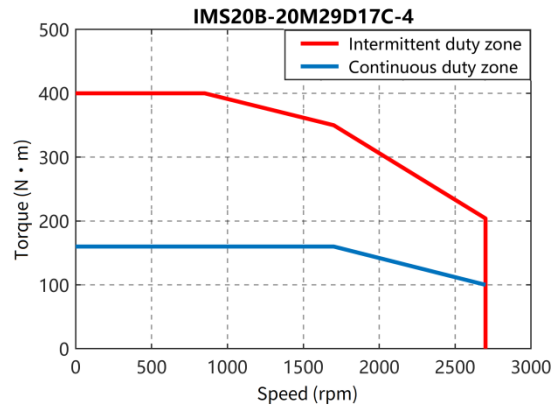
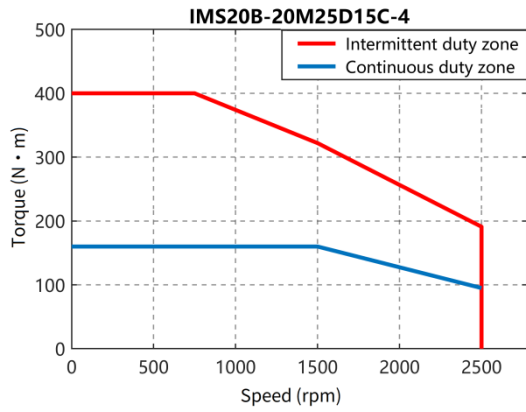

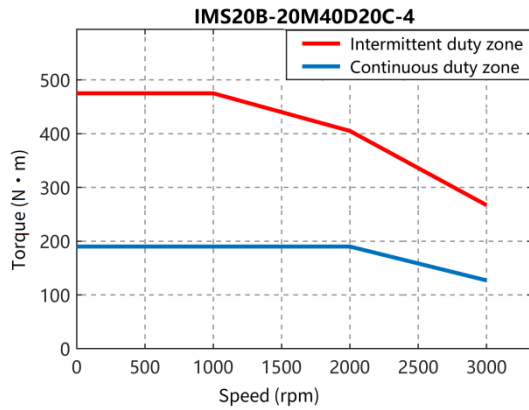

6.2 Frame size 263

6.2.1 Motor parameters

Model	Unit	IMS20B-26M*****-4-****-A								
		28D15C	32D17C	37D20C	35D15C	39D17C	45D20C	41D15C	46D17C	50D20C
Rated voltage	V	380								
Rated speed	rpm	1500	1700	2000	1500	1700	2000	1500	1700	2000
Rated power	kW	28	32	37	34.6	39	45	40.8	46	49.8
Rated frequency	Hz	100	113.3	133.3	100	113.3	133.3	100	113.3	133.3
Rated current	A	50.4	58.8	65.7	64.1	65.1	81.2	71.4	81.3	86.6
Rated torque	N·m	180	180	175	221	217	214	260	259	238
Peak torque at 0.5 times the rated speed	N·m	450	450	438	553	543	535	650	648	595
Peak current at 0.5 times the rated speed	A	148.1	167.1	191.9	165.2	179.2	220.6	207.0	223.7	220.0
Peak torque at rated speed	N·m	331	350	346	420	412	436	505	509	429
Peak current at rated speed	A	117.2	141.1	165.5	150.5	159.1	204.3	179.3	197.9	190.6
Peak speed	rpm	2500	2700	3000	2500	2700	3000	2500	2700	3000
Peak torque at peak speed	N·m	183	196	210	224	229	263	275	285	281
Peak current at peak speed	A	90.6	103.9	122.3	118.7	131.2	153.3	140.3	143.9	157.7
Torque constant	N·m/A	3.57	3.06	2.66	3.45	3.33	2.64	3.64	3.19	2.75
Line resistance	Ω	0.281	0.216	0.150	0.202	0.175	0.117	0.159	0.131	0.103
Counter-emf constant	V/krpm	233.3	196.2	168.6	224.3	214.3	167.95	230.4	202.9	181.1
Rotation inertia	kg·cm ²	242 (260)	242 (260)	242 (260)	297 (315)	297 (315)	297 (315)	351	351	351
Motor weight	kg	82 (95)	82 (95)	82 (95)	93 (106)	93 (106)	93 (106)	104	104	104

Model	Unit	IMS20B-26M*****-4-****-A								
		47D15C	53D17C	58D20C	53D15C	61D17C	65D20C	60D15C	68D17C	74D20C
Rated voltage	V	380								
Rated speed	rpm	1500	1700	2000	1500	1700	2000	1500	1700	2000
Rated power	kW	47	53	58	53.4	60.5	65	60	67.6	74
Rated frequency	Hz	100	113.3	133.3	100	113.3	133.3	100	113.3	133.3
Rated current	A	82.2	93.3	99.7	92.9	101.7	113	104.7	118.8	127.1
Rated torque	N · m	300	300	276	340	340	310	382	380	351
Peak torque at 0.5 times the rated speed	N · m	750	750	690	850	850	775	955	950	878
Peak current at 0.5 times the rated speed	A	220.2	241.6	241.4	236.7	276.0	267.7	264.4	312.1	344.9
Peak torque at rated speed	N · m	585	510	551	608	665	636	753	711	769
Peak current at rated speed	A	203.9	190.1	235.2	207.1	255.3	258	259.7	284.8	330.6
Peak speed	rpm	2500	2700	3000	2500	2700	3000	2500	2700	3000
Peak torque at peak speed	N · m	312	320	328.6	353	373	400	414	446	486
Peak current at peak speed	A	152.9	178.2	185.6	175	201.5	248.9	209.3	241.4	297.6
Torque constant	N · m/A	3.65	3.19	2.77	3.66	3.34	2.74	3.65	3.2	2.76
Line resistance	Ω	0.143	0.114	0.088	0.128	0.098	0.071	0.107	0.079	0.055
Counter-emf constant	V/krpm	241.5	210.9	185	245.7	218.4	180.6	242.2	203.2	175.7
Rotation inertia	kg · cm ²	406	406	406	461	461	461	515	515	515
Motor weight	kg	115	115	115	126	126	126	137	137	137

Model	Unit	IMS20B-26M*****-4-****-A					
		66D15C	75D17C	82D20C	78D15C	86D17C	90D20C
Rated voltage	V	380					
Rated speed	rpm	1500	1700	2000	1500	1700	2000
Rated power	kW	66	75	82	78	86	90
Rated frequency	Hz	100	113.3	133.3	100	113.3	133.3
Rated current	A	120	141	138	151	152	148
Rated torque	N · m	420	420	392	495	485	430
Peak torque at 0.5 times the rated speed	N · m	1050	1050	980	1238	1213	1075
Peak current at 0.5 times the rated speed	A	321.2	361.6	343.9	426.4	409.8	344.6
Peak torque at rated speed	N · m	908	906	798	1098.3	928	778
Peak current at rated speed	A	309.7	333.5	333.6	393.5	353.6	333.9
Peak speed	rpm	2500	2700	3000	2500	2700	3000

Product model	L1 (mm)	L (mm)
IMS20B-26M28D15C-4-****-A	255(300)	523(608)
IMS20B-26M32D17C-4-****-A	255(300)	523(608)
IMS20B-26M37D20C-4-****-A	255(300)	523(608)
IMS20B-26M35D15C-4-****-A	300(370)	563(648)
IMS20B-26M39D17C-4-****-A	300(370)	563(648)
IMS20B-26M45D20C-4-****-A	300(370)	563(648)
IMS20B-26M41D15C-4-****-A	370	603
IMS20B-26M46D17C-4-****-A	370	603
IMS20B-26M50D20C-4-****-A	370	603
IMS20B-26M47D15C-4-****-A	400	643
IMS20B-26M53D17C-4-****-A	400	643
IMS20B-26M58D20C-4-****-A	400	643
IMS20B-26M53D15C-4-****-A	440	683
IMS20B-26M61D17C-4-****-A	440	683
IMS20B-26M65D20C-4-****-A	440	683
IMS20B-26M60D15C-4-****-A	480	723
IMS20B-26M68D17C-4-****-A	480	723
IMS20B-26M74D20C-4-****-A	480	723
IMS20B-26M66D15C-4-****-A	520	763
IMS20B-26M75D17C-4-****-A	520	763
IMS20B-26M82D20C-4-****-A	520	763
IMS20B-26M78D15C-4-****-A	560	803
IMS20B-26M86D17C-4-****-A	560	803
IMS20B-26M90D20C-4-****-A	560	803

 **Note:** The data in parentheses refers to the brake motor specifications.

6.2.3 External characteristic curve

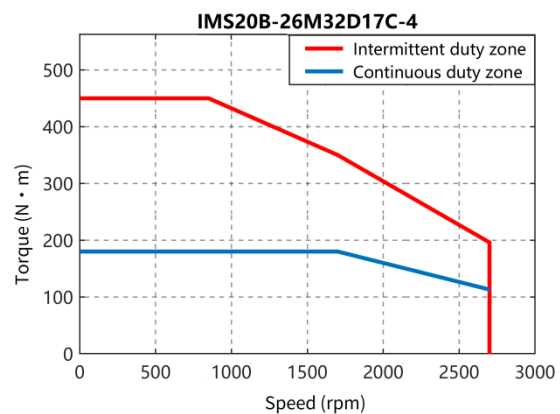
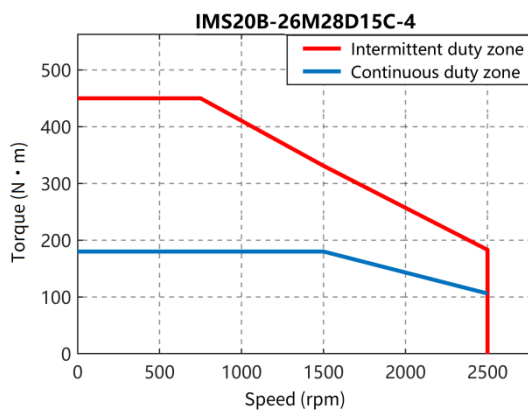

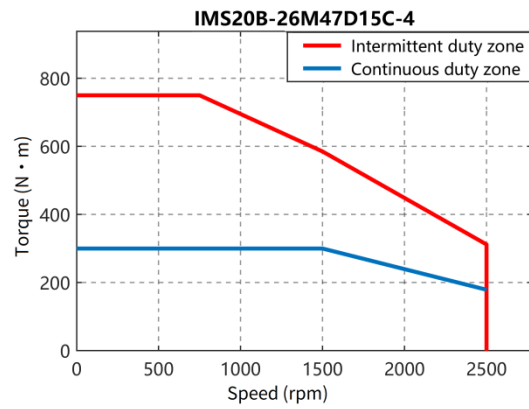
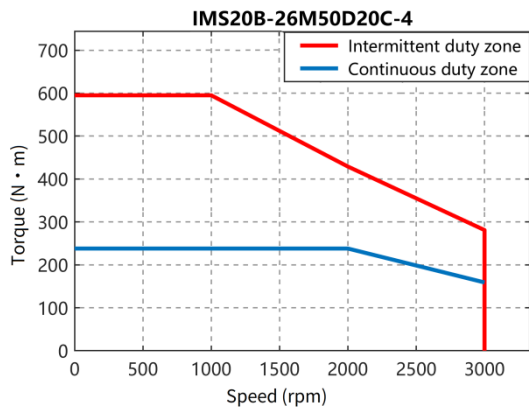
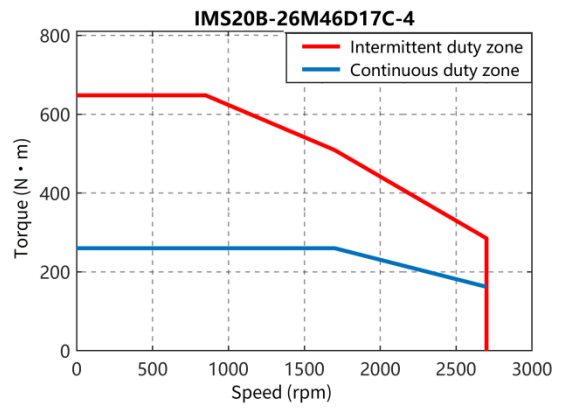
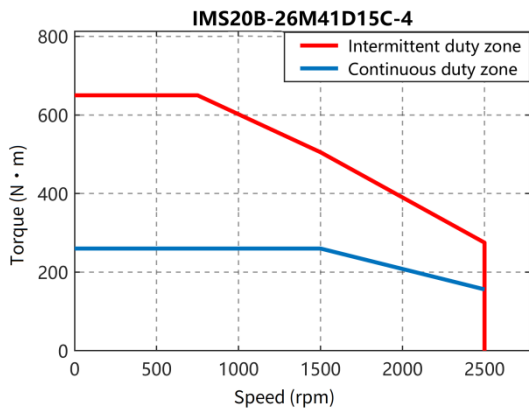
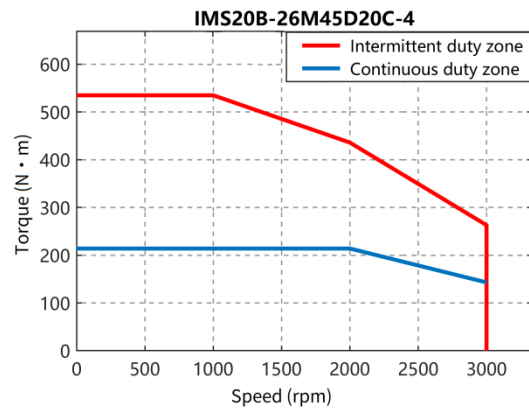
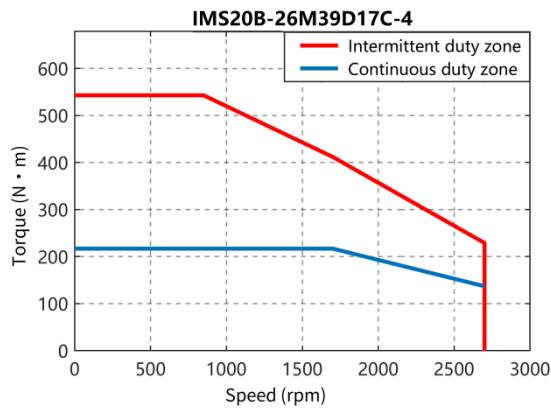
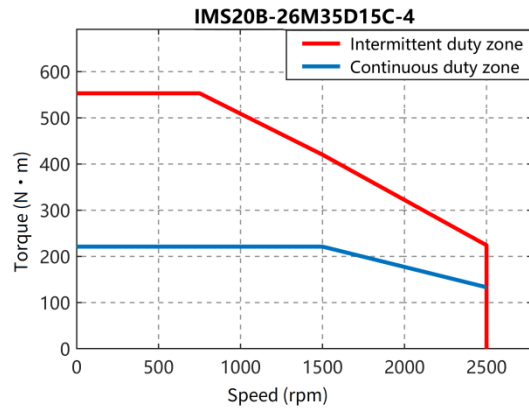
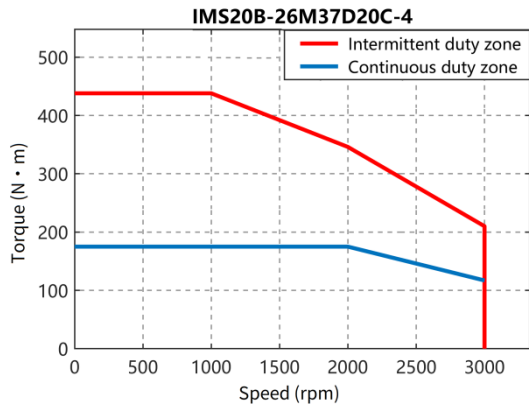

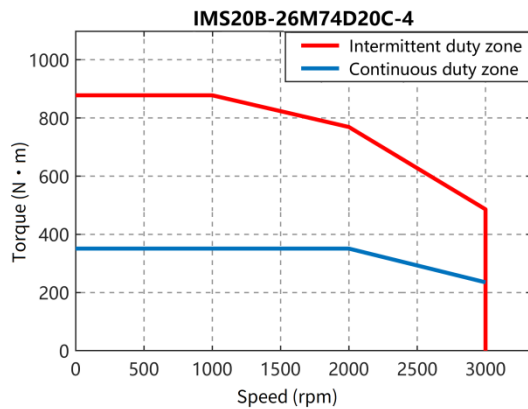
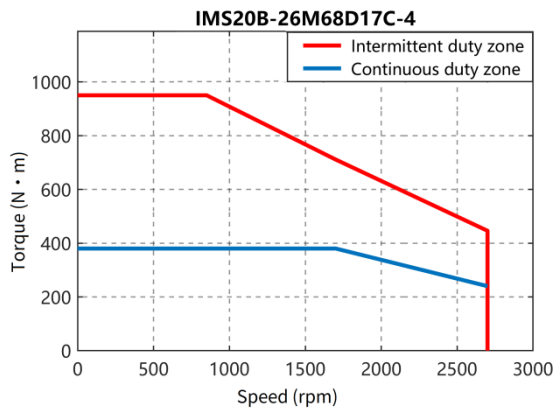
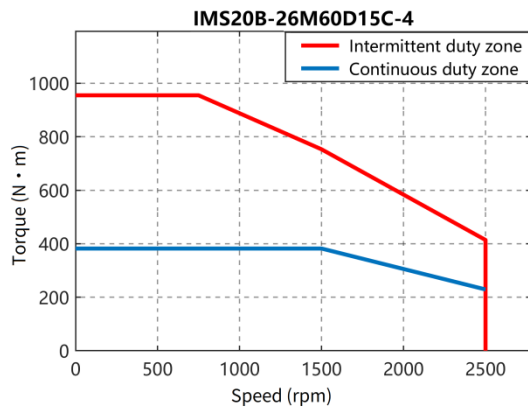
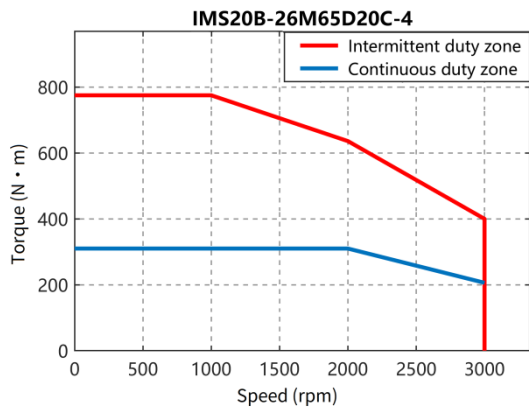
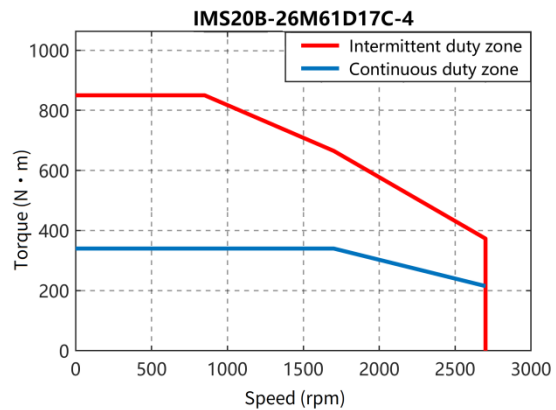
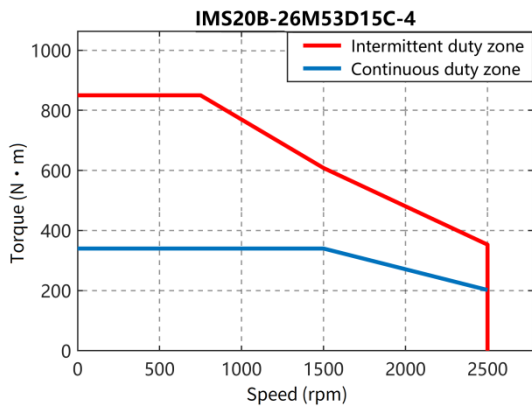
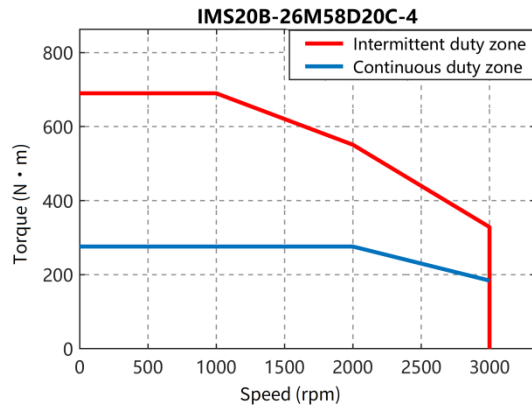
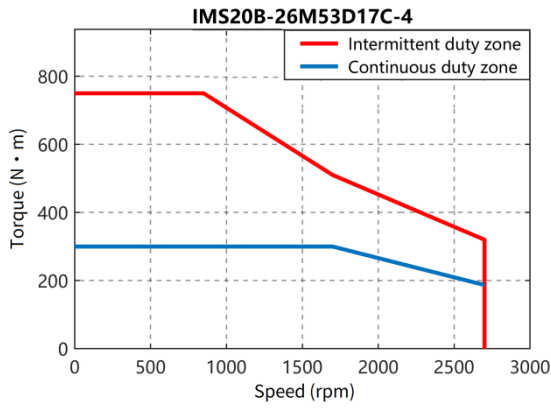

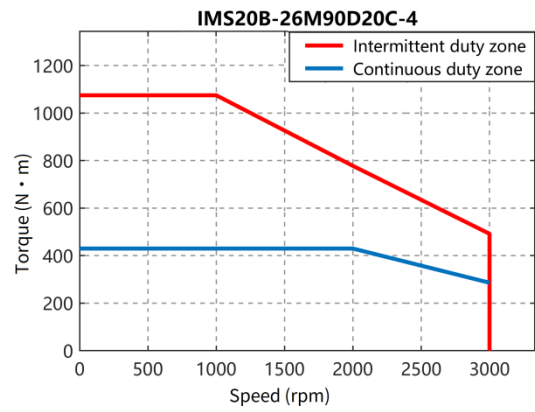
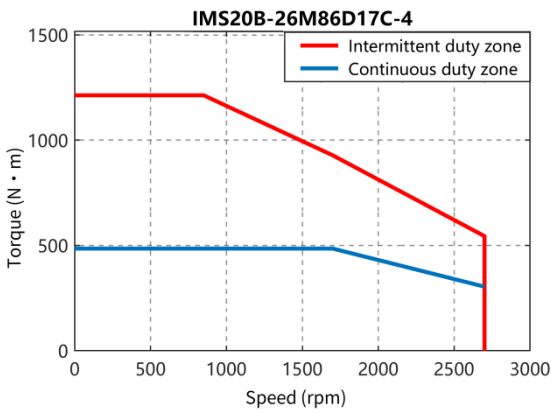
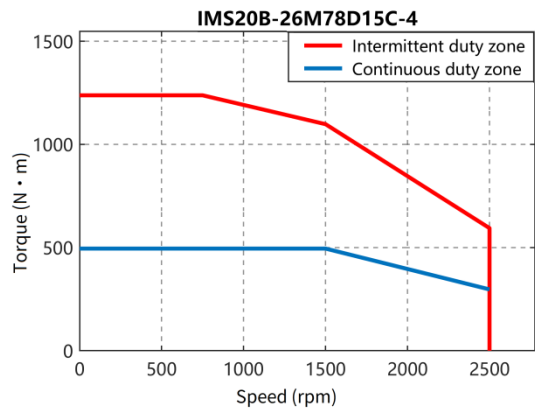
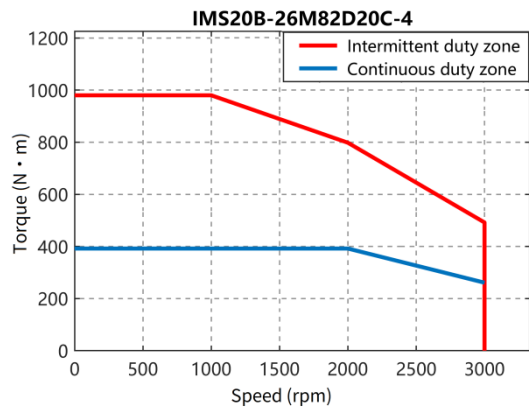
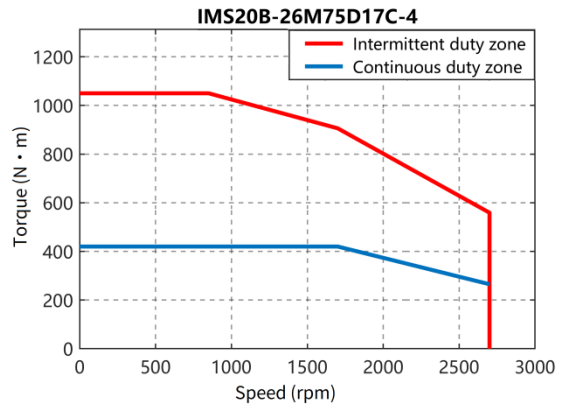
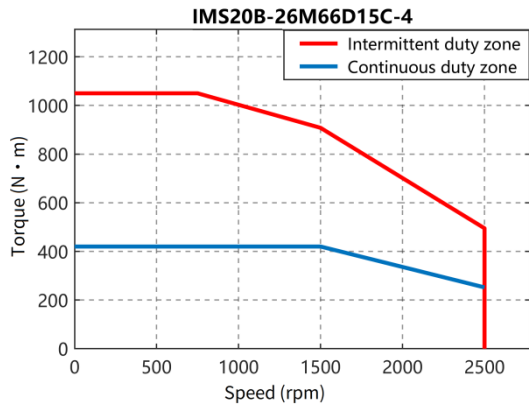

7 Motor terminal and junction box

7.1.1 Encoder terminal

Figure 7-1 Encoder terminal outline (YD28J15ZF)

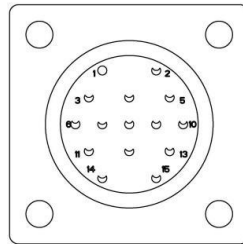

Pin No.	1	2	3	4	5	6	7	8	9
Pin definition for 23-bit single-/multi-turn absolute encoder	PE+	SD+	SD-	5V	GND	VB_5V	VB_GND	KTY84-130+	KTY84-130-
Pin definition for 12-bit resolver	PE	Ref+	Ref-	Cos-	Cos+	Sin+	Sin-	KTY84-130+	KTY84-130-

7.1.2 Terminal box component

Figure 7-2 Components of the standard motor terminal box

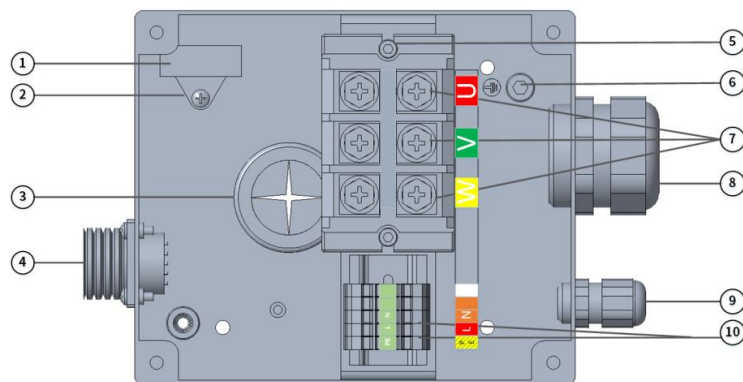

No.	Component name
①	Fan capacitor
②	M4 hex socket screw
③	Motor outlet hole (Avoid dropping small parts or foreign objects)
④	YD28 aviation connector
⑤	2-M5 hex socket screw
⑥	M8 (M6) connection junction box and housing/grounding marking
⑦	M8 bolt for UVW power line

No.	Component name
⑧	PG36 water-proof connector
⑨	PG11 water-proof connector
⑩	220V fan power terminal

Figure 7-3 Components of the brake motor terminal box

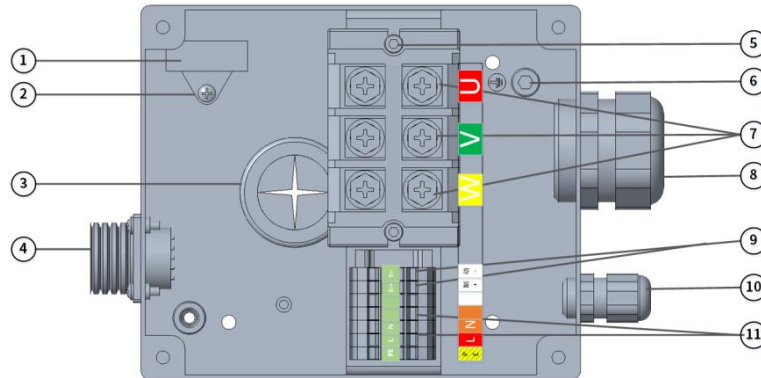

No.	Component name
①	Fan capacitor
②	M4 hex socket screw
③	Motor outlet hole (Avoid dropping small parts or foreign objects)
④	YD28 aviation connector
⑤	2-M5 hex socket screw
⑥	M8 (M6) connection junction box and housing/grounding marking
⑦	M8 bolt for UVW power line
⑧	PG36 water-proof connector
⑨	Brake 24V power supply terminal
⑩	PG11 water-proof connector
⑪	220V fan power terminal

7.1.3 Terminal box dimension

Product model	Dimension drawings
IMS20B-20M63C15C-4-****-A	<p>PG11 waterproof connector: Suitable cable diameter (5-10)mm</p> <p>PG36 waterproof connector: Suitable cable diameter (25-32)mm</p>
IMS20B-20M71C17C-4-****-A	
IMS20B-20M80C20C-4-****-A	
IMS20B-20M94C15C-4-****-A	
IMS20B-20M11D17C-4-****-A	
IMS20B-20M12D20C-4-****-A	

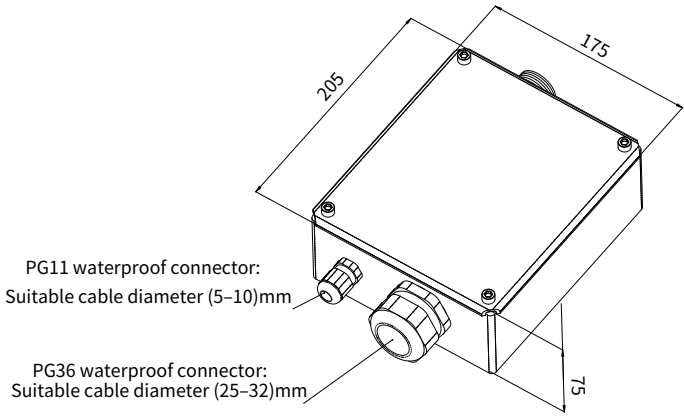
Product model	Dimension drawings
IMS20B-20M13D15C-4-****-A	 <p data-bbox="638 1120 925 1187">PG11 waterproof connector: Suitable cable diameter (5-10)mm</p> <p data-bbox="638 1220 941 1288">PG36 waterproof connector: Suitable cable diameter (25-32)mm</p>
IMS20B-20M14D17C-4-****-A	
IMS20B-20M17D20C-4-****-A	
IMS20B-20M16D15C-4-****-A	
IMS20B-20M18D17C-4-****-A	
IMS20B-20M20D20C-4-****-A	
IMS20B-20M19D15C-4-****-A	
IMS20B-20M21D17C-4-****-A	
IMS20B-20M24D20C-4-****-A	
IMS20B-20M22D15C-4-****-A	
IMS20B-20M25D17C-4-****-A	
IMS20B-20M27D20C-4-****-A	
IMS20B-20M25D15C-4-****-A	
IMS20B-20M29D17C-4-****-A	
IMS20B-20M32D20C-4-****-A	
IMS20B-20M28D15C-4-****-A	
IMS20B-20M32D17C-4-****-A	
IMS20B-20M36D20C-4-****-A	
IMS20B-20M31D15C-4-****-A	
IMS20B-20M36D17C-4-****-A	
IMS20B-20M40D20C-4-****-A	
IMS20B-26M28D15C-4-****-A	
IMS20B-26M32D17C-4-****-A	
IMS20B-26M37D20C-4-****-A	
IMS20B-26M35D15C-4-****-A	
IMS20B-26M39D17C-4-****-A	
IMS20B-26M45D20C-4-****-A	
IMS20B-26M41D15C-4-****-A	
IMS20B-26M46D17C-4-****-A	
IMS20B-26M50D20C-4-****-A	
IMS20B-26M47D15C-4-****-A	
IMS20B-26M53D17C-4-****-A	
IMS20B-26M58D20C-4-****-A	
IMS20B-26M53D15C-4-****-A	
IMS20B-26M61D17C-4-****-A	
IMS20B-26M65D20C-4-****-A	
IMS20B-26M60D15C-4-****-A	
IMS20B-26M68D17C-4-****-A	
IMS20B-26M74D20C-4-****-A	
IMS20B-26M66D15C-4-****-A	
IMS20B-26M75D17C-4-****-A	
IMS20B-26M82D20C-4-****-A	
IMS20B-26M78D15C-4-****-A	
IMS20B-26M86D17C-4-****-A	
IMS20B-26M90D20C-4-****-A	

8 Installation instructions

8.1 Unpacking inspection

After receiving the product, please perform the following checks to ensure the safe use of the product.

■ Inspecting the packaging

Before unpacking, check whether the product package is intact—whether the package is damaged, dampened, soaked, or deformed. After unpacking, check whether the interior surface of the packing box is abnormal, for example, in wet condition.

■ Inspecting the machine and its components

After unpacking, check whether the equipment enclosure is damaged or cracked, whether the parts inside the packing box are complete, and whether the nameplate and label on the product body are consistent with the model ordered.

8.2 Mechanical installation

8.2.1 Preparing

■ Safety instructions



Only qualified personnel who have received training are allowed to perform the tasks described in this chapter. Please read the following installation preparations carefully before proceeding with the installation to ensure a smooth process and to avoid personal injury or equipment damage.

Item	Description
	<p>Carry out operations according to the safety instructions. Ensure the motor power has been disconnected before installation. If the motor has been powered on, disconnect the drive and wait for at least 15 minutes, and ensure the POWER indicator is off before proceeding to the next step.</p> <p>The motor installation must be designed and done according to applicable local laws and regulations. We do not assume any liability whatsoever for any equipment installation which breaches local laws or regulations.</p>

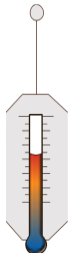

■ Installation environment and site

● Environment requirements

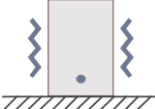
Environment	Requirement	
Temperature		<ul style="list-style-type: none"> ● Refer to the motor mechanical characteristics description. ● There is no sudden temperature change. ● When the equipment is installed in a closed space, such as control cabinet, use a cooling fan or air conditioner for cooling when necessary. ● When the temperature is too low, if you want to use the equipment that has been idled for a long time, install an external heating device before the use to eliminate the freeze inside the equipment. Otherwise, the equipment may be damaged.

Environment	Requirement	
Humidity		<ul style="list-style-type: none"> See section 5.1 Mechanical characteristics. The max. RH cannot exceed 60% in the environment with corrosive gases.
Altitude		<ul style="list-style-type: none"> Lower than 1000m When the altitude exceeds 1000m, please derate according to the altitude derating curve. When the altitude exceeds 3000m, consult our local dealer or office for details.
Vibration		<ul style="list-style-type: none"> See section 5.1 Mechanical characteristics.

● **Site requirement**

Site	Requirement	
Indoor		<ul style="list-style-type: none"> Without electromagnetic radiation sources and direct sunlight. Note: The motor must be installed in a clean and well-ventilated environment based on the housing IP rating.
		<ul style="list-style-type: none"> Without foreign objects such as oil mist, metal powder, conductive dust, and water.
		<ul style="list-style-type: none"> Without radioactive, corrosive, hazard, and combustible and explosive substances. Note: Do not install the motor onto combustible objects.
		<ul style="list-style-type: none"> With low salt content.

8.2.2 Installation method

The installation procedures are as follows:

Step 1 Clear the installation area and prepare the necessary tools and components.

Step 2 Check and confirm that all components are in good condition and that the motor operates normally.

Step 3 Choose an appropriate installation method to ensure that the drive center axis is aligned and does not exceed the allowable tolerance range. Secure the motor using bolts, avoiding any striking to prevent damage.

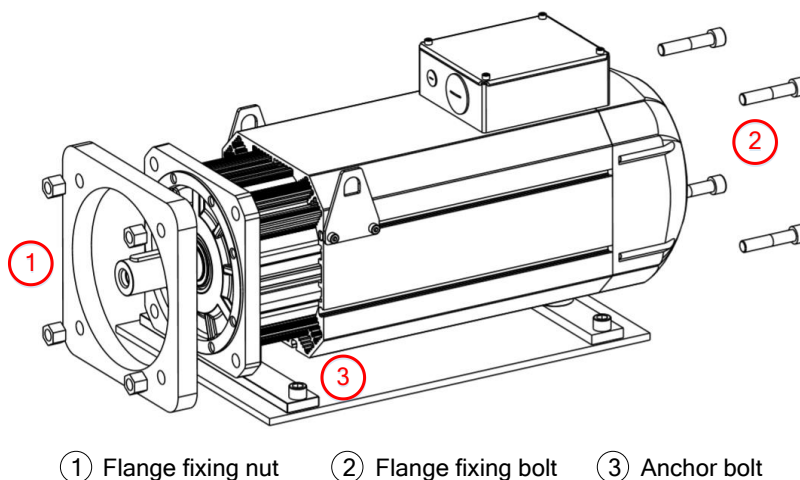

① Flange fixing nut ② Flange fixing bolt ③ Anchor bolt

Note:

- During the handling of the motor, do not pull on the motor leads or output shaft. It is recommended to use the lifting lugs on both sides of the motor for hoisting.
- The IMB35 mounting standard is recommended for installation. The flange and base must be secured on a flat supporting surface. If there is a height difference between the motor and the driven machinery, shimming must be done, and the area of the shim must be larger than the area of the motor's base.
- When using a coupling for transmission, the motor's shaft centerline must coincide with the load's shaft centerline.
- During installation, ensure that all mounting holes are securely locked with steel bolts (strength grade 8.8 or higher) and nuts. In areas prone to rust, stainless steel bolts should be used, and in high-vibration environments, anti-vibration pads should be installed.
- Do not strike or hammer during the motor assembly to avoid damage to the encoder or shafts.
- After installation, check each component individually, and only start trial operation after confirming that all connections are secure.
- Please wipe the slushing oil on the motor shaft before using.

8.3 Check after installation

After installation, please conduct inspections in sequence according to the following table:

Check item	Content	Confirmation
Ambient environment	Ambient temperature is less than 40°C.	<input type="checkbox"/>
	RH is less than 90%.	<input type="checkbox"/>
	Vibration acceleration is less than 0.5G (4.9m/s ²).	<input type="checkbox"/>
	No dust, corrosive gases, or oil contamination.	<input type="checkbox"/>
	No tools or foreign objects (including cable ends, metal shavings, and other hazardous materials) are piled around.	<input type="checkbox"/>
	No condensation or water droplets on the exterior of the machine.	<input type="checkbox"/>
Mechanical parts	The motor installation location meets design and specification requirements.	<input type="checkbox"/>
	The installation of the motor and the connection of shafts and mechanics are reliable.	<input type="checkbox"/>

Check item	Content	Confirmation
	The motor and the machines are available to run.	<input type="checkbox"/>
	Do not run the motor at negative load.  Note: Negative load indicates that the direction of the output torque of the motor is contrary to the motor speed direction.	<input type="checkbox"/>
Wiring parts	All wiring complies with the standard wiring shown in the installation section.	<input type="checkbox"/>
	The external terminal (SON) for servo enabling is set to OFF.	<input type="checkbox"/>
	The cable stress is within the designated range.	<input type="checkbox"/>
	The motor is properly grounded.	<input type="checkbox"/>

9 Common faults

Fault	Possible cause	Solution
Motor not operating when powered on	The power supply cable is disconnected.	Check the wiring and connect it correctly.
	The motor encoder cable is disconnected, and there is a fault in the servo drive.	Check the encoder cable and inspect the output of the servo drive.
	Motor overload prevents startup.	Reduce or remove the load, then restart.
Motor power-on overspeed	The initial angle of the encoder is not recognized.	Reinitialize the encoder initial angle.
Abnormal noise from motor	The motor current loop gain is too high and the power supply phase sequence is reversed.	Contact our technician to adjust the current loop gain value and check the power supply phase sequence.
	Poor installation of the oil seal.	Check the installation status of the oil seal or replace the oil seal.
	Friction occurring in the brake pads.	Please contact your supplier or our local technician for assistance.
	There is a foreign object inside the motor.	
The bearing is damaged.		
Motor operation vibration	Abnormal feedback from the motor encoder.	Check whether the shielding and grounding of the motor encoder cable are in good condition.
	The motor encoder is loose.	Please contact your supplier or our local technician for assistance.
	Current loop gain mismatch.	Contact the technician to adjust the current loop gain value.
Reverse rotation direction	Incorrect motor rotation direction setting.	Check the rotation direction setting of the servo drive motor.
Slow motor acceleration	Incorrect motor acceleration time setting.	Check the acceleration time setting of the servo drive motor.
	Motor overload prevents startup.	Reduce or remove the load.
Motor overheating	The motor is operating under overload conditions.	Reduce the motor load.
	Abnormal motor heat dissipation.	Check that there are no obstructions around the motor.
Brake not responding when powered on	Brake wiring disconnection.	Check the brake connection wires.
	The brake is faulty.	Please contact INVT technical support personnel for assistance.
	Incorrect power supply voltage for the brake.	Check the output voltage of the brake power supply and use a compliant power supply.
Insufficient brake torque	The brake friction pads are worn out.	Replace the motor.

10 Certification categories and standards

10.1 CE certification

Certification	Standard
EMC directive 2014/30/EU	EN 61000-6-4:2019
Low voltage directive (LVD) 2014/35/EU	EN 60034-1:2010

10.2 China energy efficiency label

Certification	Standard
China Energy Efficiency Certification	GB 30253-2024

Your Trusted Industry Automation Solution Provider



Shenzhen INVT Electric Co., Ltd.

Address: INVT Guangming Technology Building, Songbai Road, Matian,
Guangming District, Shenzhen, China

INVT Power Electronics (Suzhou) Co., Ltd.

Address: No. 1 Kunlunshan Road, Science & Technology Town,
Suzhou New District, Jiangsu, China

Website: www.invt.com



INVT mobile website



INVT e-manual



6 6 0 0 1 - 0 1 6 7 1