

# RM Series 50–300kVA Intelligent Modular UPS

## User Manual

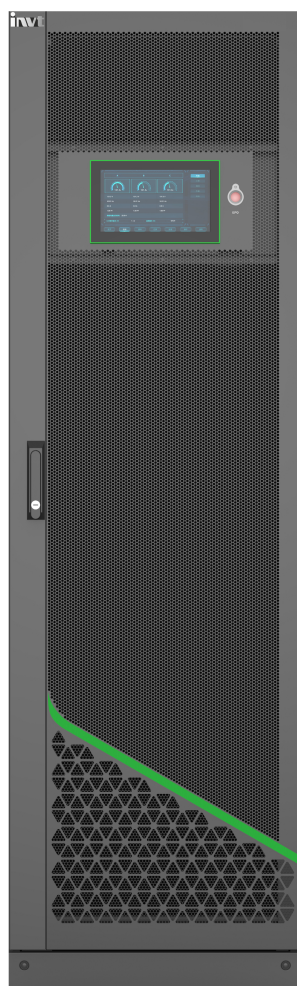

# Preface

## Overview

Thank you for purchasing the INVT RM series 50–300kVA intelligent modular uninterruptible power supply (UPS). (Unless otherwise specified in this manual, "UPS" refers to the RM series 50–300kVA intelligent modular UPS.)

This manual describes the mechanical installation, electrical installation, control panel, commissioning, and maintenance of the RM series 50–300kVA UPS. Read the manual carefully before installing and using the UPS.

## Readers

Personnel with electrical professional knowledge (such as qualified electrical engineers or personnel with equivalent knowledge).

## Change history

The manual is subject to change irregularly due to product version upgrades or other reasons.

Version	Release date	Change description
V1.0	April 2026	First release.

# Contents

<b>1 Safety precautions .....</b>	<b>1</b>
1.1 Safety declaration .....	1
1.2 Safety level definition .....	1
1.3 Personnel requirements .....	1
1.4 Safety guidelines.....	1
<b>2 Product overview .....</b>	<b>4</b>
2.1 Product introduction .....	4
2.2 Product specifications .....	4
2.3 Product weight.....	6
2.4 Product configuration.....	6
2.5 Product structure .....	7
2.5.1 UPS monitoring module .....	7
2.5.2 UPS bypass module .....	8
2.5.3 UPS power module .....	8
2.6 Operating modes .....	8
2.6.1 Normal mode .....	8
2.6.2 Battery mode .....	9
2.6.3 Bypass mode.....	9
2.6.4 Maintenance bypass mode.....	10
2.6.5 ECO mode.....	10
2.6.6 Super ECO mode .....	11
2.6.7 Automatic restart mode.....	11
2.6.8 Frequency converter mode .....	11
2.7 Parallel system .....	12
2.8 Dual bus system .....	13
2.8.1 Function description.....	13
2.8.2 Dual bus system interface.....	13
2.9 Quick startup.....	14
<b>3 Mechanical installation.....</b>	<b>15</b>
3.1 Unpacking inspection .....	15
3.2 Installation preparation .....	15
3.2.1 Installation environment and site .....	15
3.2.2 Installation space .....	16
3.3 Transportation .....	17
3.4 Installation method .....	19
3.4.1 Installing the UPS on the floor.....	19
3.4.2 Installing the UPS against a wall .....	20
<b>4 Electrical installation.....</b>	<b>21</b>
4.1 Converting between single-input and dual-input configurations .....	21
4.2 Battery string installation .....	21
4.2.1 Two-wire battery string installation .....	22
4.3 Cable entry .....	22
4.4 Power cables .....	24
4.4.1 Power cable specifications .....	24
4.4.2 Power cable terminal specifications .....	24
4.4.3 External circuit breaker selection .....	24
4.4.4 Power cable wiring .....	25

4.5 Control cables and communication cables .....	26
4.5.1 Dry contact interfaces.....	26
4.5.2 Communication interfaces .....	30
<b>5 Control panel .....</b>	<b>31</b>
5.1 Cabinet control panel .....	31
5.1.1 Audible alarms .....	31
5.1.2 Control keys .....	31
5.1.3 Touchscreen display area .....	31
5.2 Main menu.....	33
5.2.1 Cabinet.....	33
5.2.2 Module.....	37
5.2.3 Log.....	41
5.2.4 Setting .....	47
5.2.5 Operate.....	49
5.2.6 Scope.....	51
<b>6 Commissioning .....</b>	<b>52</b>
6.1 Starting up the UPS.....	52
6.1.1 Starting up in normal mode .....	52
6.1.2 Starting up in battery mode .....	54
6.2 Mode switching .....	55
6.2.1 From normal mode to battery mode .....	55
6.2.2 From normal mode to bypass mode.....	55
6.2.3 From bypass mode to normal mode.....	55
6.2.4 From normal mode to maintenance bypass mode .....	55
6.2.5 From maintenance bypass mode to normal mode .....	56
6.3 Performing a battery discharge test.....	56
6.4 Shutting down the UPS completely .....	56
6.4.1 With the load powered .....	56
6.4.2 With the load unpowered .....	57
6.5 EPO .....	57
6.6 Resetting after an emergency or abnormal shutdown.....	57
<b>7 Maintenance.....</b>	<b>59</b>
7.1 System maintenance .....	59
7.1.1 Maintaining the power module .....	59
7.1.2 Maintaining the cabinet monitoring module and bypass module .....	61
7.2 Battery string maintenance .....	63
<b>Appendix A Applicable standards.....</b>	<b>64</b>
<b>Appendix B Dimensions.....</b>	<b>65</b>

# 1 Safety precautions





## 1.1 Safety declaration

Read this manual carefully and follow all safety precautions before handling, installing, operating, and maintaining the product. Otherwise, equipment damage, physical injury, or death may be caused.

**Note:** INVT shall not be liable for any equipment damage, physical injury, or death caused by failure to follow the safety precautions.

## 1.2 Safety level definition





To ensure personal safety and avoid property damage, pay attention to the safety symbols and warnings in the manual.

Symbol	Name	Description
	Danger	Severe personal injury or even death can result if related requirements are not followed.
	Warning	Personal injury or equipment damage can result if related requirements are not followed.
	Caution	Moderate personal injury can result if related requirements are not followed.
	Electrostatic discharge	Equipment damage can result if related requirements are not followed.
	Hot surface	You may get burnt if related requirements are not followed.



## 1.3 Personnel requirements

**Trained and qualified professionals:** People operating the equipment must have received professional electrical and safety training and obtained the certificates, and must be familiar with all steps and requirements of equipment installing, commissioning, operating, and maintaining, and capable of preventing any emergencies.

## 1.4 Safety guidelines



General principles	
	<ul style="list-style-type: none"> <li>Only trained and qualified professionals are allowed to carry out related operations.</li> <li>Do not perform wiring, inspection, or component replacement when the power supply is applied. Before performing these operations, ensure the UPS is completely powered off and wait for at least 10 minutes.</li> </ul>
	<ul style="list-style-type: none"> <li>Pay attention to all warning labels and follow the instructions during operation.</li> </ul>
	<ul style="list-style-type: none"> <li>The heat sink base may become hot during UPS operation. Do not touch. Otherwise, you may get burnt.</li> </ul>
	<ul style="list-style-type: none"> <li>The electrical parts and components inside the UPS are electrostatic sensitive. Take measures to prevent electrostatic discharge when performing related operations.</li> </ul>

<b>Handling</b>	
	<ul style="list-style-type: none"> <li>● Select appropriate tools for handling to avoid damage to the UPS, and take protective measures like wearing safety shoes and protective clothing to avoid physical injury or death.</li> <li>● Protect the UPS against physical shock or vibration during handling and installation.</li> </ul>

<b>Installation</b>	
	<ul style="list-style-type: none"> <li>● Do not operate the UPS with wet hands or touch live parts with wet objects, as this poses a risk of electric shock.</li> <li>● In case of fire, use a dry powder fire extinguisher to extinguish the fire properly. Using a liquid fire extinguisher may result in the risk of electric shock.</li> </ul>
	<ul style="list-style-type: none"> <li>● Do not install the UPS on combustible materials. In addition, prevent the UPS from contacting or adhering to combustible materials.</li> <li>● Connect the optional braking parts (such as braking resistors, braking units, or regenerative units) according to the wiring diagrams.</li> <li>● Do not operate the UPS if it is damaged or incomplete.</li> <li>● Do not install the UPS near heat sources or in the vicinity of electric heaters or similar devices.</li> </ul>
	<ul style="list-style-type: none"> <li>● Use the UPS in proper environments. (For details, see chapter 3 Mechanical installation and chapter 4 Electrical installation.)</li> <li>● Prevent the screws, cables and other conductive parts from falling into the UPS.</li> </ul>

<b>Commissioning and operation</b>	
	<ul style="list-style-type: none"> <li>● Before connecting the input power (including AC mains and battery), ensure proper grounding and verify that all wiring and battery polarity are correct. The grounding of the equipment must comply with local electrical regulations.</li> <li>● When the UPS needs to be relocated or rewired, in addition to the above precautions, ensure that:                         <ul style="list-style-type: none"> <li>✧ All input power supplies have been disconnected, including the main power and control power.</li> <li>✧ The UPS has been fully shut down for more than 10 minutes, and the measured output voltage is below 36V.</li> </ul> </li> </ul>

<b>Maintenance</b>	
	<ul style="list-style-type: none"> <li>● All internal maintenance of the equipment must be performed with appropriate tools and carried out by trained and qualified personnel. Components located behind protective covers that require tools to open are not user-serviceable.</li> <li>● The UPS fully complies with safety requirements for equipment in the operation area. It contains hazardous voltages, which are not accessible to non-service personnel. Access to components carrying hazardous voltages is only possible after opening protective covers with tools, which has minimized the risk of contact with high voltage. There is no danger when the equipment is operated in accordance with general safety standards and the procedures recommended in this manual.</li> <li>● During maintenance and component replacement, take measures to prevent screws, cables, and other conductive materials from falling into the UPS.</li> </ul>

Battery safety	
	<ul style="list-style-type: none"> <li>● Use appropriate tools or keys when servicing and maintaining all batteries. Only trained and qualified personnel can carry out these tasks.</li> <li>● Handle batteries with special care. Be aware that after battery connection, the battery terminal voltage may exceed 400VDC, posing a fatal risk upon contact.</li> <li>● Follow the battery manufacturer's safety instructions at all times when using the battery string or working nearby. Pay special attention to recommendations regarding local environmental conditions, and comply with relevant requirements for providing protective clothing, first aid equipment, and fire-fighting equipment.</li> <li>● The battery life decreases as the ambient temperature increases. Replace batteries regularly to ensure proper UPS operation and sufficient backup time.</li> <li>● Replace batteries only with those of the same type, model, and quantity.</li> <li>● When connecting batteries, the terminal voltage may exceed 400VDC, which is a hazardous voltage level. To avoid electric shock or personal injury during battery replacement, observe the following precautions:                         <ul style="list-style-type: none"> <li>✧ Wear eye protection to prevent injury from accidental arcs.</li> <li>✧ Do not wear watches, rings, or other metal objects.</li> <li>✧ Use insulated tools.</li> <li>✧ Wear protective clothing and rubber gloves.</li> <li>✧ Do not place metal tools or similar metal parts on the batteries.</li> <li>✧ Before disconnecting battery terminals, make sure all loads connected to the batteries are disconnected.</li> <li>✧ Do not expose batteries to fire, as this may cause an explosion and endanger personal safety.</li> <li>✧ Do not short-circuit the positive and negative terminals of the battery, as this may result in electric shock or fire.</li> <li>✧ If skin comes into contact with electrolyte, rinse immediately with water.</li> </ul> </li> </ul>
Disposal	
	<ul style="list-style-type: none"> <li>● The UPS contains heavy metals. Dispose of an end-of-life UPS as industrial waste.</li> </ul>

## 2 Product overview

### 2.1 Product introduction

The RM series 50–300kVA intelligent modular UPS features an online double-conversion and three-phase input and three-phase output design. Based on fully digital DSP control, it provides a stable and uninterruptible power for critical loads. It eliminates mains power disturbances such as surges, voltage spikes and sags, line noise, and frequency deviation, while providing efficient, high-density power protection. With its robust power capacity, it is an ideal solution for small- and medium-sized data centers, telecom base stations, financial institutions, and other similar facilities.

### 2.2 Product specifications

	Item	Specifications
Input rectifier electrical specifications	Input wiring	Three-phase + Neutral + PE
	Rated AC input voltage	380/400/415VAC (3-phase and sharing neutral with the bypass input)
	Rated frequency	50/60Hz
	Input voltage range	304–478VAC (line voltage) at full load 228–304VAC (line voltage), with linear derating from 100% to 75% load
	Input frequency range	40–70Hz
	Input power factor	>0.99 @ >75% rated load
	Total harmonic distortion of current (THDi)	<3%
Intermediate DC circuit electrical specifications	Battery bus voltage	Rated: 360–600VDC
	Number of lead-acid batteries	30–50 (12V each; 30 batteries: derate to 90%; 32–50 batteries: no derating)
	Float charge voltage	2.25V/cell (setting range: 2.10–2.35V/cell) Constant current and constant voltage charging mode
	Boost voltage	2.28V/cell (setting range: 2.10–2.35V/cell) Constant current and constant voltage charging mode
	Float charge temperature compensation	0.0mV/°C (setting range: 0.0–5.0mV/°C)
	Boost charge temperature compensation	0.0mV/°C (setting range: 0.0–5.0mV/°C)
	Ripple voltage	≤1%
	Ripple current	≤5%
	End of discharge (EOD) voltage	1.65V/cell (setting range: 1.60–1.85V/cell) @0.6C discharge current
		1.75V/cell (setting range: 1.65–1.90V/cell) @0.15C discharge current  <b>Note:</b> EOD varies linearly within the setting ranges according to discharge current.

Item		Specifications
	Power module charge current limit	45A (setting range: 1–45A; 50% rated output power corresponds to a maximum charge current of 45A per module)
	<p><b>Note:</b> This UPS supports lithium-ion batteries. Contact technical support for details regarding relevant applications.</p>	
Inverter output electrical specifications	Rated power	50–300kVA
	Rated output voltage	380/400/415VAC (three-phase, four-wire, and sharing neutral with the bypass)
	Rated output frequency	50/60Hz
	Frequency accuracy	50/60±0.01Hz
	Voltage accuracy	±1.0% (0–100% linear load)
	Inverter overload	110%: 1 hour; 125%: 10 minutes 150%: 1 minute; > 150%: 200ms
	Synchronization window	Adjustable, ±0.5–±5Hz, ±3Hz by default
	Slew rate	Adjustable, 0.5–3Hz/s, 0.5Hz/s by default
	Output power factor	1
	Output dynamic response	<5% (0%–100%–0% step load)
	Dynamic recovery time	<20ms (0%–100%–0% step load)
	Total harmonic distortion of voltage (THDu)	<1%, 100% linear load; <4%, 100% non-linear load
Bypass mains input electrical specifications	Rated power	50–300kVA
	Rated AC voltage	380/400/415VAC (three-phase, four-wire, sharing neutral with the rectifier input and providing neutral reference to the output)
	Rated current (I <sub>n</sub> )	75.8A × n <b>Note:</b> n is the number of power modules.
	Overload	110%: continuous operation 110%–125%: 10 minutes 125%–150%: 1 minute >150%, 200ms
	Rated neutral current	1.7 × I <sub>n</sub>
	Frequency	50/60Hz
	Transfer time (between bypass and inverter)	0ms
	Bypass voltage range	Upper limit: +10%, +15%, +20%; default: +15% Lower limit: -10%, -15%, -30%, -40%; default: -20%
	Bypass frequency limit	Selectable: ±1Hz, ±3Hz, ±5Hz
Efficiency	Overall efficiency	Normal mode (double conversion): ≥97% ECO mode: ≥99%
	Battery discharge efficiency	Battery at nominal voltage 480VDC and full-rated linear load Battery mode: ≥95.5%
	Heat losses (rated 300kVA)	Rated full-load loss in normal mode: 10.81kW
		Rated no-load loss in normal mode: 1.44kW Rated full-load loss in ECO mode: 2.7kW

Item		Specifications
System display and interface	Display	LED indicators + LCD touchscreen
	Interface	Standard: CAN, RS485, USB, dry contact, LBS, parallel card (excluding parallel cable) Optional: RS485 expansion card, SNMP card, intelligent AS400 card
Environment specifications	Noise level (at 1m)	75dB at 100% load, 65dB at 45% load
	Altitude	≤ 1000m Derate 1% for every increase of 100m from 1000m to 2000m
	Relative humidity	0–95%RH, no condensation
	Operating temperature	0–40°C; battery life is halved for every 10°C increase above 20°C
	UPS storage and transport temperature	-40°C–+70°C
	Recommended battery storage temperature	-20–+30°C (20°C is optimal)
Mechanical specifications	Color	Black
	IP rating (IEC 60529)	IP20

### 2.3 Product weight

Table 2-1 Product weight

Model	Net weight (kg)
300kVA cabinet (including monitoring module and bypass module)	240
50kVA power module (single module)	32

### 2.4 Product configuration

The RM series 50–300kVA intelligent modular UPS system mainly consists of the main power conversion circuit, static bypass switch, mains input switch, bypass input switch, maintenance bypass switch, output switch, and external battery string. The mains input switch, bypass input switch (for dual-input configuration), and output switch are optional. The configuration is shown in Figure 2-1. The area inside the dashed box represents the UPS cabinet (maintenance bypass switch included as standard).

Figure 2-1 Product schematic diagram

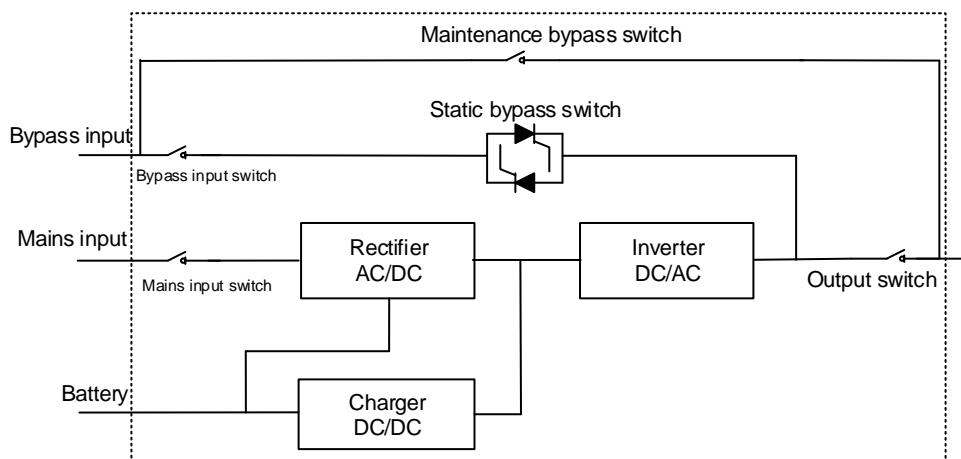

The main power conversion circuit consists of multiple UPS power modules connected in parallel, including the rectifier (AC/DC), inverter (DC/AC), and charger (DC/DC). The static bypass switch is composed of anti-parallel SCRs, allowing the mains power to supply the load directly through the switch. For internal UPS maintenance, the maintenance bypass switch can be used to ensure an uninterrupted power supply to the load. When the mains power fails, the external battery string supplies power to the rectifier for voltage boosting, after which the inverter delivers a pure sine wave AC to the load.

## 2.5 Product structure

The product structure is shown in Figure 2-2.

Figure 2-2 Product structure

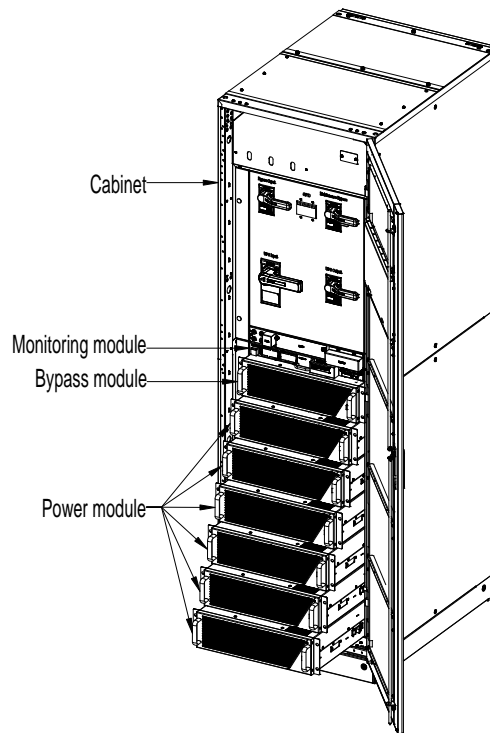

Table 2-2 UPS configuration

Position	Component	Quantity (piece)	Remarks
300kVA cabinet	Monitoring module	1	Standard configuration
	Bypass module	1	Standard configuration
50kVA power module	Power module	1–6	-

### 2.5.1 UPS monitoring module

The UPS monitoring module primarily consists of a monitoring controller, enabling the monitoring and management of the UPS. The module structure is shown in Figure 2-3.

Figure 2-3 Monitoring module

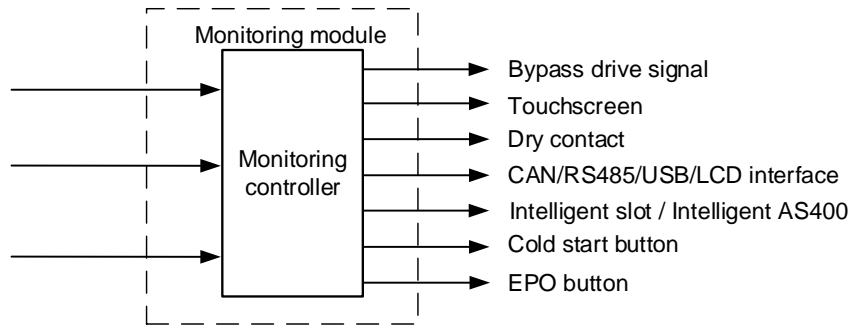

### 2.5.2 UPS bypass module

The UPS bypass module is mainly composed of a bypass SCR and a drive controller to realize the UPS bypass mode. Its structure is shown in Figure 2-4.

Figure 2-4 Bypass module

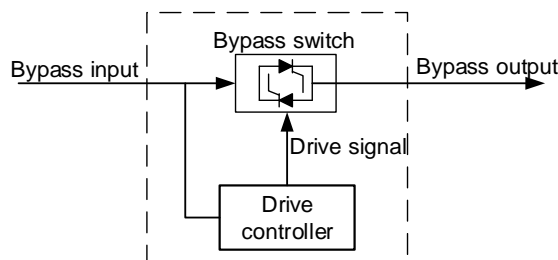

### 2.5.3 UPS power module

The UPS power module mainly consists of a rectifier, an inverter, and a charger. The rectifier converts AC input into DC, the inverter converts DC into AC output, and the charger charges external batteries. The structure of the power module is shown in Figure 2-5.

Figure 2-5 Power module

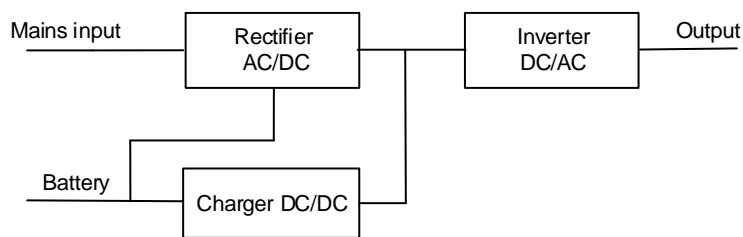

## 2.6 Operating modes

The UPS system adopts an online double-conversion design. It can operate in various modes depending on the operating conditions, including normal mode, battery mode, bypass mode, maintenance bypass mode, ECO mode, super ECO mode, automatic restart mode, and frequency converter mode.

**Note:** The dark lines indicate the paths involved in the operating mode, and the arrows show the direction of power flow.

### 2.6.1 Normal mode

In normal mode, the UPS converts the AC input to DC voltage through the rectifier. The DC voltage is then boosted to the bus voltage. When the system is connected to an external battery, part of the DC power is used to charge the battery via the charger, while the other part is converted by the inverter to supply high-quality

AC power to the load. The schematic diagram of normal mode is shown in Figure 2-6.

Figure 2-6 Schematic diagram of normal mode

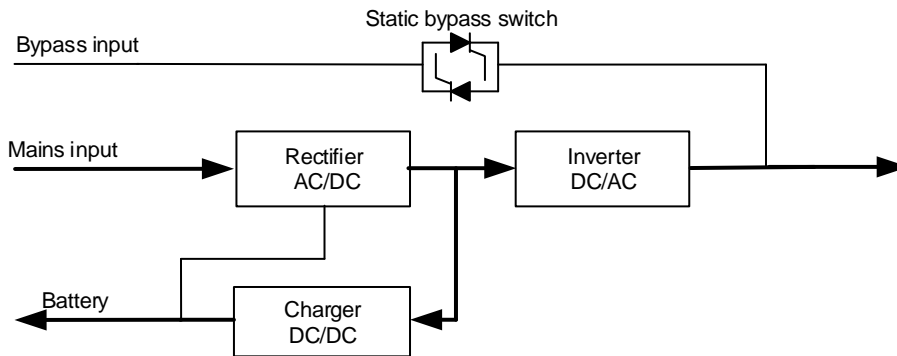

### 2.6.2 Battery mode

The operating mode in which the battery supplies AC power to the load through the inverter is called battery mode. When the mains power fails, the UPS automatically switches to battery mode to ensure an uninterrupted power supply to the load. When the mains power is restored, the UPS transfers back to normal mode without interruption. The schematic diagram of battery mode is shown in Figure 2-7.

Figure 2-7 Schematic diagram of battery mode

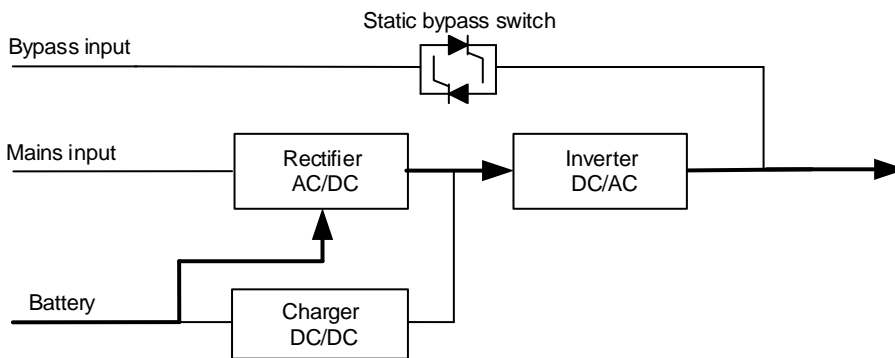

**Note:** The UPS features a battery cold start function, allowing it to start directly from the battery (if charged) when the mains power is unavailable. This enables the UPS to operate solely on battery power, expanding its range of applications. For details, refer to section 6.1.2 Starting up in battery mode.

### 2.6.3 Bypass mode

After the system is powered on, if the inverter is not activated or is manually turned off, the load is powered through the bypass. During normal operation, if the UPS monitoring module detects an overtemperature, overload, or any other fault in the power module that causes the inverter to shut down, the system will automatically switch to bypass mode. In this condition, the input power is supplied directly to the load through the static bypass switch. In bypass mode, the power supplied to the load is not protected by the UPS, making it susceptible to conditions such as power outages, voltage waveform distortions, and frequency abnormalities. The schematic diagram of bypass mode is shown in Figure 2-8.

Figure 2-8 Schematic diagram of bypass mode

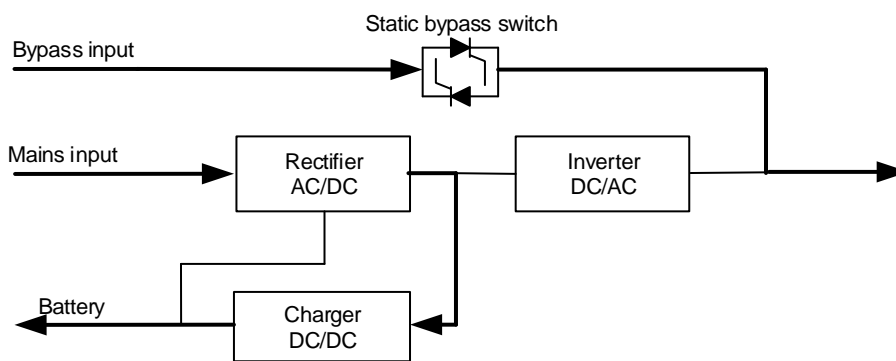

**Note:** In bypass mode, if mains power failure occurs or the mains voltage goes out of range, the UPS will shut down, and the output will be interrupted.

### 2.6.4 Maintenance bypass mode

Before performing maintenance or repairs on the UPS system or batteries, open the input, output, bypass, and battery switches. Proceed as follows:

- Step 1 Transfer to bypass mode.
- Step 2 Manually close the maintenance bypass switch.
- Step 3 Open the input, output, and bypass switches.
- Step 4 Open the external battery switch.

The input power is supplied directly to the load via the maintenance bypass, enabling maintenance without power interruption to the load. The operating principle is shown in Figure 2-9.

Figure 2-9 Schematic diagram of maintenance bypass mode

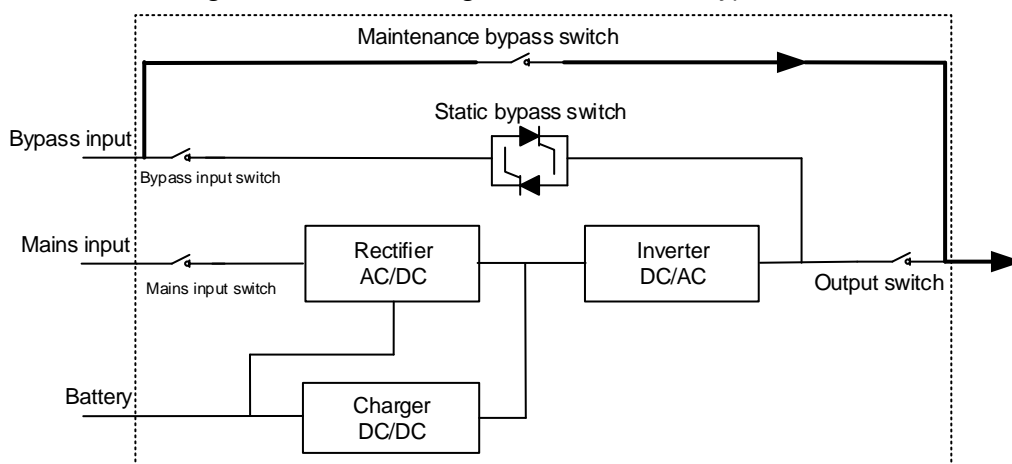

**Note:** After the UPS switches to maintenance bypass mode, the mains power input is disconnected, and the UPS stops operating. Before performing any maintenance or repairs on the UPS, ensure that the output circuit breaker is open and external battery power is disconnected; otherwise, personal injury or equipment damage may occur.

### 2.6.5 ECO mode

ECO mode refers to the UPS economy mode, which can be set via the control panel or software. When the system is set to ECO mode and the bypass input voltage is within the ECO input voltage range, the load is supplied directly through the static bypass switch while the rectifier and inverter remain on standby. When the bypass input voltage falls outside the ECO input voltage range, the load supply switches from bypass

power to inverter power, operating in normal mode. In ECO mode, the system achieves higher efficiency. The schematic diagram is shown in Figure 2-10.

Figure 2-10 Schematic diagram of ECO mode

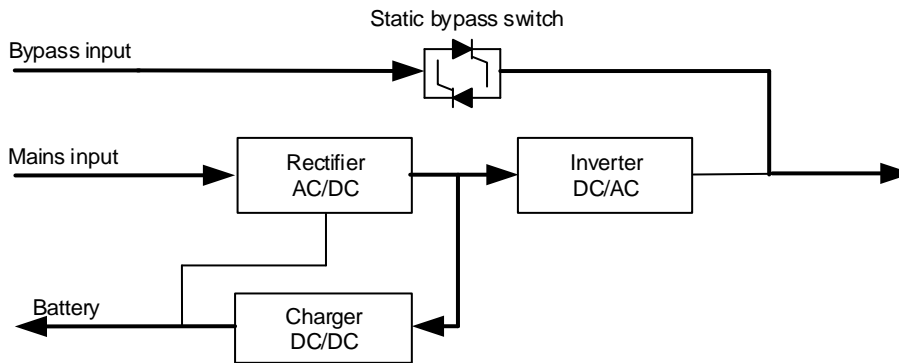

**Note:**

- In ECO mode, if the output is not overloaded but a bypass power failure or abnormal bypass voltage occurs, the UPS will switch to normal mode. However, if the output is overloaded under these conditions, the UPS will not switch to normal mode and will instead disable the bypass.
- In ECO mode, the UPS efficiency can reach up to 99%.

### 2.6.6 Super ECO mode

Super ECO mode is an enhanced UPS economy mode that can be configured via the control panel. Building upon the standard ECO mode, it alters the inverter's operating state to perform active filtering for the bypass output, thereby improving the bypass output's power quality. The schematic diagram is shown in Figure 2-11.

Figure 2-11 Schematic diagram of super ECO mode

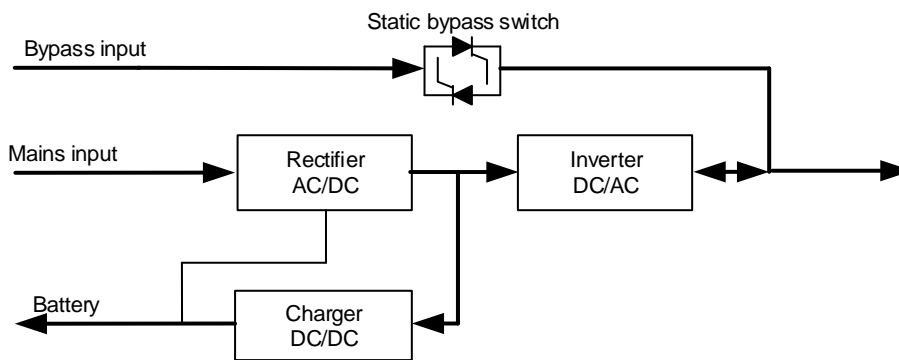

**Note:** This mode is optional. For specific details, refer to the *Super ECO Mode Guide*.

### 2.6.7 Automatic restart mode

The UPS provides an automatic restart function. When mains power is lost for an extended period and the battery discharges to the EOD voltage, causing the inverter to shut down, the UPS will automatically restart once mains power is restored. This function can be configured by trained and qualified personnel.

### 2.6.8 Frequency converter mode

The UPS can be set to frequency converter mode to provide a stable output frequency of either 50Hz or 60Hz, with an input frequency range of 40Hz to 70Hz. In this mode, the bypass mode is unavailable. The use of batteries is optional, depending on whether battery mode is required.

## 2.7 Parallel system

Warning	
	<ul style="list-style-type: none"> <li>Each unit in the parallel system requires individual configuration via the monitoring software to ensure normal operation. The configuration must be performed by professional technicians.</li> </ul>

Up to five UPS cabinets of the same capacity can be connected in parallel. The parallel configuration is shown in Figure 2-12.

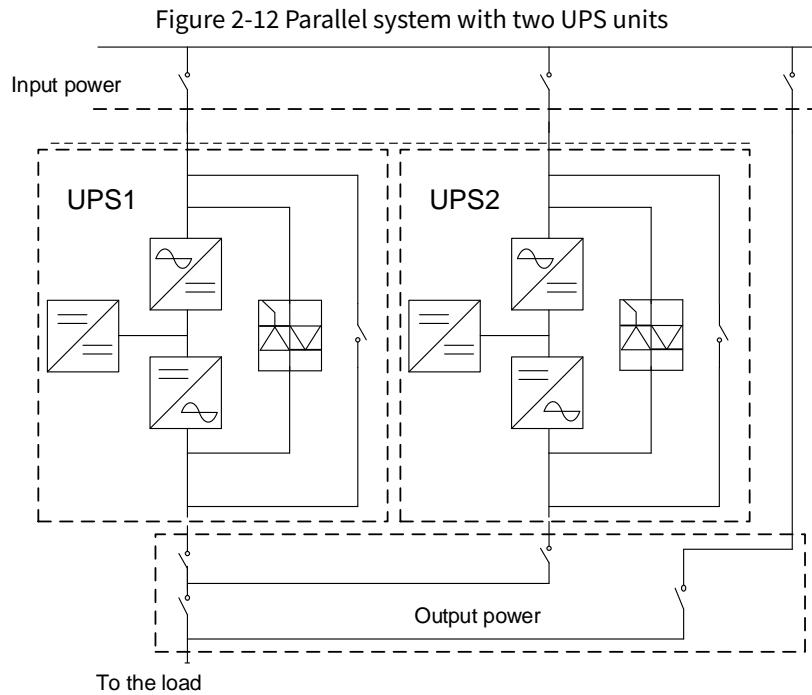

The parallel wiring terminals are located on the front of the cabinet. They can be accessed by opening the cabinet door and removing the terminal cover, as shown in Figure 2-13.

Figure 2-13 Location of parallel terminals

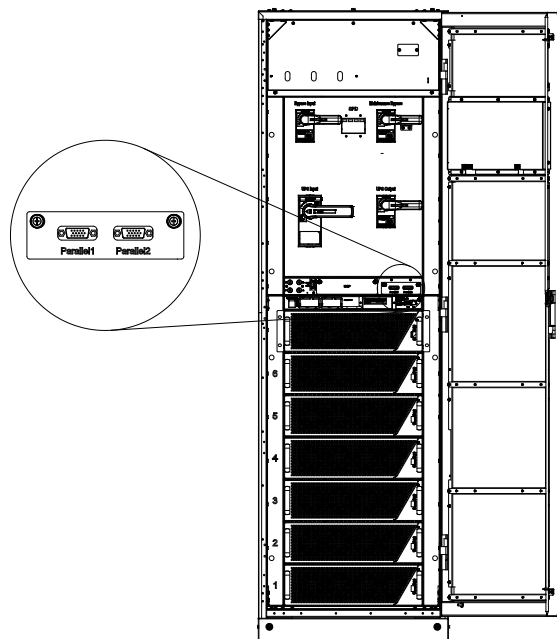

**Note:** The control cables must be connected in a ring for parallel operation, as shown in Figure 2-14.

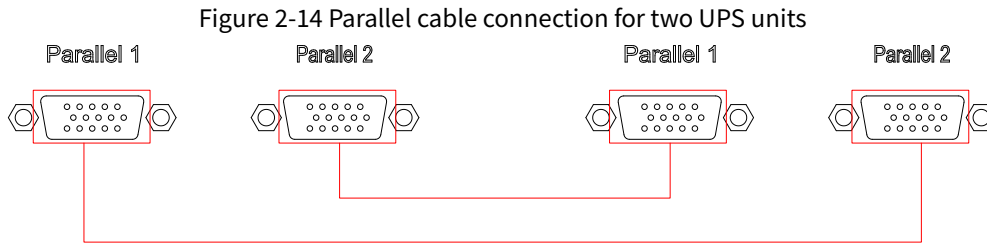

## 2.8 Dual bus system

<b>Warning</b>	
	<ul style="list-style-type: none"> <li>To set up the dual bus system, use the monitoring software to configure each unit. This configuration must be carried out by professional technicians.</li> <li>The dual bus system interface voltage must match the UPS output voltage. All connecting cables must be rated for 600V or higher.</li> </ul>

### 2.8.1 Function description

The dual bus system consists of two independent UPS systems. Each UPS system can consist of one or more UPS units operating in parallel. This architecture offers high reliability and is suitable for loads with multiple input terminals. To maintain phase synchronization between two UPS systems and achieve seamless transfer, a Load Bus Synchronization (LBS) unit and a Static Transfer Switch (STS) must be installed between the two systems.

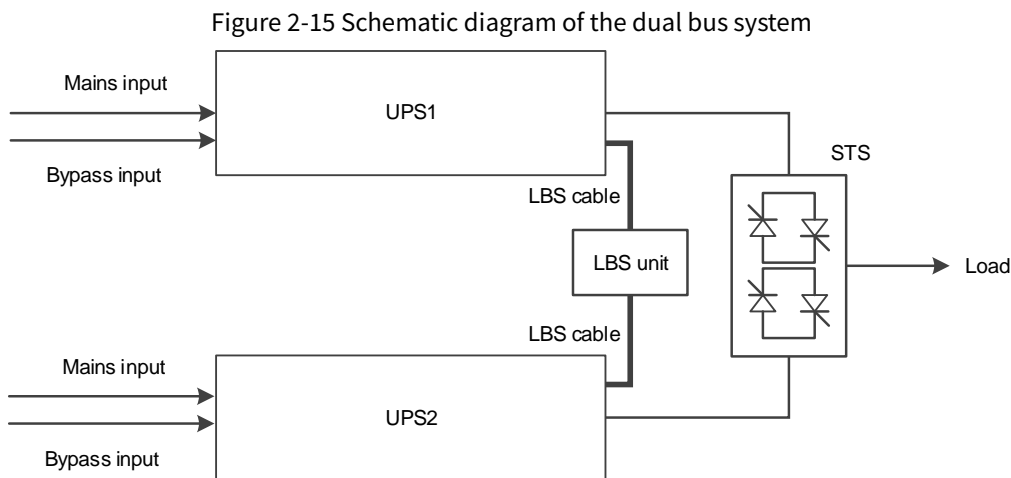

### 2.8.2 Dual bus system interface

The location of the dual bus system signal interface is shown in Figure 2-16. The connections from the UPS1 and UPS2 LBS interfaces to the LBS unit are shown in Figure 2-17.

Figure 2-16 UPS system interface location

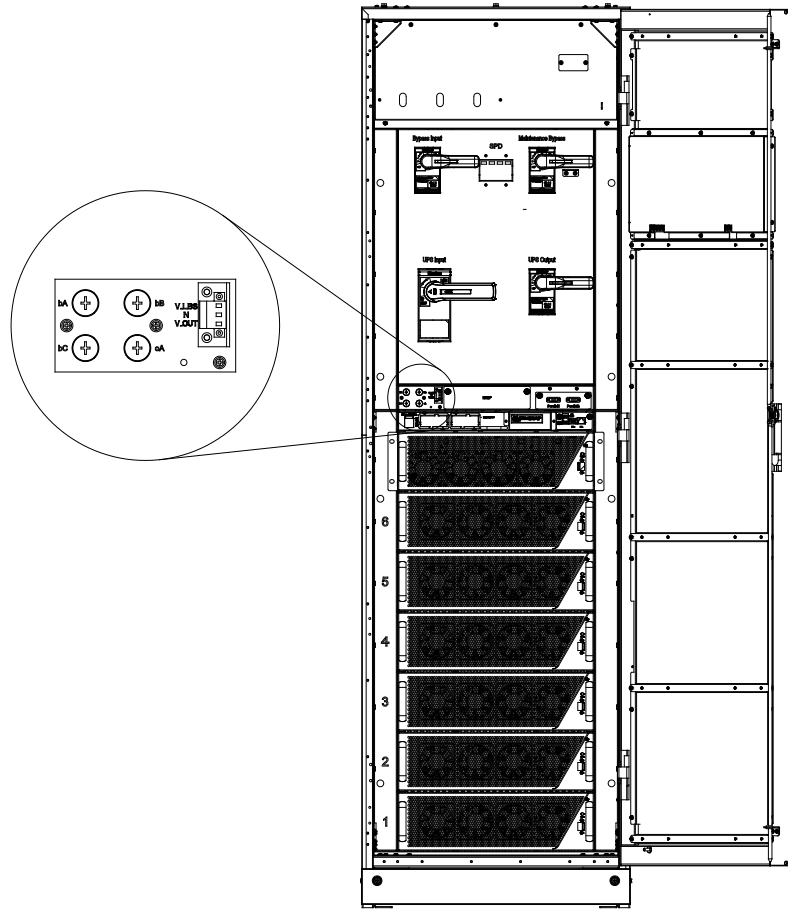
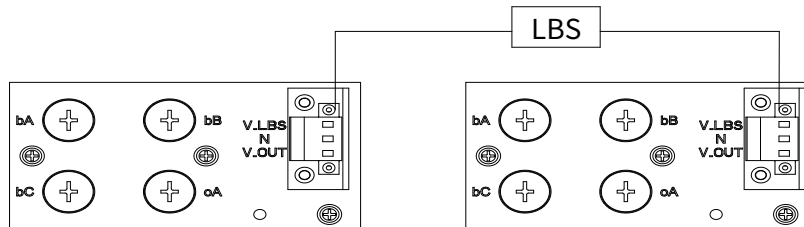

Figure 2-17 Connection between UPS LBS interface and LBS unit



## 2.9 Quick startup

Task	Reference
1. Unpacking inspection	See section 3.1 Unpacking inspection.
2. Installation environment and site inspection	See section 3.2 Installation preparation.
3. Floor installation	See section 3.4 Installation method.
4. Wiring	See section 4 Electrical installation.
5. Commissioning	See section 6 Commissioning.

# 3 Mechanical installation

## 3.1 Unpacking inspection

Upon receiving the product, perform the following inspections to ensure safe operation.

- **Checking the packaging**

Before unpacking, check whether the outer packaging is intact: whether the package is damaged, wet, damp, or deformed. After unpacking, check the interior of the box for any abnormalities such as water stains.

- **Checking the UPS and components**



After unpacking, inspect the UPS exterior for transportation damage. If any damage is found, notify the shipping company immediately.

Check the supplied accessories against the packing list to verify that all required accessories are included and that their models are correct. If any items are missing or incorrect, record the issue on site and contact the local INVT office.



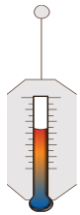

## 3.2 Installation preparation

### 3.2.1 Installation environment and site

- **Environmental requirements**

Environment	Requirement	
Temperature		<ul style="list-style-type: none"> <li>● The optimal battery operating temperature is 20°C–30°C.</li> <li>● Operating in temperatures above 30°C will reduce battery service life, while operating below 20°C will reduce battery backup time.</li> <li>● No sudden temperature change.</li> <li>● When the UPS is installed in an enclosed space, such as a control cabinet, use a cooling fan or air conditioner to control the temperature if necessary.</li> <li>● When the ambient temperature is low, if the UPS has been powered off for a long period, install an external heating device before restart to eliminate internal frost; otherwise, the UPS may be damaged.</li> <li>● The UPS is designed for indoor installation and uses forced-air cooling with internal fans. Ensure sufficient clearance around the cabinet for proper ventilation and heat dissipation.</li> <li>● Batteries produce small amounts of hydrogen and oxygen near the end of charging. Adequate ventilation must be provided in accordance with EN 50272-2001.</li> </ul>
Humidity		<ul style="list-style-type: none"> <li>● Less than 95%RH, no condensation</li> </ul>

■ **Site requirements**

Site	Requirement	
Indoor		Free from sources of electromagnetic radiation and direct sunlight. <b>Note:</b> The unit must be installed in a clean and well-ventilated environment based on the housing IP rating.
		Free from foreign matter such as oil mist, metal powder, conductive dust, and water. <b>Note:</b> Do not install the UPS in environments containing conductive metallic dust.
		Free from radioactive, corrosive, hazardous, flammable, or explosive substances. <b>Note:</b> Do not install the UPS on combustible surfaces.
		Low salt content.

**Note:** As the UPS uses external batteries, install a protective device (such as a DC circuit breaker) as close to the batteries as possible. Keep the connections between the UPS and batteries as short as possible.

### 3.2.2 Installation space

Ensure that the floor or installation platform can support the combined weight of the UPS, batteries, and battery racks. The site must be free from vibration and shock, with a vertical inclination not exceeding 5°.

If immediate installation is not required, store the UPS indoors in an environment free from high humidity and extreme temperatures. Batteries should be stored in a dry, cool, and well-ventilated environment, with an optimal storage temperature of 20°C to 25°C. Batteries should not be stored for more than 3 months; supplementary charging is required for longer storage periods.

Reserve at least 800mm in front of the cabinet to allow replacement of power modules, and at least 500mm behind the cabinet for airflow and heat dissipation. The required clearance around the cabinet is shown in Figure 3-1.

Figure 3-1 Cabinet clearance requirements (unit: mm)

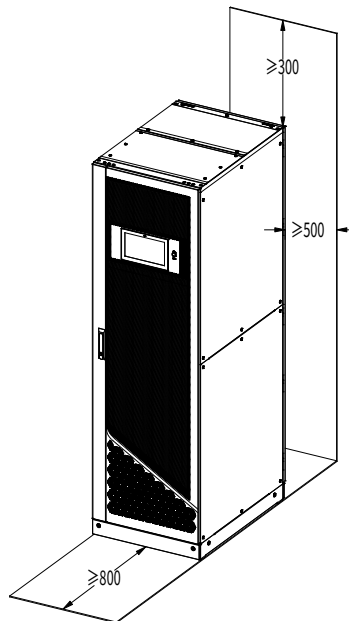

### 3.3 Transportation

Follow these steps for handling and unpacking the cabinet:

- Step 1 Check that the UPS packaging is intact. In case of any transportation damage, immediately notify the shipping company.
- Step 2 Use a forklift to move the equipment to the designated location.

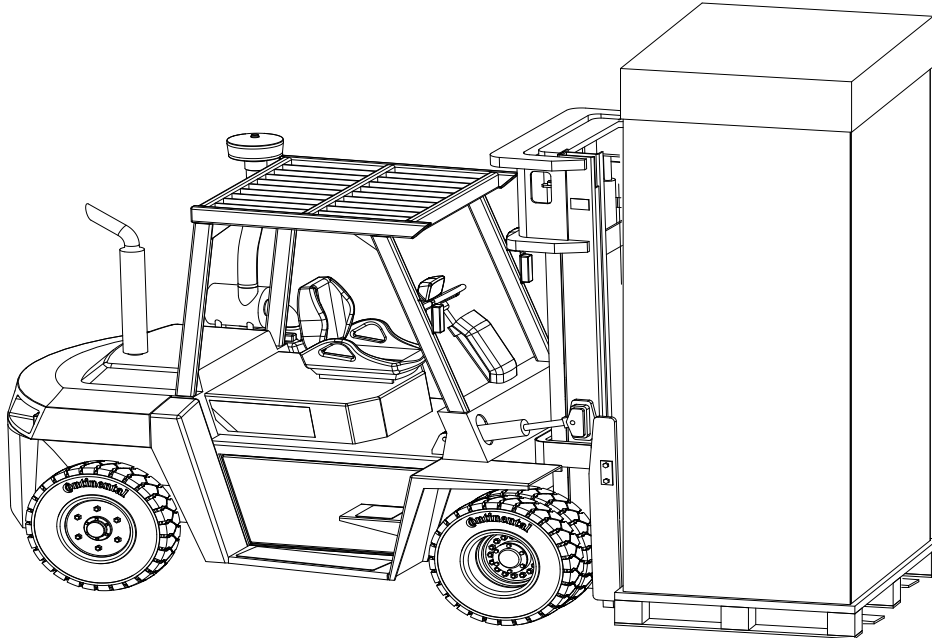

- Step 3 Open the top cover and remove the carton.

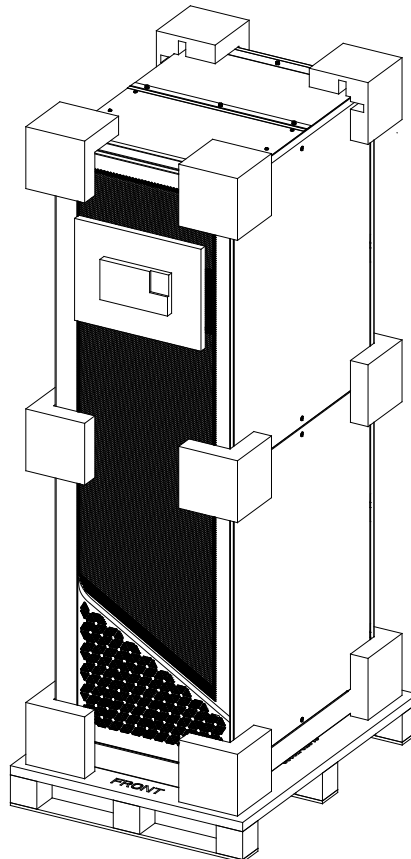

Step 4 Remove the protective plastic bag and foam padding.

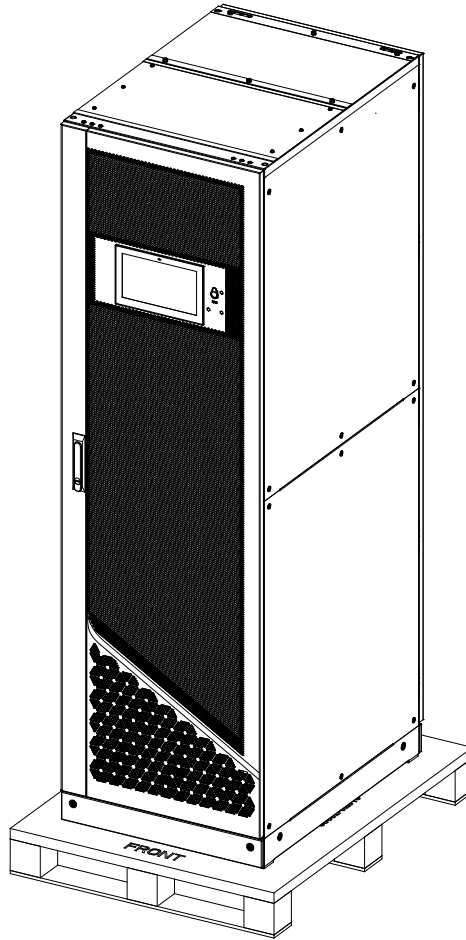

Step 5 After verifying the equipment is intact, remove the screws securing the cabinet to the wooden pallet.

**Note:**

- Do not use excessive force when unpacking the equipment to avoid damage.
- After unpacking, dispose of all packaging materials in accordance with local environmental protection requirements.

## 3.4 Installation method

### 3.4.1 Installing the UPS on the floor

For a standalone installation, the weight of the UPS cabinet is supported by four fixing brackets at the bottom. This method is typically used to provide long-term support once the cabinet is fixed in its final position. The fixing bracket is shown in Figure 3-2.

Figure 3-2 Cabinet bottom view (unit: mm)

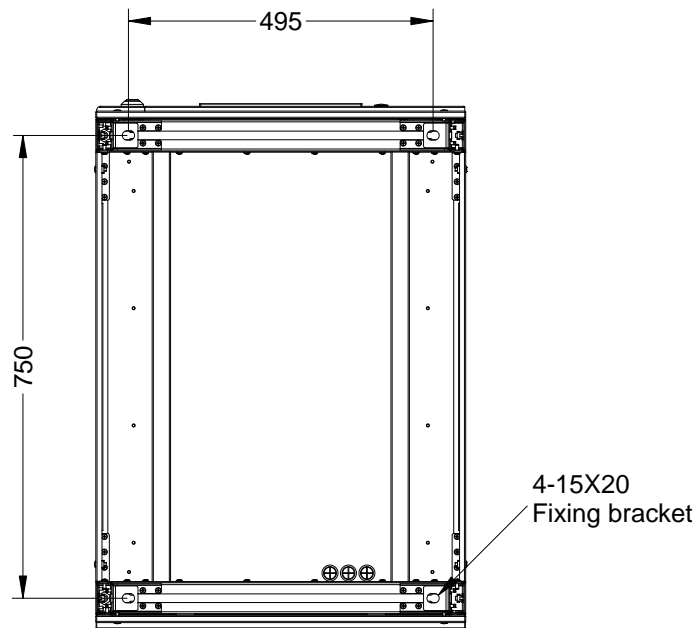

To install a standalone UPS cabinet, follow these steps:

- Step 1 Verify that the cabinet support feet are intact and the floor is level.
- Step 2 Use a forklift to move the cabinet to its location. Then, the cabinet should be supported by its fixing brackets.
- Step 3 Verify that all four fixing brackets are secure and properly aligned to ensure the cabinet is stable.
- Step 4 The installation is complete.

**Note:** If the floor load capacity is insufficient, take measures to distribute the cabinet weight over a larger support area, such as laying a large steel plate or enlarging the support frame area.

### 3.4.2 Installing the UPS against a wall

For standalone installation, the UPS cabinet can be installed against a wall by mounting the top air exhaust kit on the cabinet after completing the floor installation described in section 3.4.1 Installing the UPS on the floor. The top air exhaust kit is shown in Figure 3-3.

Figure 3-3 Top air exhaust kit

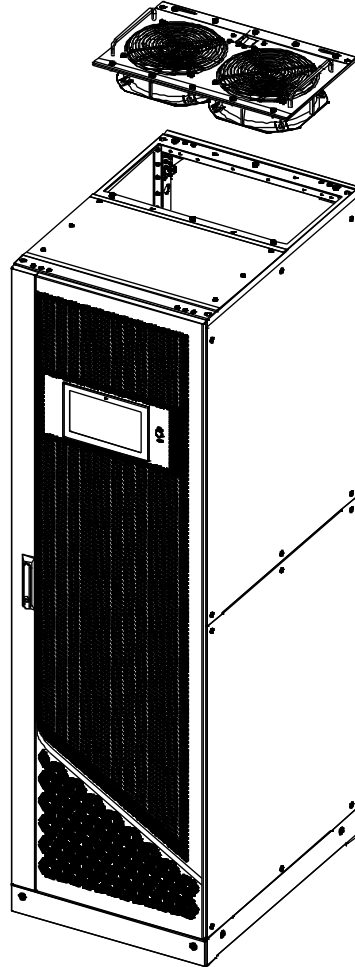

**Note:** Installation against a wall is only possible if the top air exhaust kit is installed. In other cases, follow the spacing requirements in section 3.2.2 Installation space.

# 4 Electrical installation

## 4.1 Converting between single-input and dual-input configurations

By default, the UPS cabinet is delivered in a dual input (separate mains and bypass input sources) configuration.

To convert the UPS cabinet from dual input to single input (shared input), the optional shared input kit is required. Install the three shorting copper bars to connect the mains and bypass inputs (Phases A, B, and C), as shown in the following figure.

Figure 4-1 Shared input kit

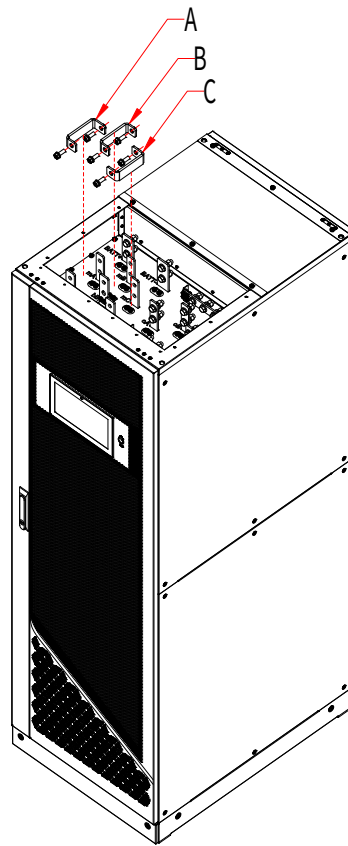

## 4.2 Battery string installation

Three cables are routed from the battery string to connect with the UPS system: the positive (BAT+), the negative (BAT-), and the neutral (N). The battery neutral, which serves as a reference potential, is connected at the midpoint between BAT+ and BAT-. The connection diagram is shown below.

Figure 4-2 Battery string connection (example using 40 batteries)

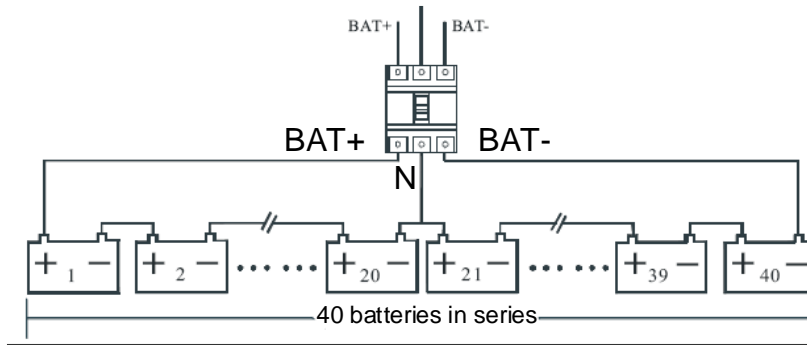

**Note:** Batteries carry lethal voltage. Follow chapter 1 Safety precautions during installation. Ensure that the polarity is correct between the battery string and its external switch, as well as between the external switch and the UPS system. Do not reverse the connections.

### 4.2.1 Two-wire battery string installation

In a two-wire battery string, only the positive (BAT+) and negative (BAT-) are connected to the UPS. The detailed wiring is shown in Figure 4-3.

Figure 4-3 Two-wire battery string wiring (example using 40 batteries)

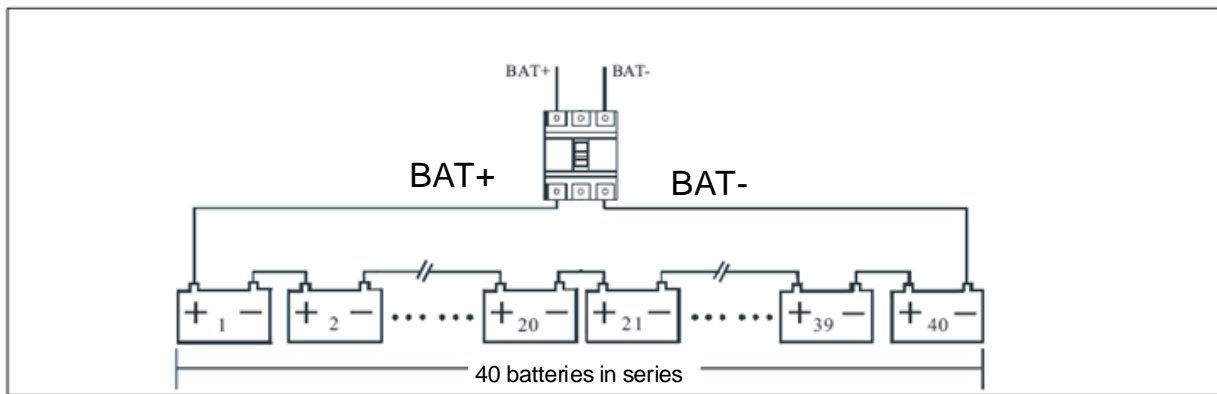

**Note:** The two-wire battery string configuration is optional. See the *Two-Wire Battery String Application Guide* for detailed instructions.

### 4.3 Cable entry

The cabinet supports top cable entry and exit, as shown in Figure 4-4.

Figure 4-4 Top entry

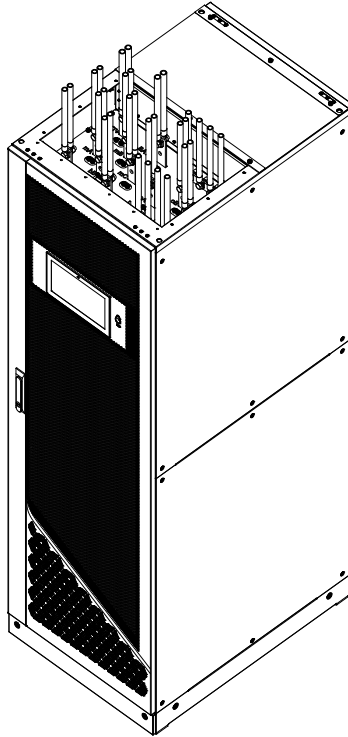

The cabinet also supports bottom cable entry and exit via an optional side cabinet, as shown in Figure 4-5

Figure 4-5 Bottom entry

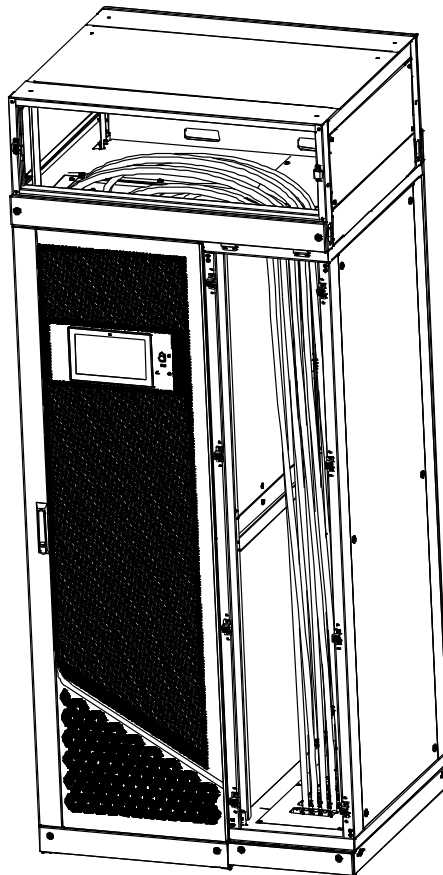

## 4.4 Power cables

### 4.4.1 Power cable specifications

UPS power cables shall be selected in accordance with Table 3B of IEC 60950-1 and the application requirements. The maximum operating currents of the power cables are listed in Table 4-1. The recommended cable cross-sectional areas are provided in Table 4-2.

Table 4-1 Maximum operating currents of power cables

Item		6-module cabinet
Mains input	Mains input current (A)	600
Mains output	Mains output current (A)	455
Bypass input	Bypass input current (A)	455
Battery input	Battery input current (A)	823

Table 4-2 Recommended cable cross-sectional area (unit: mm<sup>2</sup>, ambient temperature: 25°C)

Model	Input	Output	Bypass	Neutral (N)	PE	Battery
300kVA	2×150	2×120	2×120	2×120	2×95	3×120

The recommended cables in Table 4-2 apply only under the following conditions:

- The DC voltage drop is < 1%, and the DC cable lengths in the table are ≤ 30m. Increase the cable cross-sectional area if the routing distance exceeds this limit.
- At an ambient temperature of 30°C, 90°C copper conductor flexible cables shall be verified in accordance with IEC 60364-5-52 and relevant local regulations when external conditions change. The current values in the table are based on the maximum steady-state current data at a rated line voltage of 380V. For 400V rated voltage, the current values should be multiplied by 0.95; for 415V rated voltage, the current values should be multiplied by 0.92.
- When the main load is non-linear or unbalanced, increase the cross-sectional area of the neutral cable to 1.5–1.7 times that of each phase output cable.
- For shared input configurations, consider using multiple cables with a smaller cross-sectional area in parallel to facilitate installation.

### 4.4.2 Power cable terminal specifications

Table 4-3 Cable terminal requirements

Model	Interface	Connection mode	Bolt size	Tightening torque
RM300 cabinet	Mains input	Crimped OT terminal	M12	28N · m
	Bypass input	Crimped OT terminal	M12	28N · m
	Battery input	Crimped OT terminal	M12	28N · m
	Output	Crimped OT terminal	M12	28N · m
	Protective earth	Crimped OT terminal	M12	28N · m

### 4.4.3 External circuit breaker selection

The UPS system requires external power distribution circuit breakers, including the mains input breaker, bypass input breaker (for dual input configuration), output breaker, maintenance bypass breaker, and external battery breaker. The recommended circuit breaker specifications are listed in Table 4-4.

Table 4-4 Recommended circuit breaker specifications

Circuit breaker installation location	6-module cabinet
Mains input (upstream)	630A/3P
Bypass input (upstream)	500A/3P
Output (downstream)	500A/3P
Maintenance bypass	500A/3P
Battery output (downstream)	1000A/3P (DC circuit breaker)

**Note:**

- Circuit breakers with leakage protection function are not recommended.
- The breakers downstream of the battery output must meet the requirements for DC applications and battery voltage.

### 4.4.4 Power cable wiring

The wiring procedure is as follows:

- Step 1 Verify that all input distribution switches and internal power switches are open. Attach warning tags to these switches to prevent unauthorized operation.
- Step 2 Remove the cabinet top panel to access the input, output, bypass, battery, and grounding terminals. The terminal layout is shown in Figure 4-6.

Figure 4-6 Terminal layout

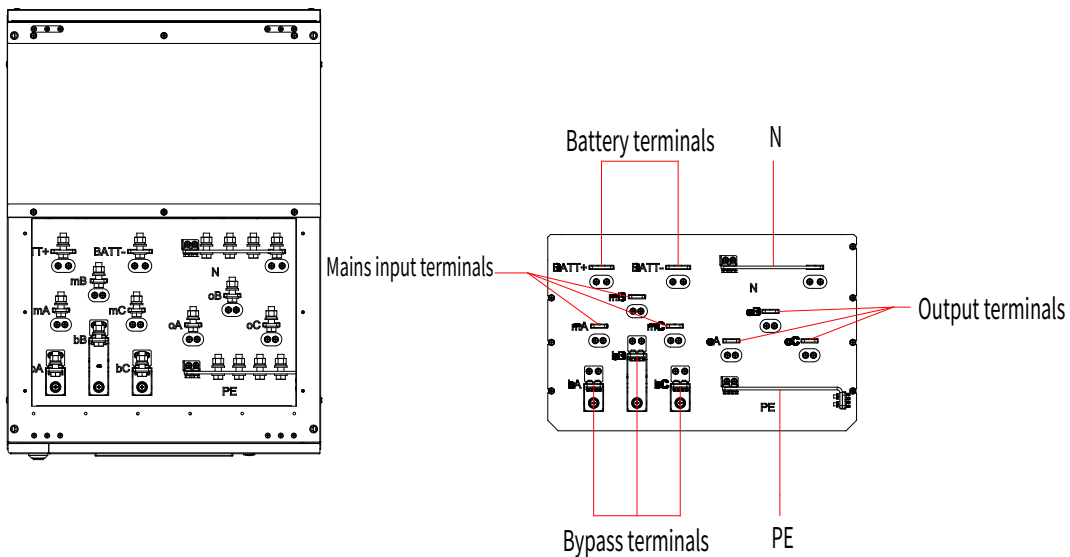

- Step 3 Connect the input PE conductor to the input PE terminal. Ensure that the connection complies with the applicable local and national regulations.
- Step 4 As shown in Figure 4-6, connect the mains input cables to the UPS mains input terminals (mA, mB, mC, N), the bypass input cables to the UPS bypass input terminals (bA, bB, bC, N), and the output load cables to the UPS output terminals (oA, oB, oC, N).
- Step 5 Connect the battery cables to the UPS battery terminals (BATT+, N, BATT-).
- Step 6 Verify that all connections are correct to complete the wiring.

**Note:**

- When connecting power cables, comply with the torque specifications listed in Table 4-3 to ensure proper tightening of the terminals and avoid potential safety hazards.
- Before wiring the UPS, make sure you are aware of the location and status of the switches that connect

the UPS input to the mains power distribution. Ensure all switches are open and attach warning labels to prevent others from operating them.

### 4.5 Control cables and communication cables

The cabinet front panel provides dry contact interfaces (EPO, NTC, IP, and OP) and communication interfaces (CAN, RS485, intelligent card, and USB), as shown in Figure 4-7.

Figure 4-7 Communication interfaces

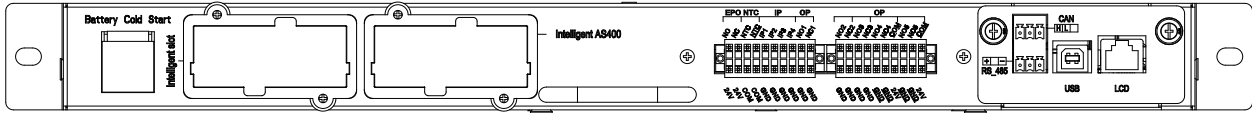

#### 4.5.1 Dry contact interfaces

The dry contact interfaces include the EPO, NTC, IP, and OP functions, as shown in Figure 4-8. The functions can be configured through the monitoring software. Available functions are detailed in Table 4-5.

Figure 4-8 Dry contact interfaces

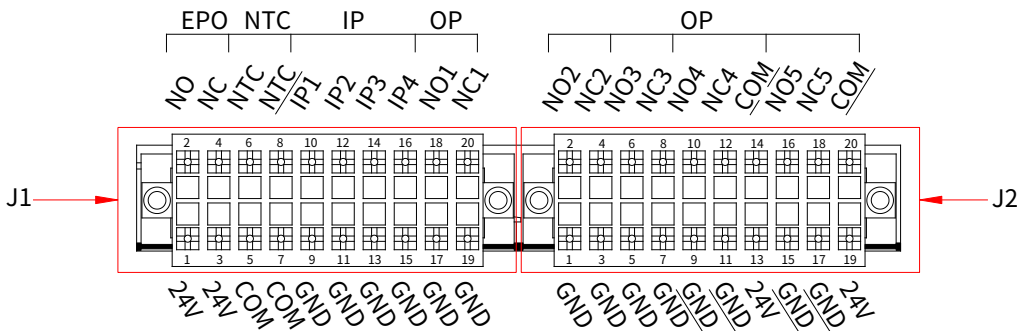

Table 4-5 Dry contact interface definitions

Location	Name	Function
J1-1, J1-3	EPO-24V	Internal 24V power supply
J1-2	EPO-NO	Triggers Emergency Power Off (EPO) when shorted to EPO-24V.
J1-4	EPO-NC	Triggers EPO when disconnected from EPO-24V.
J1-6	NTC-NTC	Battery temperature detection
J1-8	NTC- <u>NTC</u>	Ambient temperature detection
J1-5, J1-7	NTC-COM	Temperature detection common reference point
J1-10	IP-IP1	Built-in input dry contact with configurable function. Default function: Generator input.
J1-12	IP-IP2	Built-in input dry contact with configurable function. Default function: Battery circuit breaker (BCB) status. An invalid BCB status detection will trigger a BCB status detection fault. If BCB online detection is enabled but the signal is not detected, or if BCB online detection is disabled, the BCB status dry contact setting will be invalid.
J1-14	IP-IP3	Built-in input dry contact with configurable function. Default function: BCB online. BCB status detection is performed only when the BCB online dry contact detects that the battery is present.

Location	Name	Function
J1-16	IP-IP4	Built-in input dry contact with configurable function. Default function: Mute.
J1-9, J1-11, J1-13, J1-15, J1-17, J1-19	IP-GND	Internal 24V power supply reference ground
J1-18	OP-NO1	Built-in output dry contact (normally open) with configurable function. Default function: Battery CB trip signal (active under EOD or EPO).
J1-20	OP-NC1	Built-in output dry contact (normally closed) with configurable function. Default function: Battery CB trip signal (active under EOD or EPO).
J2-2	OP-NO2	Built-in output dry contact (normally open) with configurable function. Default function: Battery low voltage alarm.
J2-4	OP-NC2	Built-in output dry contact (normally closed) with configurable function. Default function: Battery low voltage alarm.
J2-6	OP-NO3	Built-in output dry contact (normally open) with configurable function. Default function: General alarm.
J2-8	OP-NC3	Built-in output dry contact (normally closed) with configurable function. Default function: General alarm.
J2-10	OP-NO4	Built-in output dry contact (normally open) with configurable function. Default function: Mains abnormality alarm.
J2-12	OP-NC4	Built-in output dry contact (normally closed) with configurable function. Default function: Mains abnormality alarm.
J2-14	OP- <u>COM</u>	OP-4 common reference point, optional external VCC or internal 24V power supply.
J2-16	OP-NO5	Built-in output dry contact (normally open) with configurable function. Default function: Overload alarm.
J2-18	OP-NC5	Built-in output dry contact (normally closed) with configurable function. Default function: Overload alarm.
J2-20	OP- <u>COM</u>	OP-5 common reference point, optional external VCC or internal 24V power supply.
J2-1, J2-3, J2-5, J2-7	OP-GND	Built-in output dry contact GND
J2-9, J2-11, J2-15, J2-17	OP- <u>GND</u>	OP-4 and OP-5 output dry contacts, optional external VCC reference ground
J2-13, J2-19	OP-24V	Internal 24V power supply

The functions of the dry contacts can be set via the monitoring software.

The default function of each dry contact is described as follows:

■ **Remote EPO input interface**

When the UPS system is operating normally, pins EPO-NC and EPO-24V must be shorted, and pins EPO-NO and EPO-24V must be open. If EPO-NC and EPO-24V are open, or EPO-NO and EPO-24V are shorted, an emergency shutdown will be triggered. The wiring method is shown in Figure 4-9.

Figure 4-9 Remote EPO input interface

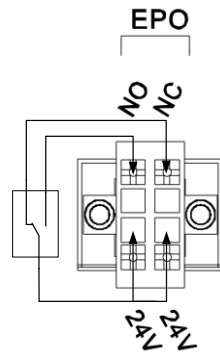

■ **Dry contact interface for battery and ambient temperature detection**

The NTC/NTC input dry contact is used to detect battery temperature (BAT\_TEMP) and ambient temperature (ENV\_TEMP). The wiring method is shown in Figure 4-10.

Figure 4-10 Temperature detection dry contact interface

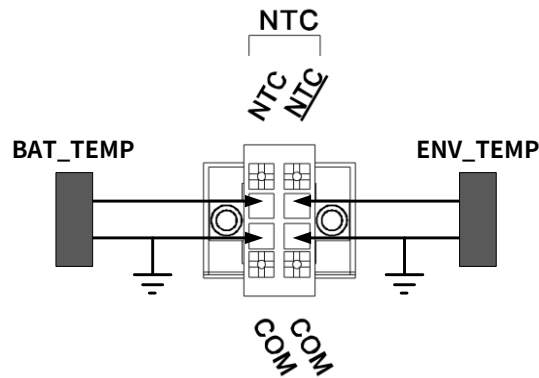

Temperature detection requires the use of a specific temperature sensor (R25=5kΩ, B25/50=3275). Verify with the manufacturer or contact the local office when placing an order.

■ **Generator connection status dry contact**

IP-IP1 is used by default as the generator connection status interface. The generator is considered connected to the system when IP1 is shorted to IP1-GND through the switch. The wiring method is shown in Figure 4-11.

Figure 4-11 Generator connection status interface and wiring diagram

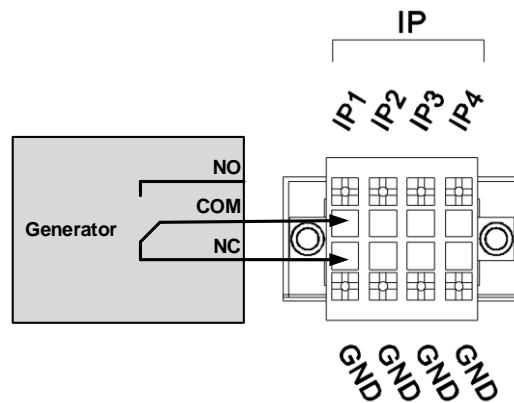

The wiring diagrams for the IP-IP2, IP-IP3, and IP-IP4 input dry contacts are the same as for IP-IP1.

■ **Battery CB trip signal output dry contact**

OP-1 is an output dry contact interface, with the default function set to the battery CB trip signal (active under EOD or EPO). When the battery issues a CB trip signal, a relay-isolated dry contact signal is provided. The wiring method is shown in Figure 4-12.

Figure 4-12 Battery CB trip signal output dry contact

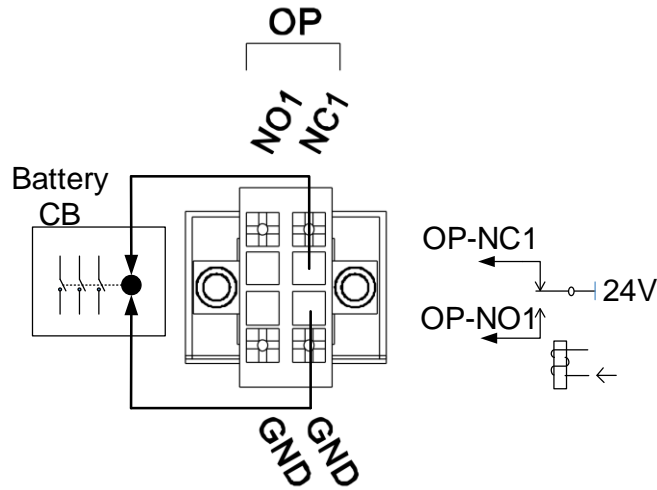

The wiring diagrams for the OP-2 and OP-3 output dry contacts are the same as for OP-1.

🔗**Note:**

- The shunt trip coil can be powered by an external 24VDC power supply or by the UPS itself.
- The 24V power supplied by the UPS itself can provide a maximum current of 400mA. If the current required by the shunt trip coil exceeds this limit, an intermediate relay must be used.
- If the shunt trip coil operates at 220V or any other voltage level, an intermediate relay is also required.

■ **Mains fault alarm output dry contact**

OP-4 is by default the mains fault alarm output dry contact interface. When a mains failure occurs, the system generates a mains fault alarm and provides a relay-isolated dry contact signal. The wiring method is shown in Figure 4-13. If the UPS internal 24V power supply is used, short 24V to COM.

Figure 4-13 Mains fault alarm dry contact interface

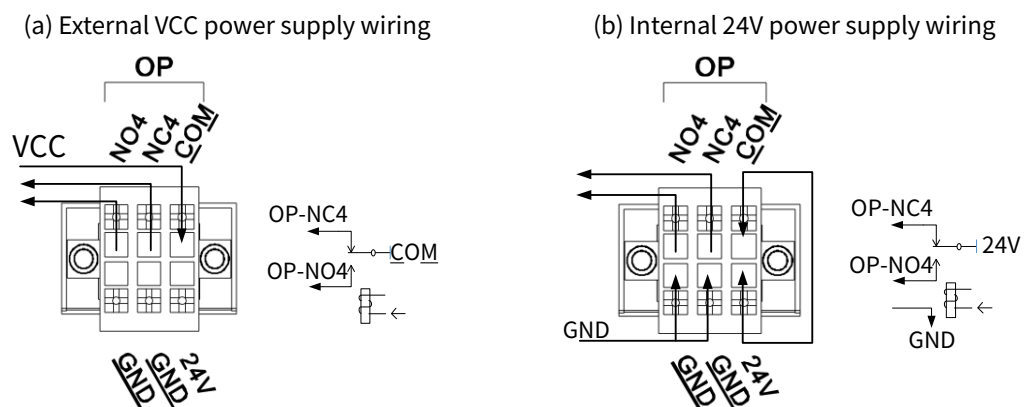

GND serves as the ground for the external VCC power supply. It is only used for external power ground connection at the interfaces J2-9, J2-11, J2-15, and J2-17. When the UPS internal 24V power supply is connected to COM, if the GND interface is used, short one of the J2-9, J2-11, J2-15, or J2-17 interfaces to GND (such as J2-1, J2-3, J2-5, or J2-7).

🔗**Note:** The dry contact has a maximum current rating of 5A. If the drive current required by the shunt

trip coil exceeds this limit, use an external power supply and an intermediate relay. The wiring method is shown in Figure 4-14.

Figure 4-14 Wiring between the dry contact and external intermediate relay

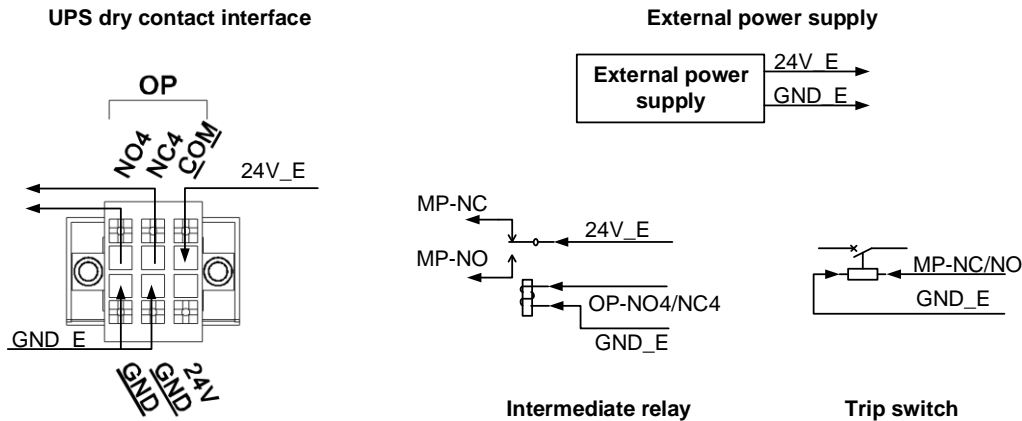

■ **Overload alarm output dry contact**

OP-5 is, by default, the overload alarm output dry contact interface. When an overload occurs, the system generates an overload alarm and provides an auxiliary relay-isolated dry contact signal. The wiring method is shown in Figure 4-13. If the UPS internal 24V power supply is used, short 24V to COM.

**4.5.2 Communication interfaces**

CAN, RS485, and USB: Provide serial communication for authorized personnel to commission and maintain the UPS. They can also be used for networking and integration with the equipment room monitoring system.

Intelligent card slot: Used for installing optional cards, including the SNMP card, RS485 card, and intelligent AS400 card. The installation locations and models of the optional cards are shown in Figure 4-15 and listed in Table 4-6.

Figure 4-15 Communication interfaces and locations

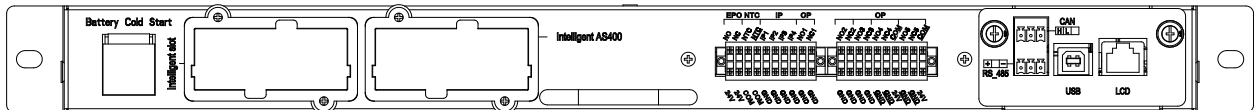

Table 4-6 Installation locations and models of optional cards

Optional card	Model	Function	Installation location
SNMP card	SNMP-PS-3-B	Intelligent communication card	Intelligent Slot
RS485 expansion card	RMD-RS485	Communication with the BMS	Intelligent Slot
Intelligent AS400 card	RMD-AS400	Dry contact expansion interface	Intelligent AS400

# 5 Control panel

## 5.1 Cabinet control panel

The UPS control panel is located on the cabinet front panel, as shown in Figure 5-1.

Figure 5-1 Control panel

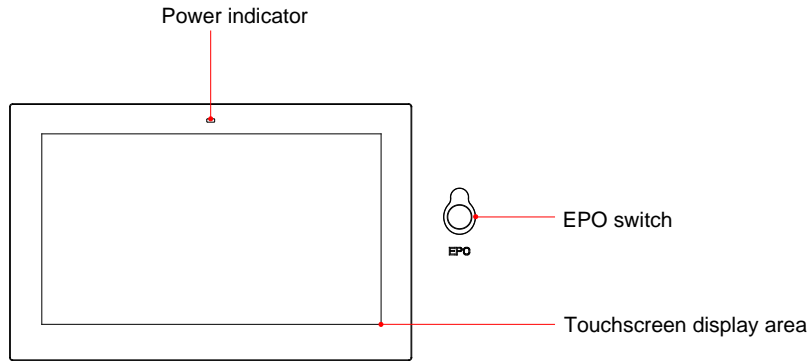

### 5.1.1 Audible alarms

During operation, the buzzer emits various alarm tones to indicate different alarm states, as detailed in Table 5-1.

Table 5-1 Audible alarm description

Audible alarm	Description
Two short beeps and one long beep	A UPS alarm has occurred (for example, when AC power is abnormal).
Continuous beeping	The UPS has a fault (such as a hardware failure or battery EOD).

### 5.1.2 Control keys

Table 5-2 Control key description

Control key	Description
EPO	Press and hold the EPO switch to cut off power to the load, shut down the rectifier, inverter, and static bypass, and disable battery charging/discharging.

### 5.1.3 Touchscreen display area

After the UPS is powered on, the monitoring system performs a self-check. The control panel will display three static white dots. After approximately 40s, it enters the main screen (home screen), as shown in Figure 5-2.

Figure 5-2 Main screen (Home)

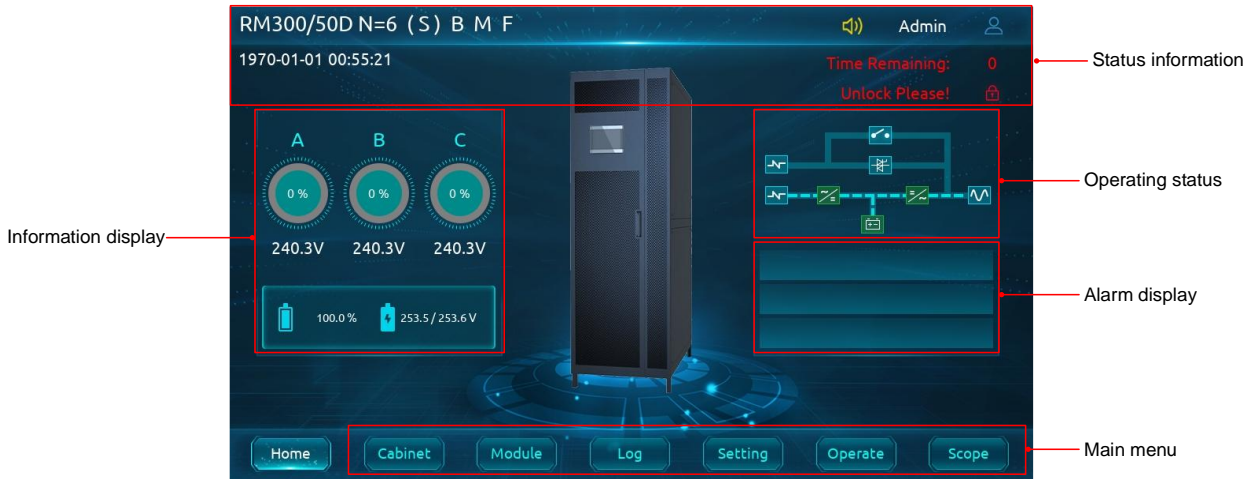

The main screen (home screen) primarily includes status information, information display, operating status, alarm display, and the main menu.

■ **Status information**

Includes the UPS series and model, parallel operation mode, the number of power modules in parallel operation, current time, logged-in user, and other related information.

■ **Information display**

You can view key cabinet information in this area.

- ◇ The load percentage is indicated by the gauges.
  - Green zone: Load is less than 60%.
  - Yellow zone: Load is between 60% and 100%.
  - Red zone: Load exceeds 100%.
- ◇ The cabinet input voltage, battery positive and negative voltages, and battery capacity are displayed as numerical values.

■ **Operating status**

This area graphically displays the status of various components within the UPS system.

- ◇ Green: The power module is operating normally.
- ◇ Red: The function is unavailable (for example, a red battery icon indicates that the battery is not connected to the system)
- ◇ Gray: The function is inactive.
- ◇ Power flow status: Indicates that the module is outputting power.

■ **Alarm display**

Displays the current alarm information of the UPS.

■ **Main menu**

The main menu is used to display various UPS status information, fault and alarm messages, and to configure the UPS. It mainly consists of six items: **Cabinet**, **Module**, **Log**, **Setting**, **Operate**, and **Scope**. The structure of the main menu is shown in Figure 5-3.

Figure 5-3 Main menu structure

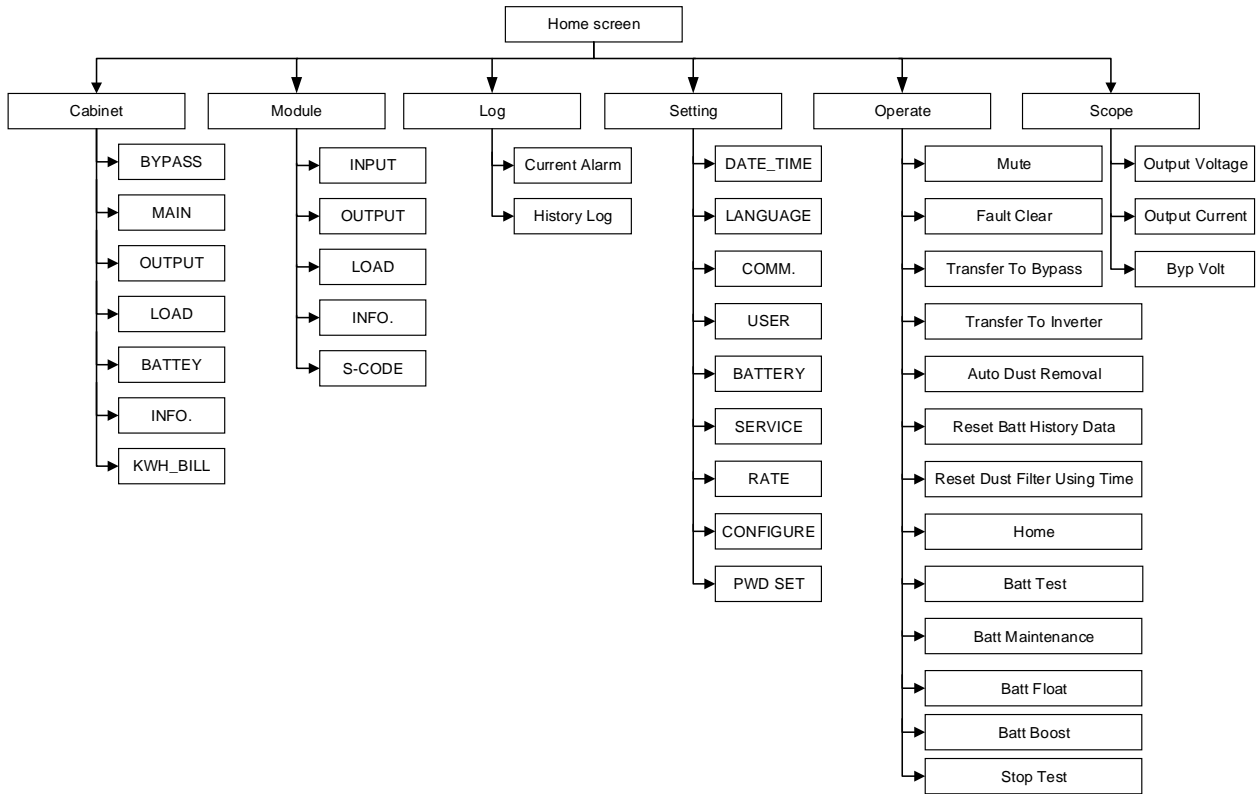

## 5.2 Main menu

### 5.2.1 Cabinet

On the home screen, tap the  button at the bottom of the touchscreen to access the screen shown in Figure 5-4.

Figure 5-4 Cabinet (BYPASS)



The **Cabinet** (BYPASS) screen is composed of the information display, version information, and submenus.

■ **Information display**

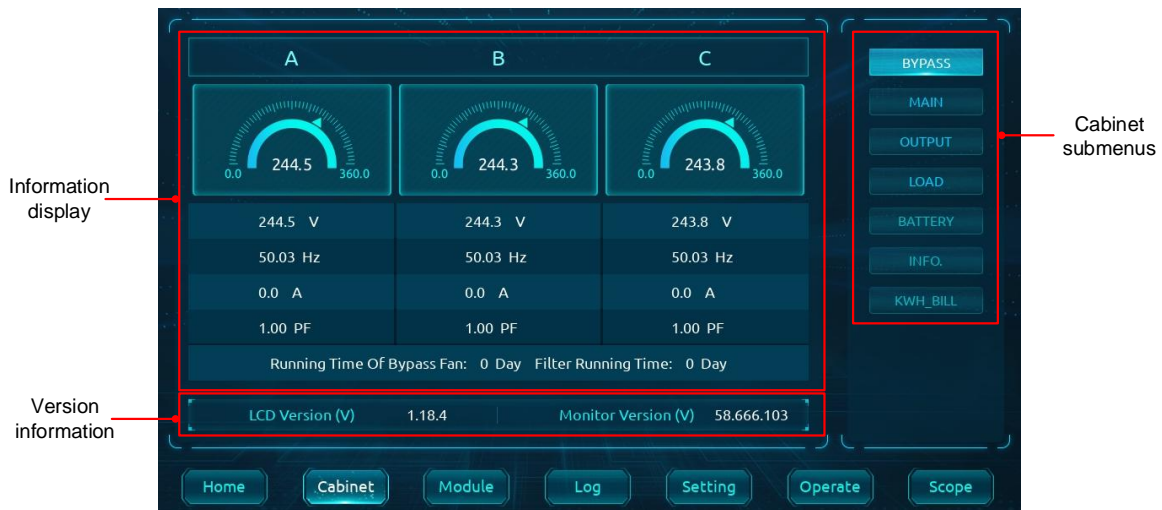
- ◇ Dynamic gauges: Display the voltage of each phase.
- ◇ Values below the gauges: Display the three-phase bypass voltage, frequency, current, and power factor.
- ◇ Running time: Shows the accumulated running time of the bypass fan and the accumulated service time of the dust filter.

■ **Version information**

Indicates the LCD software version number and the monitoring software version number.

■ **Submenus under Cabinet**

The following submenus are available under **Cabinet: BYPASS, MAIN, OUTPUT, LOAD, BATTERY, INFO.,** and **KWH\_BILL**. Tap the corresponding icon to access its screen, as shown in Figure 5-4, Figure 5-5, Figure 5-6, Figure 5-7, Figure 5-8, Figure 5-9, and Figure 5-10.

Figure 5-5 Cabinet (MAIN)



Figure 5-6 Cabinet (OUTPUT)

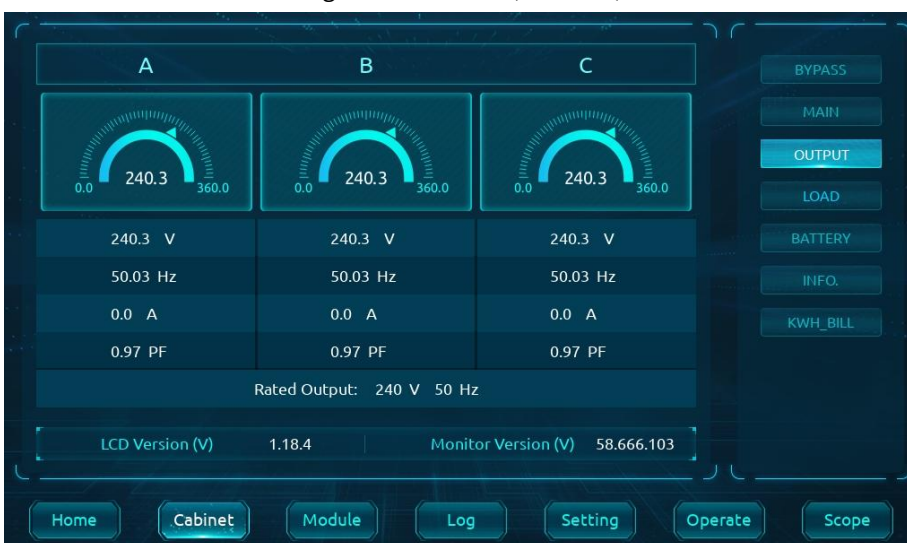

Figure 5-7 Cabinet (LOAD)



Figure 5-8 Cabinet (BATTERY)



Figure 5-9 Cabinet (INFO.)



Figure 5-10 Cabinet (KWH\_BILL)



The **Cabinet** submenus are detailed in Table 5-3.

Table 5-3 Submenus under Cabinet

Submenu	Item	Description
BYPASS	Phase voltage (V)	Bypass input phase voltage
	Frequency (Hz)	Bypass input frequency
	Phase current (A)	Bypass input phase current
	Power factor (PF)	Bypass input power factor
MAIN	Phase voltage (V)	Mains input phase voltage
	Frequency (Hz)	Mains input frequency
	Phase current (A)	Mains input phase current
	Power factor (PF)	Mains input power factor
OUTPUT	Phase voltage (V)	Output phase voltage
	Frequency (Hz)	Output frequency
	Phase current (A)	Output phase current
	Power factor (PF)	Output power factor
LOAD	Load percentage (%)	Load percentage
	Active power (kW)	Active power
	Apparent power (kVA)	Apparent power
	Reactive power (kVAr)	Reactive power
BATTERY	Number	Battery quantity setting
	Batt Status	Current detected battery connection status
	Running Time (Day)	Accumulated battery operating time
	(+/-) Battery Pack Volt (V)	Positive/negative voltage of the battery pack
	(+/-) Battery Pack Curr (A)	Positive/negative current of the battery pack
	Battery Dischar Hours (H)	Battery discharge time since startup
	Battery Dischar Times (Num)	Number of battery discharges since startup
	Capacity (%)	Remaining battery capacity in percentage
	Remaining Time (Min)	Remaining battery backup time
	Battery Temp. (°C)	Battery temperature (available with optional Negative Temperature Coefficient thermistor (NTC))

Submenu	Item	Description
	Ambient Temp. (°C)	Battery ambient temperature (available with optional NTC)
	Batt Cont NoDschg T (Day)	Battery continuous non-discharge time
INFO.	Byp SCR1 Temp. (°C)	1# bypass module 1# SCR module temperature
	Byp SCR2 Temp. (°C)	1# bypass module 2# SCR module temperature
	Byp SCR3 Temp. (°C)	2# bypass module 1# SCR module temperature
	Byp SCR4 Temp. (°C)	2# bypass module 2# SCR module temperature
	NTC1 Temp. (°C)	Cabinet internal point 1# temperature (available with optional NTC)
	NTC2 Temp. (°C)	Cabinet internal point 2# temperature (available with optional NTC)
	Byp Module 1 Knob Status	Bypass module 1# slide switch status
	Byp Module 2 Knob Status	Bypass module 2# slide switch status
	MTR Air Inlet Temp. (°C)	Air inlet temperature of the monitoring module
KWH_BILL	Charge Rate Price (¥/MWh)	Battery charging period electricity rate
	Discharge Rate Price (¥/MWh)	Battery discharging period electricity rate
	Chg Kwh (KWh)	Energy consumed during battery charging cycles on the current day
	Cum Chg (KKWh)	Cumulative energy consumed during battery charging cycles over the UPS operating period
	Dchg Kwh (KWh)	Energy consumed during battery discharging cycles on the current day
	Cum Dchg (KKWh)	Cumulative energy consumed during battery discharging cycles over the UPS operating period
	Chg Cost (CN ¥)	Electricity cost incurred during battery charging cycles on the current day
	Tot ChgC (CN ¥ 10K)	Electricity cost incurred during battery charging cycles over the UPS operating period
	Dchg Inc (CN ¥)	Electricity cost savings during battery discharging cycles on the current day
	Tot Dchgl (CN ¥ 10K)	Electricity cost savings during battery discharging cycles over the UPS operating period
	Day Save (CN ¥)	Electricity cost savings from battery charging and discharging cycles on the current day
	Tot Sav (CN ¥ 10K)	Electricity cost savings from battery charging and discharging cycles over the UPS operating period

### 5.2.2 Module

On the home screen, tap the  button at the bottom of the touchscreen to access the screen shown in Figure 5-11.

Figure 5-11 Module (INPUT)





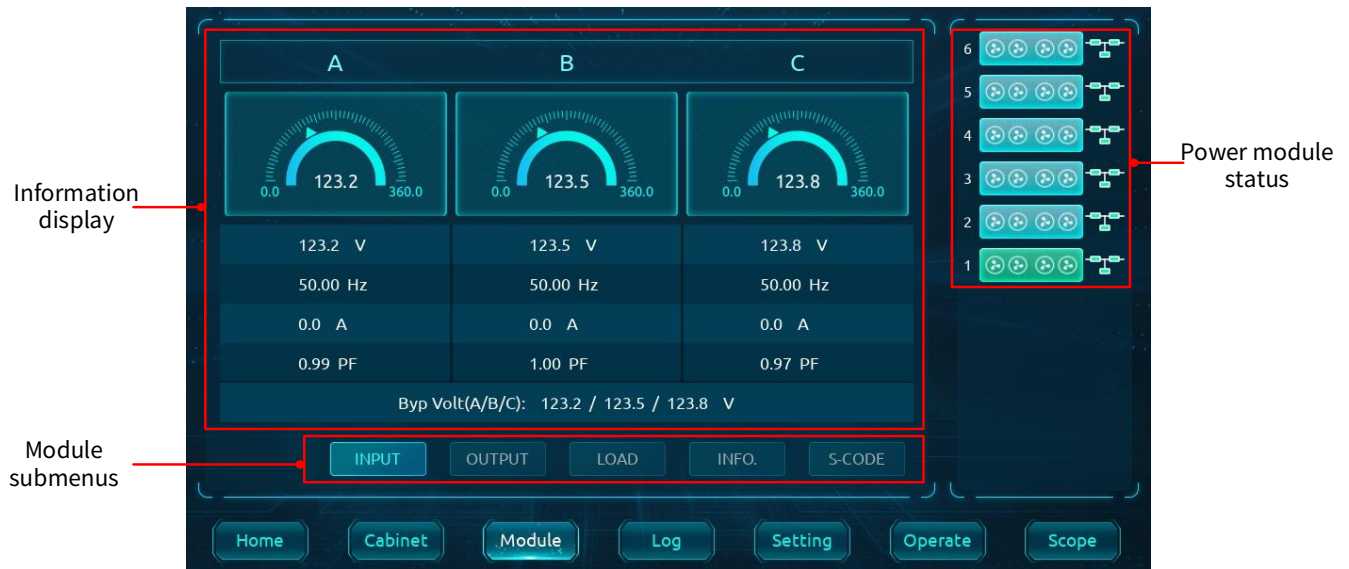

The **Module (INPUT)** screen consists of the information display, power module status, and submenus.

■ **Information display**

This area displays the information of the selected power module, mainly including voltage, frequency, current, and power factor.

■ **Power module status**

- ◇ Power module number: 1–6 from bottom to top.
- ◇ Displays whether a power module is inserted and selected:
  - : Module is not inserted or communication is abnormal.
  - : Module is inserted and communication is normal.
  - : Module is selected.
  - : Module is inserted and communication is normal. However, the slide switch is not moved to the right to the closed position.
- ◇ Power module status:
  - Green box: Indicates that the power module is operating normally.
  - Red box: Indicates that the power module is not connected or is faulty.

■ **Submenus under Module**

The following submenus are available under **Module: INPUT, OUTPUT, LOAD, INFO., and S-CODE**. Tap the corresponding icon to access its screen, as shown in Figure 5-11, Figure 5-12, Figure 5-13, Figure 5-14, and Figure 5-15.

Figure 5-12 Module (OUTPUT)



Figure 5-13 Module (LOAD)



Figure 5-14 Module (INFO.)



Figure 5-15 Module (S-CODE)



The **Module** submenus are detailed in Table 5-4.

Table 5-4 Submenus under Module

Submenu	Item	Description
Input	Phase voltage (V)	Input phase voltage
	Frequency (Hz)	Input frequency
	Phase current (A)	Input phase current
	Power factor (PF)	Input power factor
OUTPUT	Phase voltage (V)	Output phase voltage
	Frequency (Hz)	Output frequency
	Phase current (A)	Output phase current
	Power factor (PF)	Output power factor
LOAD	Load percentage (%)	Output load percentage
	Active power (kW)	Output active power
	Apparent power (kVA)	Output apparent power
	Phase voltage (V)	Inverter voltage
INFO.	(+/-) Battery Pack Volt (V)	Positive/negative voltage of the battery pack
	(+/-) Battery Pack Curr (A)	Positive/negative current of the battery pack
	(+/-) BUS (V)	Positive/negative bus voltage
	(+/-) Charger (V)	Positive/negative voltage of the charger
	Fan Time (Day)	Accumulated running time of the fan
	FanPred.Life (H)	Predicted fan life
	Capacitor Time (Day)	Accumulated operating time of the capacitor
	Pred.LifeOfBusCap (H)	Predicted bus capacitor life
	Thin-FilmCapRun-Time (Day)	Accumulated operating time of the film capacitor
	Pred.LifeOfThinFilmCap (H)	Predicted film capacitor life
	(A/B/C) REC IGBT Temp. (°C)	A/B/C-phase rectifier IGBT temperature (°C)
	(A/B/C) INV IGBT Temp. (°C)	A/B/C-phase inverter IGBT temperature (°C)
	Air Inlet Temp. (°C)	Air inlet temperature of the power module
	Air Outlet Temp. (°C)	Air outlet temperature of the power module
REC VER (V)	Rectifier software version number of the module	
INV VER (V)	Inverter software version number of the module	
S-CODE	UPS fault code	For use by qualified service personnel

### 5.2.3 Log

On the home screen, tap the  button at the bottom of the touchscreen to access the screen shown in Figure 5-16.

Figure 5-16 Log (Current Alarm)



■ **Submenus under Log**

The following submenus are available under **Log: Current Alarm** and **History Log**. Tap the corresponding icon to access its screen, as shown in Figure 5-16 and Figure 5-17.

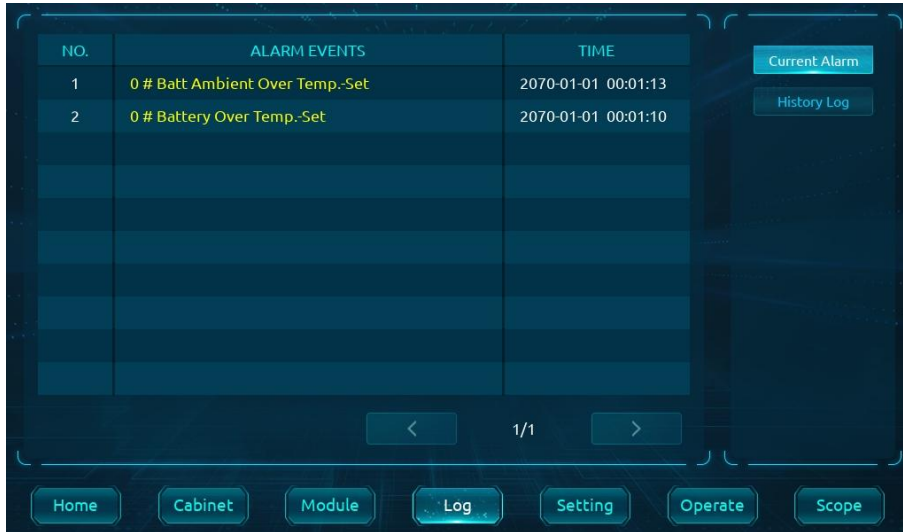
Figure 5-17 Log submenu (History Log)

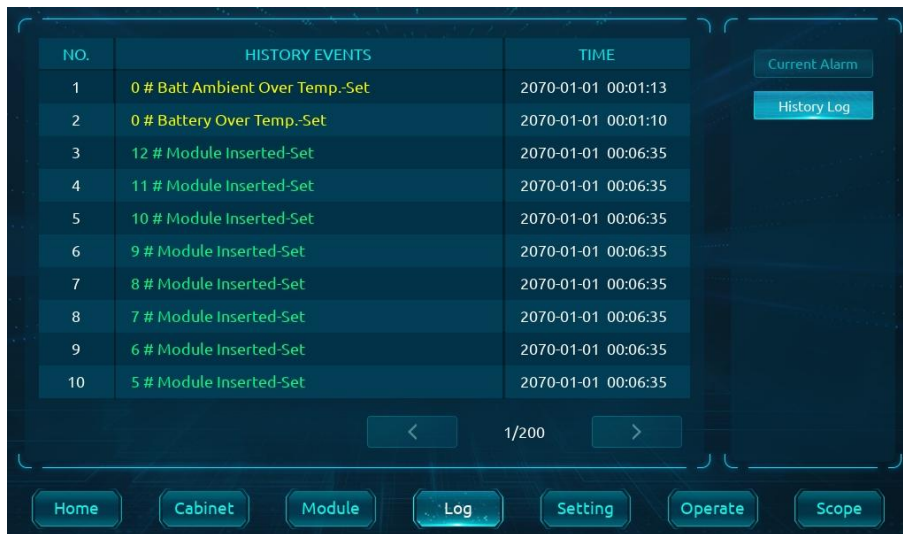

Alarms and event logs are detailed in Table 5-5.

Table 5-5 System events and alarms

Event	Description
Load On UPS-Set	System in normal inverter power supply
Load On Bypass-Set	System in bypass power supply
No Load-Set	No output from the system
Battery Boost-Set	Battery in boost charge
Battery Float-Set	Battery in float charge
Battery Discharge-Set	System operating in battery discharge status

Event	Description
Battery Connected-Set	Battery connected
Battery Not Connected-Set	Battery disconnected
Maintenance CB Closed-Set	Maintenance circuit breaker closed
Maintenance CB Open-Set	Maintenance circuit breaker open
EPO-Set	Emergency power off
EPO-Clear	Emergency power off cleared
Module On Less-Set	Inverter output power less than load power
Module On Less-Clear	Inverter output power greater than load power
Generator Input-Set	External generator connected
Generator Input-Clear	External generator disconnected after connection
Utility Abnormal-Set	Input mains abnormal
Utility Abnormal-Clear	Mains restored to normal
Bypass Sequence Error-Set	Bypass phase sequence reversed
Bypass Sequence Error-Clear	Bypass phase sequence restored to normal
Bypass Volt Abnormal-Set	Bypass voltage abnormal
Byp Volt Abnormal-Clear	Bypass voltage restored to normal
Bypass Module Fail-Set	Bypass fault occurred
Bypass Module Fail-Clear	Bypass restored to normal
Bypass Overload-Set	Bypass output overload
Bypass Overload-Clear	Bypass output restored to normal
Bypass Overload Tout-Set	Bypass output overload delay timeout
Byp Overload Tout-Clear	Bypass overload delay timeout cleared
Byp Freq. Over Track-Set	Bypass frequency out of tracking range
Byp Freq. Over Track-Clear	Bypass frequency restored to tracking range
Exceed Tx Times Lmt-Set	Switching between bypass and inverter exceeded 5 times in the past hour
Exceed Tx Times Lmt-Clear	Switching count cleared
Output Short Circuit-Set	System output short circuit
Output Short Circuit-Clear	System output short circuit cleared
Battery EOD-Set	Battery voltage reached the shutdown voltage
Battery EOD-Clear	Battery voltage restored above the shutdown voltage
Battery Test-Set	System entered battery self-test mode
Battery Test OK-Set	Battery self-test normal
Battery Test Fail-Set	Battery fault detected during system self-test
Battery Maintenance-Set	System in battery maintenance status
Batt Maintenance OK-Set	Battery maintenance completed
Batt Maintenance Fail-Set	Battery maintenance incomplete
Stop Test-Set	Battery self-test or maintenance stopped
Fault Clear-Set	Reported fault cleared
Log Clear-Set	All logs deleted
N# Module Inserted-Set	N# power module joined the system
N# Module Exit-Set	N# power module left the system
N# Rectifier Fail-Set	N# power module rectifier fault
N# Rectifier Fail-Clear	N# power module rectifier fault cleared
N# Inverter Fail-Set	N# power module inverter fault
N# Inverter Fail-Clear	N# power module inverter fault cleared
N# Rectifier Over Temp.-Set	N# power module rectifier overtemperature
N# Rectifier Over Temp.-Clear	N# power module rectifier overtemperature cleared

Event	Description
N# Fan Fail-Set	N# power module fan fault, not properly connected or stalled
N# Fan Fail-Clear	N# Fan restored to normal
N# Output Overload-Set	N# power module output overload
N# Output Overload-Clear	N# power module output restored
N# Inverter Overload Tout-Set	N# power module inverter overload timeout
N# Inverter Overload Tout-Clear	N# power module inverter overload timeout cleared
N# Inverter Over Temp.-Set	N# power module inverter overtemperature
N# Inverter Over Temp.-Clear	N# power module inverter overtemperature cleared
On UPS Inhibited-Set	Inverter power supply disabled
On UPS Inhibited-Clear	Inverter power supply enabled
Manual Transfer Byp-Set	System manually switched to bypass output
Esc Manual Bypass-Set	System manually switched from bypass to inverter output
Battery Volt Low-Set	Battery voltage low
Battery Volt Low-Clear	Battery voltage restored to normal
Battery Wiring Error-Set	Battery wiring reversed
Battery Wiring Error-Clear	Battery wiring correct
N# Inverter Protect-Set	N# power module inverter protection activated
N# Inverter Protect-Clear	N# power module inverter protection deactivated
Input Neutral Lost-Set	Input neutral disconnected
Bypass Fan Fail-Set	Monitoring module and bypass module fan fault
Bypass Fan Fail-Clear	Monitoring module and bypass module fan fault cleared
N# Manual Shutdown-Set	N# power module manually shut down
Manual Boost Charge-Set	Manually switched to boost charge
Manual Float Charge-Set	Manually set to float charge
UPS Locked-Set	UPS forced shutdown
Parallel Cable Error-Set	Parallel cable connection fault
Parallel Cable Error-Clear	Parallel cable connection fault cleared
N# Batt or Charger Fail-Set	N# power module battery or charger fault
N# Batt or Charger Fail-Clear	N# power module battery or charger fault cleared
N+X Redundant Lost-Set	Cabinet N+X redundancy loss
N+X Redundant Lost-Clear	Cabinet N+X redundancy restored
EOD System Inhibited-Set	-
EOD System Inhibited-Clear	-
Signal Cable Fail-Set	Signal cable connection fault
Signal Cable Fail-Clear	Signal cable connection fault cleared
Batt Ambient Over Temp.-Set	Battery ambient overtemperature
Batt Ambient Over Temp.-Clear	Battery ambient temperature restored to normal
REC CAN Fail-Set	Monitoring module rectifier CAN signal abnormal
REC CAN Fail-Clear	Monitoring module rectifier CAN signal restored to normal
INV IO CAN Fail-Set	Monitoring module inverter CAN signal abnormal
INV IO CAN Fail-Clear	Monitoring module inverter CAN signal restored to normal
INV DATA CAN Fail-Set	Monitoring module inverter data CAN abnormal
INV DATA CAN Fail-Clear	Monitoring module inverter data CAN restored to normal
N# Power Share Fail-Set	N# power module power difference too large
N# Power Share Fail-Clear	N# power module power difference returned to normal
N# Sync Pulse Fail-Set	N# power module sync signal abnormal
N# Sync Pulse Fail-Clear	N# power module sync signal restored to normal
N# Input Volt Detect Fail-Set	N# power module input voltage abnormal

Event	Description
N# Input Volt Detect Fail-Clear	N# power module input voltage restored to normal
N# Battery Volt Detect Fail-Set	Abnormal battery voltage detected by n# power module
N# Batt Volt Detect Fail-Clear	Battery voltage restoration detected by n# power module
N# Output Volt Test Exception-Set	N# power module output voltage abnormal
N# Output Volt Test Exception-Clear	N# power module output voltage restored to normal
N# Bypass Volt Detect Fail-Set	Abnormal bypass voltage detected by n# power module
N# Bypass Volt Detect Fail-Clear	Bypass voltage restoration detected by n# power module
N# INV Bridge Fail-Set	N# power module inverter fault
N# INV Bridge Fail-Clear	N# power module inverter fault cleared
N# Outlet Temp. Error-Set	N# power module air outlet temperature out of the set range
N# Outlet Temp. Error-Clear	N# power module air outlet temperature restored to normal
N# Input Curr Unbalance-Set	N# power module three-phase input current imbalance
N# Input Curr Unbalance-Clear	N# power module input current restored to normal
N# DC Bus Over Volt-Set	N# power module DC bus overvoltage
N# DC Bus Over Volt-Clear	N# power module bus voltage restored to normal
N# REC Soft Start Fail-Set	N# power module rectifier start failure
N# REC Soft Start Fail-Clear	N# power module rectifier restored to normal
N# INV Relay Open-Set	N# power module relay failure to close
N# INV Relay Open-Clear	N# power module relay closed
N# Relay Short Circuit-Set	N# power module inverter switch short circuit
N# Relay Short Circuit-Clear	Inverter switch short circuit cleared
N# PWM Sync Fail-Set	N# power module rectifier and inverter PWM sync signal abnormal
N# PWM Sync Fail-Clear	N# power module rectifier and inverter PWM sync signal restored to normal
N# Intelligent Sleep-Set	N# power module intelligent sleep activated
N# Intelligent Sleep-Clear	N# power module intelligent sleep deactivated
Manual Transfer to INV-Set	N# power module manually switched to inverter
N# Input Over Curr Tout-Set	N# power module input current limit timeout
N# Input Over Curr Tout-Clear	N# power module input current limit timeout cleared
N# No Inlet Temp. Sensor-Set	N# power module air inlet temperature sensor improper connection or open circuit
N# No Inlet Temp. Sensor-Clear	N# power module air inlet temperature sensor restored to normal
N# No Outlet Temp. Sensor-Set	N# power module air outlet temperature sensor improper connection or open circuit
N# No Outlet Temp. Sensor-Clear	N# power module air outlet temperature sensor restored to normal
N# Inlet Over Temp.-Set	N# power module air inlet overtemperature
N# Inlet Over Temp.-Clear	N# power module air inlet temperature restored to normal
N# Capacitor Time Reset-Set	N# power module capacitor accumulated operating time cleared
N# Fan Time Reset-Set	N# power module fan accumulated operating time cleared
Battery History Reset-Set	Battery history cleared
Bypass Fan Time Reset-Set	Bypass fan accumulated operating time cleared
Battery Over Temp.-Set	Battery overtemperature
Battery Over Temp.-Clear	Battery overtemperature cleared
Bypass Fan Expired-Set	Bypass fan maintenance interval reached

Event	Description
Bypass Fan Expired-Clear	Bypass fan maintenance interval cleared
N# Capacitor Expired-Set	N# power module capacitor maintenance interval reached
N# Capacitor Expired-Clear	N# power module capacitor maintenance interval cleared
N# Fan Expired-Set	N# power module fan maintenance interval reached
N# Fan Expired-Clear	N# power module fan maintenance interval cleared
N# INV IGBT Driver Block-Set	N# power module inverter drive signal blocked
N# INV IGBT Driver Block-Clear	N# power module inverter drive signal unblocked
Dust Filter Expired-Set	Dust filter maintenance interval reached
Dust Filter Expired-Clear	Dust filter maintenance interval cleared
Battery Expired-Set	Battery maintenance interval reached
Battery Expired-Clear	Battery maintenance interval cleared
BMS COMM. Error-Set	BMS communication failure
BMS COMM. Error-Clear	BMS communication restored to normal
CAN COMM. Error-Set	Monitoring module CAN communication failure
CAN COMM. Error-Clear	Monitoring module CAN communication restored to normal
BMS Cell Undervoltage-Set	Battery cell voltage low
BMS Cell Undervoltage-Clear	Battery cell voltage restored to normal
BMS Cell Overvoltage-Set	Battery cell voltage high
BMS Cell Overvoltage-Clear	Battery cell voltage restored to normal
BMS Cell Volt Differ Fail-Set	Cell voltage imbalance excessive
BMS Cell Volt Differ Fail-Clear	Battery cell voltage restored to normal
BMS Batt Low Temp.-Set	Battery ambient temperature low
BMS Batt Low Temp.-Clear	Battery ambient temperature restored to normal
BMS Batt Over Temp.-Set	Battery ambient temperature high
BMS Batt Over Temp.-Clear	Battery ambient temperature restored to normal
BMS Charge Inhibited-Set	Battery charging inhibited by the BMS system
BMS Charge Inhibited-Clear	Battery charging enabled by the BMS system
BMS Discharge Inhibited-Set	Battery discharging inhibited by the BMS system
BMS Discharge Inhibited-Clear	Battery discharging enabled by the BMS system
Wave Trigger-Set	Fault waveform captured
Bypass CAN Fail-Set	Monitoring module bypass CAN signal abnormal
Bypass CAN Fail-Clear	Monitoring module bypass CAN signal restored to normal
Bypass Power Fuse Fail-Set	Bypass power fuse open
Bypass Power Fuse Fail-Clear	Bypass power fuse normal
N# Firmware Error-Set	N# power module firmware version error
N# Firmware Error-Clear	N# power module firmware version updated
System Setting Error-Set	System setting data error
Bypass Over Temp.-Set	Bypass overtemperature
Bypass Over Temp.-Clear	Bypass temperature restored to normal
N# Module ID Duplicate-Set	N# power module ID duplicated with other modules
N# Module ID Duplicate-Clear	N# power module ID corrected
Electrolyte Leakage-Set	Battery leakage
Electrolyte Leakage-Clear	Battery leakage alarm cleared
Power Units Num. Error-Set	Power unit quantity abnormal
Power Units Num. Error-Clear	Power unit quantity abnormality cleared
Output Volt Abnormal-Set	Output voltage abnormal
Output Volt Abnormal-Clear	Output voltage restored to normal
TransformerOverTemp.-Set	Transformer overtemperature

Event	Description
TransformerOverTemp.-Clear	Transformer temperature restored to normal
SystemOverload-Set	System overload
SystemOverload-Clear	System restored to normal
SystemOverloadTimeout-Set	System overload timeout
SystemOverloadTimeout-Clear	System overload delay timeout cleared
Batt Low ProhibitDischarge-Set	Battery discharge inhibited
Batt Low ProhibitDischarge-Clear	Battery discharge enabled
Batt Fuse Failure-Set	Battery fuse open
Batt Fuse Failure-Clear	Battery fuse normal
LCD COMM. Fail-Set	LCD communication failure
LCD COMM. Fail-Clear	LCD communication restored to normal
Interface Board COMM. Fail-Set	Interface board communication failure
Interface Board COMM. Fail-Clear	Interface board communication restored
Input Breaker Close-Set	Input circuit breaker closed
Input Breaker Open-Set	Input circuit breaker open
Output Breaker Close-Set	Output circuit breaker closed
Output Breaker Open-Set	Output circuit breaker open
Bypass Breaker Close-Set	Bypass circuit breaker closed
Bypass Breaker Open-Set	Bypass circuit breaker open
AuxiliaryPowerFailure-Set	Auxiliary power failure
AuxiliaryPowerFailure-Clear	Auxiliary power restored to normal
Dry Contact Power Failure-Set	Dry contact power failure
Dry Contact Power Failure-Clear	Dry contact power restored to normal
N# Bus Low Voltage-Set	N# power module bus undervoltage
N# Bus Low Voltage-Clear	N# power module bus voltage restored to normal
N# Discharge Unbalance-Set	N# power module discharge current abnormal
N# Discharge Unbalance-Clear	N# power module discharge current restored to normal
N# INV Volt Detect Abnormal-Set	N# power module inverter voltage abnormal
N# INV Volt Detect Abnormal-Clear	N# power module inverter voltage restored to normal
N# SCI Power Transfer Fail-Set	N# power module SCI power transfer failure
N# SCI Power Transfer Fail-Clear	N# power module SCI power transfer restored to normal
N# Battery Relay Fail-Set	N# power module battery relay failure
N# Battery Relay Fail-Clear	N# power module battery relay restored to normal
SD Card Capacity Less-Set	SD card capacity insufficient
SD Card Capacity Less-Clear	SD card capacity normal
Battery CB Close-Set	Battery circuit breaker closed
Battery CB Open-Set	Battery circuit breaker open

 **Note:**

- In **Log**, text colors indicate different event states: Green represents a normal event; gray represents an event that has been cleared; yellow represents a warning; and red represents a fault.
- Generally, **Set** indicates that an event has occurred or that a corresponding operation has been performed; **Clear** indicates that the event has been resolved or the fault has been cleared.

### 5.2.4 Setting

On the home screen, tap the  button at the bottom of the touchscreen to access the screen shown in Figure 5-18.

Figure 5-18 Submenu under Setting



The **Setting** submenus are detailed in Table 5-6.

Table 5-6 Submenus under Setting

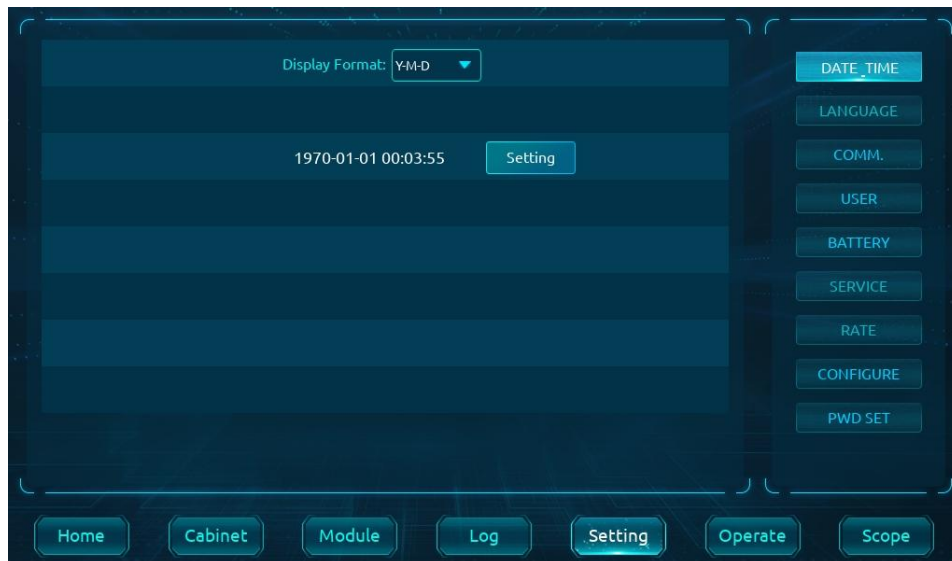
Submenu	Item	Description
DATE_TIME	Display format	Three formats: Y-M-D, M-D-Y, and D-M-Y.
	Setting	Set the date and time according to the selected date format.
LANGUAGE	Current language	Currently selected language.
	Available languages	Simplified Chinese, English, and other languages.
COMM.	Protocol Type	Select the protocol for USB, RS485, and SNMP ports, including SNT, Modbus, and CAN protocols.
	Communication Mode	Mainly used to set the Modbus communication mode, including ASCII and RTU.
	Baud Rate	Set the baud rate for the SNT, Modbus, and CAN protocols.
	Device Address	Select the communication device address.
	Parity	Select the parity mode for Modbus communication.
USER	Bypass Voltage Upper Limit	Maximum allowable bypass voltage (in percentage), including -10%, +15%, +20%, and +25%.
	Bypass Voltage Lower Limit	Minimum allowable bypass voltage (in percentage), including -10%, -15%, -20%, -30%, and -40%.
	Bypass Frequency Limit	Allowable operating range for bypass frequency, including $\pm 1\text{Hz}$ , $\pm 3\text{Hz}$ , and $\pm 5\text{Hz}$ .
	Output Voltage Adjustment (V)	Set the output voltage.

Submenu	Item	Description
	Title Set	Modify the three-phase display title in the software, including A-B-C, R-S-T, U-V-W, and L1-L2-L3.
	LCD Backlight Settings	Set the duration of the screen backlight.
	LOGO Time Set	Set the duration for which the LOGO is displayed on the screen.
BATTERY	Battery Type	Battery type, such as lead-acid or lithium-ion.
	Battery Cells Number	Set the number of batteries.
	Battery Capacity (Ah)	Set the battery capacity.
	Float Charge Voltage/Cell (V)	Set the float charge voltage for each cell.
	Boost Charge Voltage/Cell (V)	Set the boost charge voltage for each cell.
	PM Charge Curr Percent Limit (%)	Limit the power module charge current as a percentage of its rated capacity.
	Batt Maintenance Time Limit (Min)	Set the limit for battery discharge time.
	Reserved	Reserved setting.
	EOD Cell Voltage, @0.6C (V)	Set the EOD voltage of each cell when the battery string is discharged at 0.6C.
	EOD Cell Voltage, @0.15C (V)	Set the EOD voltage of each cell when the battery string is discharged at 0.15C.
	Batt Temp Compensate (mV/°C)	Set the battery temperature compensation coefficient for the charger to compensate for the voltage.
	Boost Temp. Compensate (mV/°C)	Set the boost charge temperature compensation coefficient for the charger to compensate for the voltage.
	Boost Charge Time Limit (H)	Set the boost charge time limit.
	Auto Boost Period (H)	Set the automatic boost charge period.
Auto Discharge Period (H)	Set the automatic discharge period.	
SERVICE	System Mode	Set the system mode, including single, parallel, single ECO, parallel ECO, parallel LBS, single super ECO, parallel super ECO, and self-aging. All modes can be selected except the self-aging mode.
	Parallel Number	Set the number of units in parallel.
	Cabinet ID	Set the cabinet ID.
	Slew Rate (Hz/Sec)	Set the frequency slew rate.
	Dust Filter Maint Period (Day)	Set the dust filter maintenance period.
	Synchronization Window (Hz)	Set the synchronization Window.
	Redundant Module Number	Set the number of redundant modules.
	Delay from Battery to Utility (Sec)	The delay for switching from battery to mains.
System Auto Start Mode After EOD	Set the system startup mode after EOD. Includes normal, bypass-only, and output disabled modes.	

Submenu	Item	Description
RATE	Cabinet Capacity (kVA)	Set the total capacity of the cabinet.
	Module Capacity (kVA)	Set the capacity of a single power module.
	Rated Input Voltage (V)	Set the rated input phase voltage.
	Rated Input Frequency (Hz)	Set the rated input frequency.
	Rated Output Voltage (V)	Set the rated output phase voltage.
	Rated Output Frequency (Hz)	Set the rated output frequency.
CONFIGURE	System configuration	System parameter settings.
PWD SET	Password Settings	Modify passwords for the current user and users with lower privilege levels. Use <b>Resume Password</b> to reset all account passwords to their default values.

**Setting** submenus are categorized into different privilege levels. The specific rules are as follows:

- **DATE\_TIME**, **LANGUAGE**, and **COMM.**: User-configurable; no password required.
- **USER**: Level 1 password required; restricted to professional personnel.
- **BATTERY** and **SERVICE**: Level 2 password required; restricted to after-sales service personnel.
- **RATE** and **CONFIGURE**: Factory-exclusive settings; Level 3 and Level 4 passwords required respectively.

**Note:**

- In **BATTERY** settings, C in **EOD Cell Voltage, @0.6C** and **EOD Cell Voltage, @0.15C** represent the battery capacity in ampere-hours. For example, for a 100Ah battery, C = 100A.
- Ensure that the **Battery Cells Number** and **Battery Capacity** settings match the actual battery string to prevent damage to the batteries.

### 5.2.5 Operate

On the home screen, tap the **Operate** button at the bottom of the touchscreen to access the screen shown in Figure 5-19.

Figure 5-19 Operate (FUNC COMMAND)

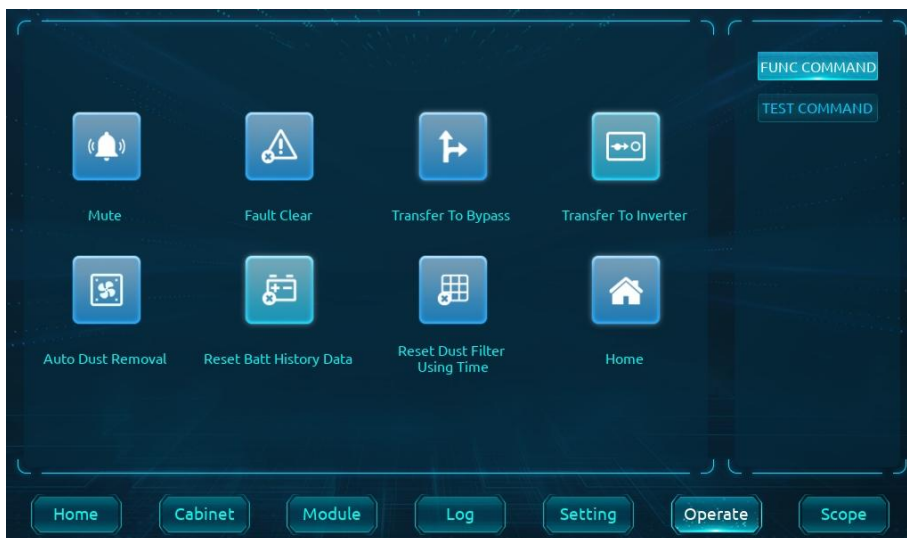

■ **Submenus under Operate**

Two submenus are available under **Operate**: **FUNC COMMAND** and **TEST COMMAND**. Tap the corresponding icon to access its screen, as shown in Figure 5-19 and Figure 5-20.

Figure 5-20 Operate (TEST COMMAND)

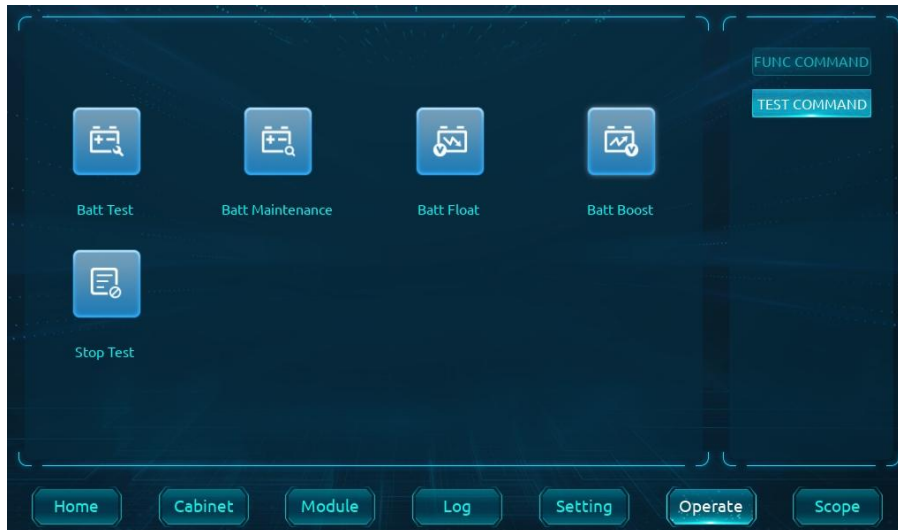

Submenu	Item	Description
FUNC COMMAND	Mute	Tap  or  to mute or unmute the alarm.
	Fault Clear	Tap  to clear the fault.
	Transfer to Bypass	Tap  or  to manually transfer to bypass mode or exit bypass mode.
	Transfer to Inverter	Tap  to transfer to the inverter.
	Auto Dust Removal	Tap  to start dust removal.
	Reset Batt History Data	Tap  to clear the historical battery data, including discharge times, operating days, and discharge hours.
	Reset Dust Filter Using Time	Tap  to reset the dust filter service time.
TEST COMMAND	Batt Test	Tap  to switch the system to battery discharge mode to check the battery status. The mains input and bypass input must be in normal status, and the battery capacity should be above 25%. After 20s of normal discharge, the battery self-test completes, and the system returns to normal mode.
	Batt Maintenance	Tap  to perform a partial discharge for battery charge-discharge maintenance. The mains input and bypass input must be in normal status, and the battery capacity should be above 25%. After discharging until the low battery voltage alarm is triggered, the maintenance discharge completes, and the system transfers back to normal operation.
	Batt Float	Tap  to manually start battery float charge.
	Batt Boost	Tap  to manually start battery boost charge.
	Stop Test	Tap  to manually terminate battery maintenance or battery self-test.

### 5.2.6 Scope

On the home screen, tap the **Scope** button at the bottom of the touchscreen to access the screen shown in Figure 5-21. The following submenus are available under **Scope: Output Voltage, Output Current, and Byp Volt**. Tap a submenu button to view the corresponding waveform. Yellow, green, and red represent Phase A, B, and C respectively, and the numbers below indicate the specific values.

Figure 5-21 Scope

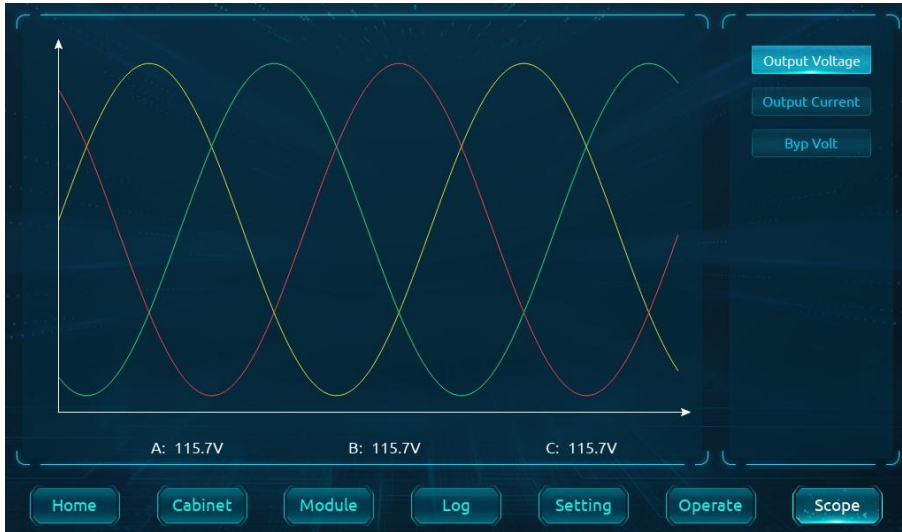

# 6 Commissioning

## 6.1 Starting up the UPS

Warning	
	<ul style="list-style-type: none"> <li>After the UPS installation is complete, the power-on and startup procedures must be performed by trained and qualified personnel to ensure it is started safely and correctly.</li> <li>Before startup, ensure all external switches are in the OFF position.</li> </ul>

### 6.1.1 Starting up in normal mode

The startup procedure for normal mode is as follows:

Step 1 Verify that all external switches are open.

Step 2 Close the external input switch, then close the output switch and bypass switch. The system begins initialization.

Step 3 After the touchscreen is powered on, three static white dots are displayed on the touchscreen at the top of the cabinet's front panel for about 40s, after which the home screen is displayed. When the power flow animation appears on the home screen, the system rectifier starts up, and the indicator in the submenu under Module turns green. Figure 6-1 shows the status after the rectifier starts up.

**Note:** The operation status icons are described in the table below.





Component	Icon	Component	Icon
Rectifier		Inverter	
Battery		Bypass	

Figure 6-1 Operating status after rectifier startup

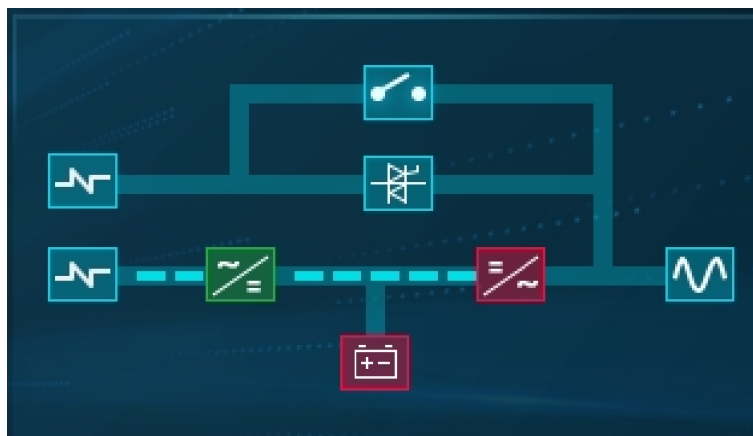

Table 6-1 Indicator status after rectifier startup

Indicator	State	Indicator	State
Rectifier	Green	Inverter	Red
Battery	Red	Bypass	Gray

Step 4 After the rectifier operates for approximately 30s, the rectifier indicator turns steady green, the static bypass switch is conducting, and the inverter starts up with its indicator turning red. Figure 6-2 shows the status after the inverter starts up.

Figure 6-2 Operating status after inverter startup

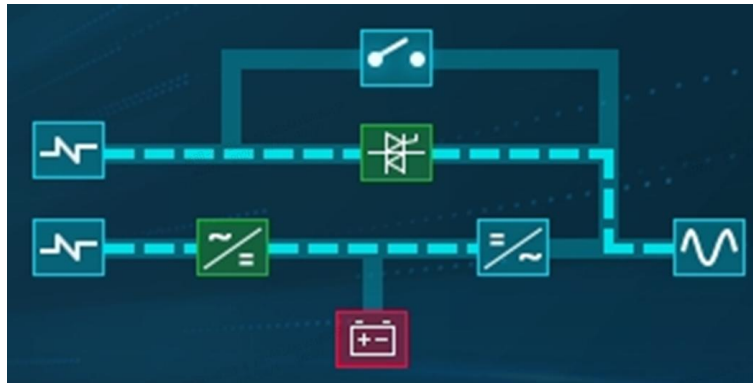

Table 6-2 Indicator status after inverter startup

Indicator	State	Indicator	State
Rectifier	Green	Inverter	Gray
Battery	Red	Bypass	Green

Step 5 After the inverter operates for approximately 60s, the UPS switches from bypass supply to inverter supply. The bypass indicator turns off, while the inverter and load indicators turn on. Figure 6-3 shows the status after the UPS transfers to the inverter supply.

Figure 6-3 Operation status under inverter supply

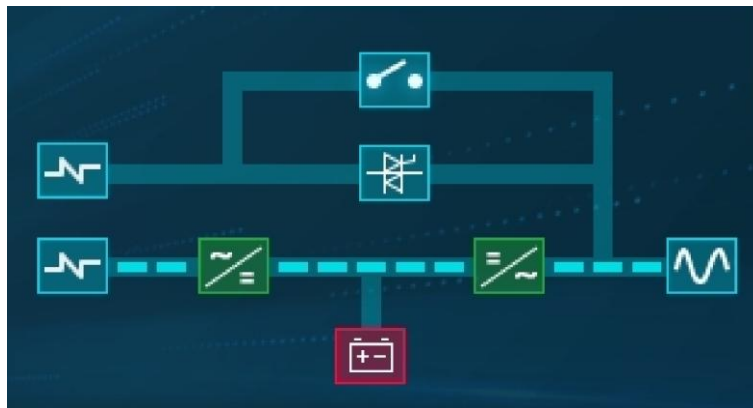

Table 6-3 Indicator status after the inverter starts supplying power

Indicator	State	Indicator	State
Rectifier	Green	Inverter	Green
Battery	Red	Bypass	Gray

Step 6 Close the external battery switch. After the battery indicator turns green, the UPS charges the battery and enters normal mode. The startup procedure is complete. Figure 6-4 shows the operating status after the battery and UPS enter normal operation.

Figure 6-4 Operating status after battery and UPS enter normal operation

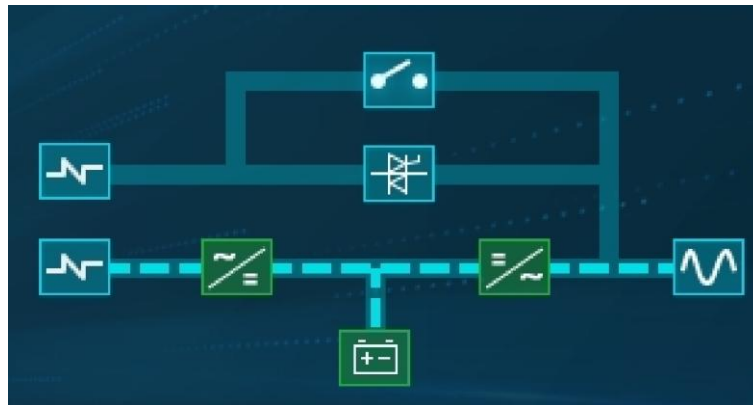

Table 6-4 Indicator status after battery and UPS enter normal operation

Indicator	State	Indicator	State
Rectifier	Green	Inverter	Green
Battery	Green	Bypass	Off

**Note:**

- At first power-up, **LANGUAGE**, **DATE\_TIME**, and **CONFIGURE** parameters can be configured via the **Setting** menu. On subsequent power-ups, the system retains the previous settings; if these parameters have already been configured, the system defaults to the existing settings.
- During startup, various events that occurred can be reviewed through the **History Log**.
- During startup, the operating status of each power module can be checked using its front panel keys.

### 6.1.2 Starting up in battery mode

Starting the UPS in battery mode is also known as a battery cold start (the battery cold start switch is located at the outer edge of the monitoring module). The startup procedure is as follows:

- Step 1 Verify that the batteries are properly connected and close the external battery switch.
- Step 2 Press and hold the red battery start button for more than 7s. The button location is shown in Figure 6-5. The system is now powered by the battery.

Figure 6-5 Battery cold start button location

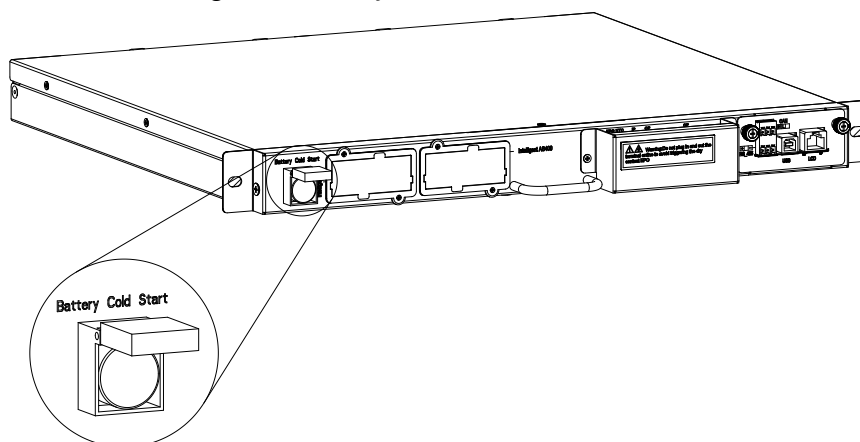

- Step 3 The system starts up by following the steps after Step 3 in section 6.1.1 Starting up in normal mode. After starting the rectifier, the system starts the inverter to complete the inverter output. The entire startup process takes about 60s, at which point the system operates in battery mode.

Step 4 Close the UPS output switch or external output switch to supply power to the load, completing the startup in battery mode.

## 6.2 Mode switching

### 6.2.1 From normal mode to battery mode

Open the input switch to disconnect the mains supply. The UPS will enter battery mode. To switch the UPS back to normal mode, wait a few seconds, then close the input switch to restore the mains supply. Approximately 10s later, the rectifier restarts automatically, and the inverter resumes power supply.

### 6.2.2 From normal mode to bypass mode

On the home screen, select  and tap **FUNC COMMAND > Transfer to Bypass**  to manually switch the system to bypass mode.

 **Note:**

- Before manually switching to bypass, ensure the bypass is operating normally. If the bypass is abnormal, the switch to bypass may fail.
- Ensure that the remaining power modules are not overloaded when shutting down the modules manually one by one.

### 6.2.3 From bypass mode to normal mode

On the home screen, select  and tap **FUNC COMMAND > Esc Bypass**  to manually switch the system to inverter mode.

### 6.2.4 From normal mode to maintenance bypass mode

When the UPS is operating in normal mode, follow the procedure below to switch the load from inverter output to maintenance bypass mode for maintenance.

The procedure is as follows:

- Step 1 Refer to the procedure in section 6.2.2 From normal mode to bypass mode. On the animated power flow diagram, the inverter indicator turns off. The buzzer sounds an alarm, the load switches to bypass mode, and the inverter shuts down.
- Step 2 Close the maintenance bypass switch. The load is then powered by both the maintenance bypass and the bypass.
- Step 3 Press the EPO switch on the control panel. At this point, the rectifier and battery stop operating, and the static bypass switch opens, while the maintenance bypass continues to power the load normally.
- Step 4 Open the mains input, bypass input, output, and battery switches. At this point, the monitoring module and bypass module or power modules can be extracted for maintenance.

 **Note:**

- Before performing the switching operation, check the LCD display to ensure that the bypass is functioning properly and that the inverter is synchronized with the bypass. Otherwise, the load may experience a brief power interruption.
- To maintain a power module, wait for approximately 10 minutes for the internal DC bus capacitor voltage to discharge to a safe level before opening the module.

### 6.2.5 From maintenance bypass mode to normal mode

When the UPS is operating in maintenance bypass mode, follow the procedure below to switch the system to normal mode:

- Step 1 Close the output switch, static bypass switch, and input switch in sequence. Wait approximately 50s until the static bypass switch is conducting and the bypass path shows animated flow on the power flow diagram. The load is powered by both the bypass and the maintenance bypass.
- Step 2 Open the maintenance bypass switch.
- Step 3 The rectifier starts automatically and completes startup after approximately 30s, with the animated flow displayed on the power flow diagram. Then, the inverter starts. After approximately 60s, the system switches to inverter supply, returning to normal operation.

**Note:** Ensure that the static bypass switch is conducting before opening the maintenance bypass switch; otherwise, a power interruption to the load will occur.

### 6.3 Performing a battery discharge test

When the battery is not used for an extended period, perform a discharge test. Two test methods are available:

Option 1: Manual discharge

On the home screen, select **Operate** and tap **TEST COMMAND > Batt Test**. The system enters battery mode. After discharging for approximately 20s, it switches back to normal mode.

Option 2: Automatic discharge

When automatic battery discharge is enabled, each discharge cycle lasts for the configured **Batt Maintenance Time Limit (Min)** or until the low battery voltage alarm is triggered. You also need to configure the **Auto Discharge Period (H)** and enable **Battery Auto Discharge**. Proceed as follows:

- Step 1 On the home screen, select **Setting**. Tap **CONFIGURE > Battery Auto Discharge** and tap **Confirm**.
- Step 2 On the **Setting** screen, tap **BATTERY**, set **Auto Discharge Period**, and tap **Confirm**.

**Note:**

- The battery test cycle is 30 to 120 days. The test is disabled by default.
- During the battery test, ensure the load is maintained between 20% and 100% of the rated battery capacity. If the load is below 20% of the rated battery capacity, automatic discharge maintenance cannot be performed.
- On the **Setting** screen, tap **Battery > Batt Maintenance Time Limit (Min)** and set a value from 1 to 60 minutes.

### 6.4 Shutting down the UPS completely

Danger	
	<ul style="list-style-type: none"> <li>• Hazardous voltage may still be present at the battery terminals even after the UPS is completely powered off. Verify with a multimeter.</li> <li>• After the UPS is powered off, wait for approximately 10 minutes for the internal DC bus capacitor voltage to fully discharge before performing maintenance.</li> </ul>

#### 6.4.1 With the load powered

This procedure applies when shutting down the UPS completely without interrupting load power.

For detailed steps, see section 6.2.4 From normal mode to maintenance bypass mode.

## 6.4.2 With the load unpowered

To completely shut down the UPS and disconnect power to the load, open all power switches, isolation switches, and circuit breakers. Follow these steps:

- Step 1 Press the EPO switch on the control panel to stop the operation of the rectifier, inverter, static bypass switch, and battery.
- Step 2 Open the external battery switch.
- Step 3 Open the mains input switch, bypass input switch, and output switch. At this point, all internal power supplies and the touchscreen are off.

## 6.5 EPO

The EPO switch on the UPS control panel is used to shut down the UPS in emergencies. Follow this procedure: Open the button cover. Press and hold the EPO switch for approximately 1s. The system will immediately shut down the rectifier and inverter, rapidly cut off power to the load (including inverter and bypass outputs), and stop charging or discharging the battery.

In the EPO state, if the mains input remains normal, the UPS control circuit remains powered. However, the load output is completely cut off. To completely disconnect the UPS from mains power, open the input switch and the external battery switch.

Figure 6-6 EPO switch location

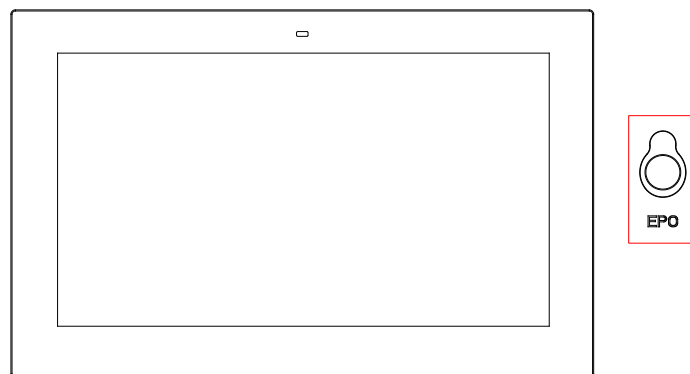

**Note:** Once the EPO switch is pressed, the UPS will shut down the rectifier, inverter, bypass switch, and battery, leaving the load unpowered. Use this switch with extreme caution. EPO does not affect the normal power supply to the load via the maintenance bypass (if a maintenance bypass switch is configured).

## 6.6 Resetting after an emergency or abnormal shutdown

If the UPS shuts down due to EPO activation, or conditions such as inverter overtemperature, overload, battery overvoltage, or DC bus overvoltage: First, check the alarm messages displayed on the touchscreen and clear the faults. Then, follow these steps to restore the UPS to normal operation:

- Step 1 On the home screen, select . Tap **FUNC COMMAND > Fault Clear** (see section 5.2.5 Operate for details) to exit the EPO or abnormal shutdown state.
- Step 2 After the rectifier automatically starts up, the system powers on normally.

**Note:**

- After the EPO button is pressed, the UPS mains input is disconnected, and the UPS shuts down completely. When the mains input is restored, the UPS starts up, enters bypass mode, and resumes output.
- The rectifier automatically starts 2 minutes after the overtemperature alarm disappears and the fault is

detected as cleared.

- If the maintenance bypass switch is closed and there is mains input, the UPS will provide output.

# 7 Maintenance

## 7.1 System maintenance

Caution:	
	<ul style="list-style-type: none"> <li>• The UPS system must be maintained only by trained and qualified personnel.</li> <li>• Only remove the monitoring module, bypass module, and power modules when the UPS is in maintenance bypass mode or completely powered off. Prevent the cabinet from tipping over during removal.</li> <li>• Before maintaining the power modules, the monitoring module, and the bypass module, use a multimeter to measure the voltage across DC bus capacitors, as well as the voltage between the part to be operated and the ground. Ensure the measured values are below hazardous voltages to ensure safety: below 36VDC for DC and below 30VAC for AC.</li> <li>• During UPS maintenance, the neutral (N) may remain live.</li> <li>• Wait at least 10 minutes after removing a power module before opening its cover for maintenance.</li> </ul>

### 7.1.1 Maintaining the power module

When the UPS is in normal mode and the bypass is normal, verify the cabinet load rate before maintaining any power modules. Calculate the total power of the modules to be removed, and determine whether there is any overload risk for the remaining power modules. If an overload risk is identified, manually switch the UPS system to bypass mode (see section 6.2.2 From normal mode to bypass mode) before proceeding with the following operations:

- Step 1 Shut down the power module. Move the slide switch on the right side of the module to the left (as shown in Figure 7-1). The power module will then automatically exit the system.
- Step 2 Wait for approximately 10 minutes. Remove the left and right trim strips from the power module front panel at the lower part of the cabinet. As shown in Figure 7-2, remove the fixing screws on both sides of the panel and pull the module out of the cabinet.
- Step 3 When the module is pulled halfway out, the anti-drop stopper on the right will stop it. Press the stopper to continue pulling the module out.
- Step 4 After completing maintenance, push the module into the cabinet (with an interval of at least 10s between each module). Then, tighten the screws on both sides.
- Step 5 Once the power module is secured in place, install the left and right trim strips on its front panel and move the slide switch to the right. The module will start automatically and join the system.

Figure 7-1 Power module location

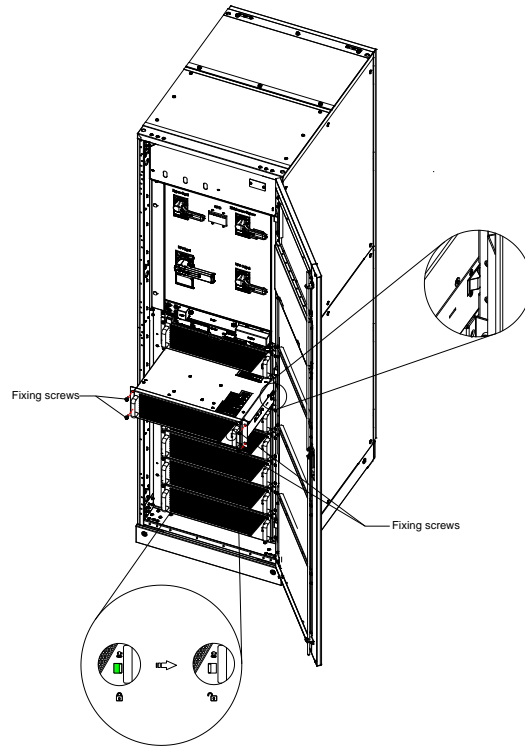
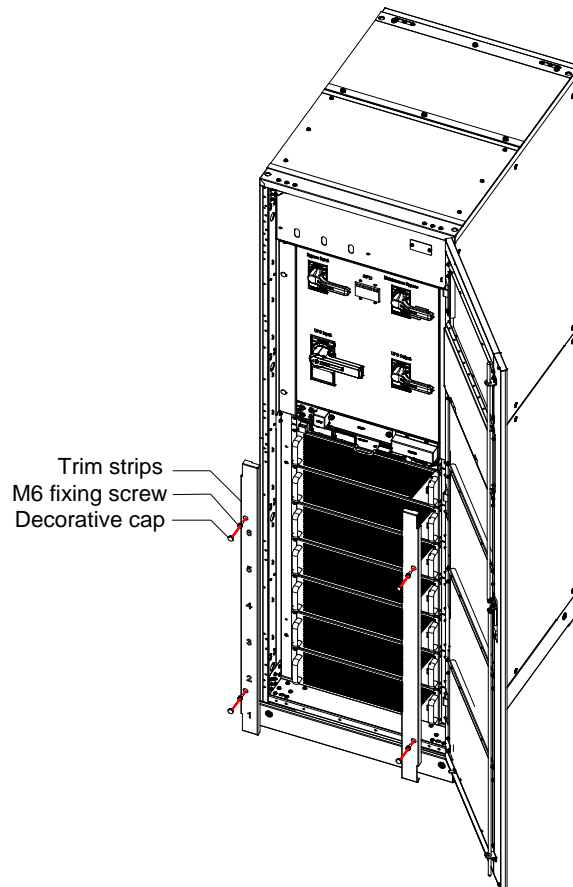

Figure 7-2 Trim strip location



**Note:** If the UPS system was manually switched to bypass mode, wait for 2 minutes after the power module starts before restoring the UPS system to normal mode. See section 6.2.3 From bypass mode to normal mode for details.

## 7.1.2 Maintaining the cabinet monitoring module and bypass module

When the UPS is operating in normal mode or the bypass is functioning normally, follow these steps to maintain or repair the monitoring module and the bypass module:

- Step 1 On the touchscreen, go to **Operate** > **FUNC COMMAND** and tap the **Transfer to Bypass** icon to manually switch the UPS to bypass mode. See section 6.2.2 From normal mode to bypass mode for details.
- Step 2 Close the maintenance bypass switch.
- Step 3 Open the external battery, mains input, bypass input, and output switches in sequence to switch the UPS to maintenance bypass mode.
- Step 4 Remove the left and right trim strips from the bypass module front panel at the lower part of the cabinet, as shown in Figure 7-2.
- Step 5 Remove the fixing screws on both sides of the monitoring module front panel, and disconnect the LCD ribbon cable from the front panel. As shown in Figure 7-3, pull the monitoring module out for maintenance.
- Step 6 Move the slide switch on the right side of the bypass module to the left, as shown in Figure 7-4. Remove the fixing screws on both sides of the bypass module front panel and pull the module outward. When pulled out halfway, the anti-drop stopper on the right will stop the module. Press the stopper to completely pull out the module for maintenance.
- Step 7 After completing maintenance, insert the monitoring module and the bypass module, and tighten the screws on both sides.
- Step 8 Install the left and right trim strips on the bypass module front panel.
- Step 9 Close the UPS output switch, bypass input switch, mains input switch, and battery switch in sequence.
- Step 10 After 2 minutes, the bypass path on the touchscreen shows an animated flow, indicating a normal bypass power supply.
- Step 11 Open the maintenance bypass switch. The inverter will start up automatically. The UPS will transfer to normal mode after 60s.

Figure 7-3 Monitoring module location

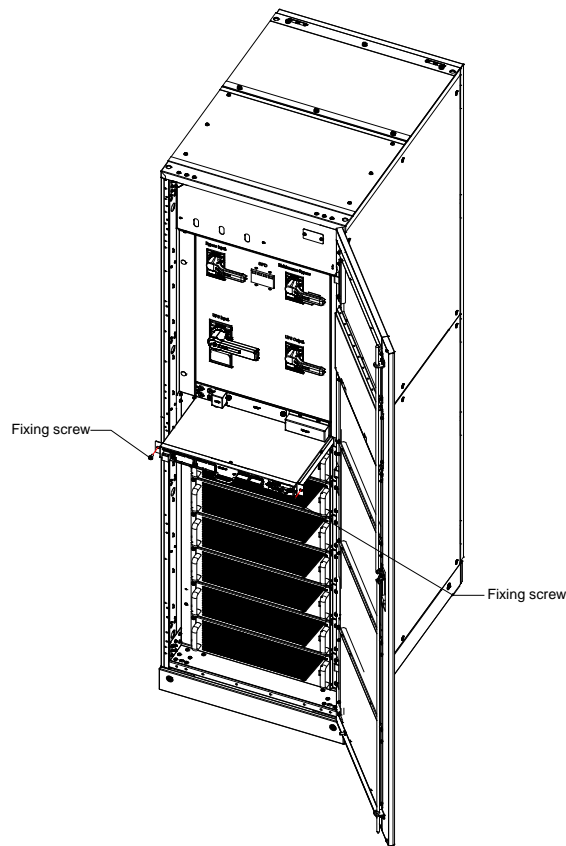
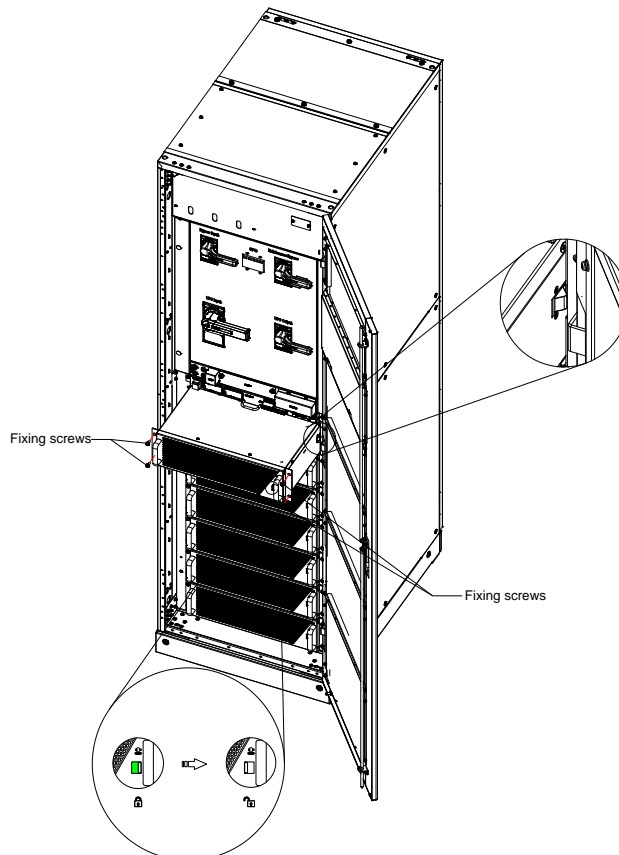

Figure 7-4 Bypass module location



**Note:**

- The bypass module is tightly fitted. Pull it firmly while rocking it from side to side several times. When the module is pulled halfway out, the anti-drop stopper on the right will stop it. Press the stopper to continue pulling the module out.
- When inserting the bypass module, push it into place firmly in a single, smooth motion. Failure to do so may cause poor contact, affecting the normal operation of both the module and the entire UPS system. The bypass module is correctly inserted when the fixing screws on both sides can be tightened and the module's mounting ears are flush against the cabinet posts.

## 7.2 Battery string maintenance

Under normal operating conditions, maintenance-free batteries do not require special maintenance. However, perform periodic inspections after a certain period of use to check for abnormalities such as an abnormal appearance, uneven voltage across batteries, or electrolyte leakage. If the batteries remain continuously charged for a long time, their activity may decline. Therefore, even when mains power is uninterrupted, perform periodic discharge tests to maintain battery health.

Strict adherence to standardized operating procedures during use can extend the service life of the batteries. Key factors impacting battery lifespan:

Item	Requirement
Installation conditions	Batteries must be installed in a clean, cool, ventilated, and dry environment. Avoid direct sunlight and any sources of radiant heat. <b>Note:</b> Verify battery specifications, capacity, and quantity during installation. Mixing batteries of different models or batches is strictly prohibited.
Ambient temperature	The operating temperature for batteries should be maintained at approximately 25°C.
Charge/discharge current	The discharge current range is typically 0.05C–3C. The optimal charge current for maintenance-free lead-acid batteries is around 0.1C. The charge current should not exceed 0.3C. Both excessively high and low charge currents can shorten battery life.
Charge voltage	Since the UPS battery operates in a standby mode, it remains charging when the mains power is normal and discharges only during a power outage. To extend battery life, the UPS charger typically uses a constant voltage and current-limiting charging method. Once the battery is fully charged, it switches to float charge mode, with the float voltage set to approximately 13.5V per cell. <b>Note:</b> If the charge voltage is too high, it will cause overcharging of the battery. If it is too low, the battery will be undercharged.
Depth of discharge	Battery cycle life is closely related to the Depth of Discharge (DoD). The deeper the battery is discharged, the fewer charge-discharge cycles it can sustain. Avoid deep discharge, especially under light-load or no-load conditions.

**Note:**

- Daily battery inspections are critical. Regularly check the battery terminals for tightness and monitor for any abnormal heating during operation.
- If the battery leaks or is damaged, it must be replaced. Dispose of damaged components in acid-resistant containers and follow local regulations for proper disposal.

# Appendix A Applicable standards

The UPS system complies with the following standards:

EN50091-1-1/IEC62040-1-1/AS 62040-1-1	General and safety requirements for use in operator access area
EN50091-2/IEC62040-2/AS 62040-2 (C3)	EMC requirements
YD/T2165-2017	Method of specifying the performance and test requirements

**Note:** The product standards in this table incorporate relevant compliance clauses from generic IEC and EN standards for safety (IEC/EN/AS60950), electromagnetic emission and immunity (IEC/EN/AS61000 series), and construction (IEC/EN/AS60146 series and 60950).

# Appendix B Dimensions

The dimensions of the UPS cabinet are shown in Figure B-1 (unit: mm).

Figure B-1 Dimensions

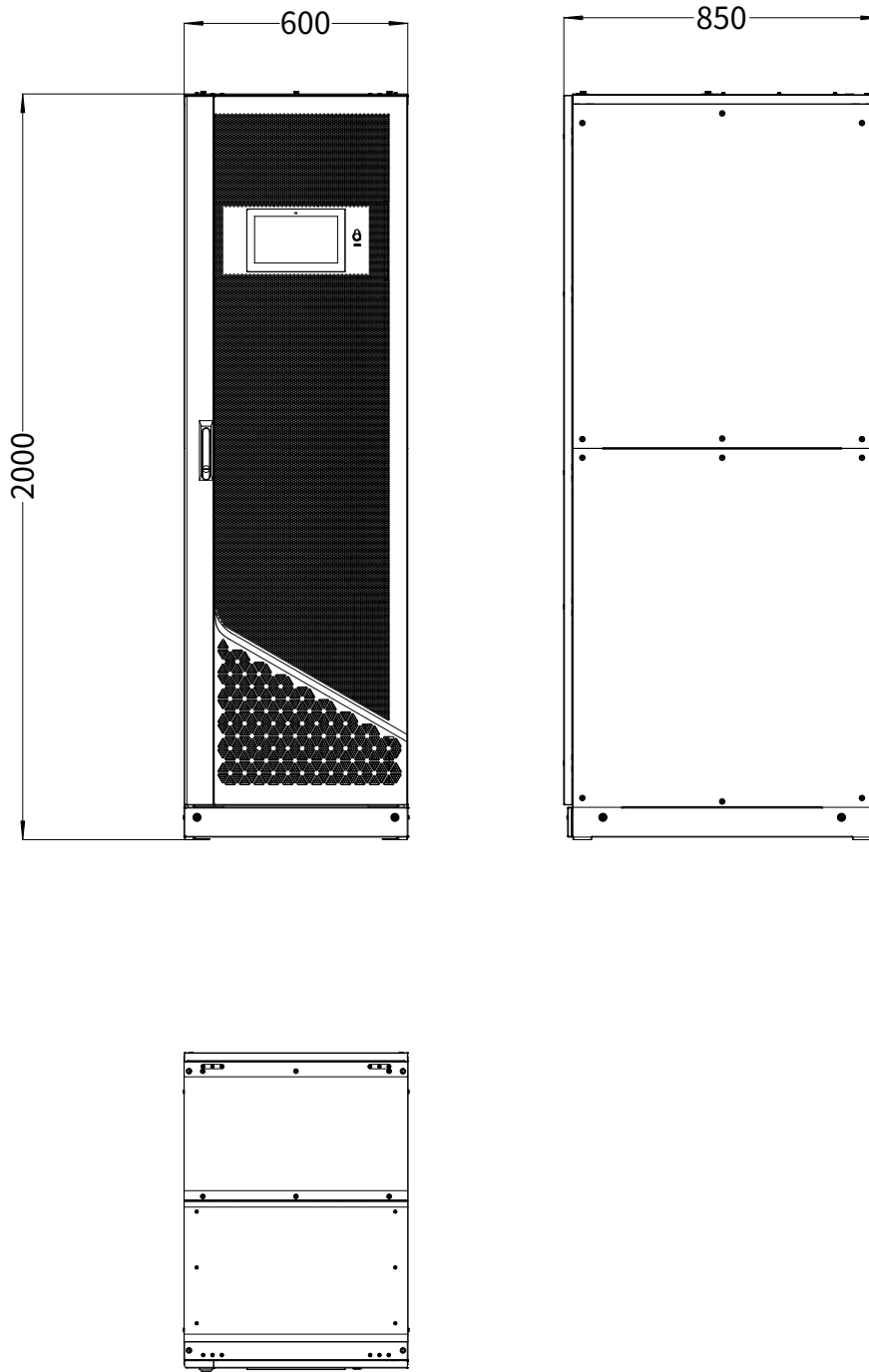

*Your Trusted Industry Automation Solution Provider*



**INVT Power System (Shenzhen) Co., Ltd.**

Address: INVT Guangming Technology Building, Songbai Road, Matian,  
Guangming District, Shenzhen, China



INVT mobile website



INVT e-manual



6 6 0 0 1 - 0 1 7 1 7