



Operation **Manual**

Goodrive100-PV Series
Solar Pump Inverter



SHENZHEN INVT ELECTRIC CO., LTD.

Contents

Contents	i
1 Safety precautions	1
1.1 Safety definition	1
1.2 Warning	1
1.3 Safety guidelines	2
1.3.1 Delivery and installation	2
1.3.2 Commissioning and running	3
1.3.3 Maintenance and component replacement	3
1.3.4 Scrap treatment	4
2 Product overview	5
2.1 Unpacking inspection	5
2.2 Product nameplate	5
2.3 Model designation code	5
2.4 Product specifications	6
2.5 Product ratings	6
3 Installation guidelines	9
3.1 Mechanical installation	9
3.1.1 Installation environment	9
3.1.2 Installation direction	10
3.1.3 Installation mode	11
3.2 Standard wiring	12
3.2.1 Main circuit terminals	12
3.2.2 Control circuit terminals	14
3.2.3 Input/output signal connection figure	17
4 Keypad operation guidelines	19
4.1 Keypad introduction	19
4.2 Keypad display	21
4.2.1 Displaying stopped-state parameters	21
4.2.2 Displaying running-state parameters	21
4.2.3 Displaying fault information	22
4.2.4 Editing function codes	22
4.3 Operation procedure	22
4.3.1 Modifying function codes	22
4.3.2 Setting a password for the inverter	23
4.3.3 Viewing inverter status	23
5 Commissioning guidelines	24
5.1 Check before running	24

5.2 Trial run.....	24
5.3 Parameter settings	24
5.4 Advanced settings	24
5.4.1 Water discharge speed PI adjustment.....	24
5.4.2 Special settings for single phase motors	25
6 Function parameter list.....	26
6.1 Function parameters related to control.....	26
P00 group Basic functions	26
P01 group Start and stop control	29
P02 group Parameters of motor 1	30
P04 group Space voltage vector control.....	31
P05 group Input terminals.....	35
P06 group Output terminals.....	36
P07 group Human-machine interface	38
P08 group Enhanced functions.....	45
6.2 Function parameters special for solar pump	45
P11 group Protection parameters	45
P14 group Serial communication.....	46
P15 group Functions special for solar inverter	48
P17 group Status viewing.....	58
P18 group Status viewing functions special for solar inverters	59
P19 group Functions for voltage boost (inverter module communicates with boost module through RS485 communication)	60
7 Fault diagnosis and solution.....	62
8 Communication protocol	67
8.1 Brief instruction to Modbus protocol	67
8.2 Application of the inverter	67
8.2.1 2-wire RS485.....	67
8.2.2 RTU mode.....	70
8.2.3 ASCII mode.....	74
8.3 Command code and communication data	75
8.3.1 RTU mode.....	75
8.3.2 ASCII mode.....	78
8.4 Data address definition.....	81
8.4.1 Function code address format rules	81
8.4.2 Description of other function addresses in Modbus.....	82
8.4.3 Fieldbus ratio values.....	85
8.4.4 Error message response	86
8.5 Read/Write operation example	88
8.5.1 Examples of reading command 03H.....	88

8.5.2 Examples of writing command 06H	89
8.5.3 Examples of continuous writing command10H.....	91
8.6 Common communication faults	93
Appendix A Options	94
A.1 Boost module	94
A.2 GPRS module and monitoring APP	95
A.3 Cable.....	96
A.3.1 Power cable.....	96
A.3.2 Control cable	96
A.4 Reactor.....	98
A.5 Filter	99
Appendix B Recommended solar module configuration	100
B.1 Recommended solar module configuration for solar pump inverters.....	100
B.2 Recommended solar module configuration for inverters with boost module	101
Appendix C Power frequency & PV switching solution	103
C.1 Solution introduction	103
C.1.1 QH100-PV switching module	103
C.1.2 Model selection reference for low-voltage apparatuses.....	105
C.2 IP54 protection-level inverters	106
C.3 Wiring description	108
C.4 Parameter setting method.....	109
Appendix D Dimension drawings	110
D.1 External keypad structure	110
D.2 Dimensions of 0.4-2.2kW models	111
D.3 Dimensions of 1.5-500kW models	113
Appendix E Further information	116
E.1 Product and service queries.....	116
E.2 Feedback of INVT inverter manuals.....	116
E.3 Document library on the Internet.....	116

1 Safety precautions

Please read this manual carefully and follow all safety precautions before moving, installing, operating and servicing the inverter. If ignored, physical injury or death may occur, or damage may occur to the devices.









If any physical injury or death or damage to the devices occurs for ignoring to the safety precautions in the manual, our company will not be responsible for any damages and we are not legally bound in any manner.

1.1 Safety definition





Danger:	Serious physical injury or even death may occur if not follow relevant requirements
Warning:	Physical injury or damage to the devices may occur if not follow relevant requirements
Note:	Physical hurt may occur if not follow relevant requirements
Qualified electricians:	People working on the device should take part in professional electrical and safety training, receive the certification and be familiar with all steps and requirements of installing, commissioning, operating and maintaining the device to avoid any emergency.

1.2 Warning

Warnings caution you about conditions which can result in serious injury or death and/or damage to the equipment, and advice on how to avoid the danger. Following warning symbols are used in this manual:

Symbols	Name	Instruction	Abbreviation
 Danger	Danger	Serious physical injury or even death may occur if not follow the relative requirements	
 Warning	Warning	Physical injury or damage to the devices may occur if not follow the relative requirements	
 Forbid	Electrostatic discharge	Damage to the PCBA board may occur if not follow the relative requirements	
 Hot sides	Hot sides	Sides of the device may become hot. Do not touch.	
Note	Note	Physical hurt may occur if not follow the relative requirements	Note

1.3 Safety guidelines

	<ul style="list-style-type: none"> ● Only qualified electricians are allowed to operate on the inverter. ● Do not carry out any wiring and inspection or changing components when the power supply is applied. Ensure all input power supply is disconnected before wiring and checking and always wait for at least the time designated on the inverter or until the DC bus voltage is less than 36V. Below is the table of the waiting time: <table border="1" data-bbox="234 331 926 496"> <thead> <tr> <th colspan="2">Inverter model</th> <th>Minimum waiting time</th> </tr> </thead> <tbody> <tr> <td>1PH 220V</td> <td>0.4kW-2.2kW</td> <td>5 minutes</td> </tr> <tr> <td>3PH 220V</td> <td>1.5kW-7.5kW</td> <td>5 minutes</td> </tr> <tr> <td>3PH 380V</td> <td>0.75kW-110kW</td> <td>5 minutes</td> </tr> <tr> <td>3PH 380V</td> <td>132kW-200kW</td> <td>15 minutes</td> </tr> </tbody> </table>	Inverter model		Minimum waiting time	1PH 220V	0.4kW-2.2kW	5 minutes	3PH 220V	1.5kW-7.5kW	5 minutes	3PH 380V	0.75kW-110kW	5 minutes	3PH 380V	132kW-200kW	15 minutes
Inverter model		Minimum waiting time														
1PH 220V	0.4kW-2.2kW	5 minutes														
3PH 220V	1.5kW-7.5kW	5 minutes														
3PH 380V	0.75kW-110kW	5 minutes														
3PH 380V	132kW-200kW	15 minutes														
	<ul style="list-style-type: none"> ● Do not refit the inverter unauthorized; otherwise fire, electric shock or other injury may occur. 															
	<ul style="list-style-type: none"> ● The base of the radiator may become hot during running. Do not touch to avoid hurt. 															
	<ul style="list-style-type: none"> ● The electrical parts and components inside the inverter are electrostatic. Take measurements to avoid electrostatic discharge during relevant operation. 															

1.3.1 Delivery and installation

	<ul style="list-style-type: none"> ● Please install the inverter on fire-retardant material and keep the inverter away from combustible materials. ● Do not operate on the inverter if there is any damage or components loss to the inverter. ● Do not touch the inverter with wet items or body, otherwise electric shock may occur.
--	---

Note:

- Select appropriate moving and installing tools to ensure a safe and normal running of the inverter and avoid physical injury or death. For physical safety, the erector should take some mechanical protective measurements, such as wearing safety shoes and working uniforms.
- Do not carry the inverter by its cover. The cover may fall off.
- Ensure to avoid physical shock or vibration during delivery and installation.
- Install away from children and other public places.
- The leakage current of the inverter may be above 3.5mA during operation. Ground with proper techniques and ensure the grounding resistor is less than 10Ω. The conductivity of

PE grounding conductor is the same as that of the phase conductor (with the same cross sectional area).

- (+) and (-) are DC power supply input terminals. R, S and T (L,N) are AC power supply input terminals. U, V and W are output terminals. Please connect the input power cables and motor cables with proper techniques; otherwise the damage to the inverter may occur.

1.3.2 Commissioning and running

	<ul style="list-style-type: none"> ● Disconnect all power supplies applied to the inverter before the terminal wiring and wait for at least the designated time after disconnecting the power supply. ● High voltage is present inside the inverter during running. Do not carry out any operation except for the keypad setting. ● The inverter cannot be used as "Emergency-stop device". ● If the inverter is used to break the motor suddenly, a mechanical braking device shall be provided.
--	---

Note:

- Do not switch on or off the input power supply of the inverter frequently.
- For inverters that have been stored for a long time, check and fix the capacitance and try to run it again before utilization.
- Cover the front board before running, otherwise electric shock may occur.



1.3.3 Maintenance and component replacement

	<ul style="list-style-type: none"> ● Only qualified electricians are allowed to perform the maintenance, inspection, and components replacement of the inverter. ● Disconnect all power supplies to the inverter before the terminal wiring. Wait for at least the time designated on the inverter after disconnection. ● Take measures to avoid screws, cables and other conductive materials to fall into the inverter during maintenance and component replacement.
--	---

Note:

- Please select proper torque to tighten screws.
- Keep the inverter, parts and components away from combustible materials during maintenance and component replacement.
- Do not carry out any isolation voltage-endurance test on the inverter and do not measure the control circuit of the inverter by megameter.

1.3.4 Scrap treatment

	<ul style="list-style-type: none">● There are heavy metals in the inverter. Deal with it as industrial effluent.
	<ul style="list-style-type: none">● When the life cycle ends, the product should enter the recycling system. Dispose of it separately at an appropriate collection point instead of placing it in the normal waste stream.

2 Product overview

2.1 Unpacking inspection

Check as follows after receiving products:

1.	Check that there are no damage and humidification to the package. If not, please contact with local agents or INVT offices.
2.	Check the information on the type designation label on the outside of the package to verify that the drive is of the correct type. If not, please contact with local dealers or INVT offices.
3.	Check that there are no signs of water in the package and no signs of damage or breach to the inverter. If not, please contact with local dealers or INVT offices.
4.	Check the information on the type designation label on the outside of the package to verify that the name plate is of the correct type. If not, please contact with local dealers or INVT offices.
5.	Check to ensure the accessories (including user's manual and control keypad) inside the device is complete. If not, please contact with local dealers or INVT offices.

2.2 Product nameplate

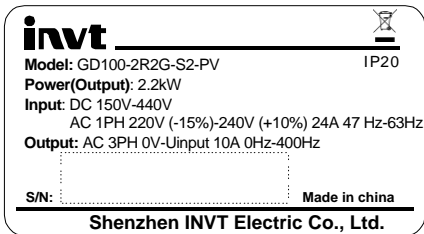

Note: This is a nameplate example of a standard inverter product. The CE/TUV/IP20 marking on the top right will be marked according to actual certification conditions.

2.3 Model designation code

A model designation code contains product information. You can find the model designation code on the inverter nameplate and simplified nameplate.

GD100 - 5R5G - 45 - PV

①

②

③ ④

⑤

Field	No.	Description	Content
Abbreviation of product series	①	Abbreviation of product series	GD is short for Goodrive.
Rated power	②	Power range + Load type	5R5G—5.5kW G—Constant torque load
Voltage class	③	Voltage class	4: AC 3PH 380V (-15%)–440(+10%) 2: AC 3PH 220V (-15%)–240(+10%) S2: AC 1PH 220V (-15%)–240(+10%) SS2: AC 1PH input/output 220V (-15%)–240(+10%)
Protection level	④	Protection level	Protection level. 5—IP54 Note: The protection level of a standard inverter is IP20, but this field is not displayed.
Industrial code	⑤	Industry code	PV: Photovoltaic water pump series products

2.4 Product specifications

Model	-SS2	-S2	-2	-4
AC input voltage (V)	220 (-15%)–240 (+10%) (1PH)		220 (-15%)–240 (+10%) (3PH)	380 (-15%)–440 (+10%) (3PH)
Max. DC voltage (V)	440	440	440	800
Start-up voltage (V)	200	200	200	300
Min. working voltage (V)	150	150	150	250
Recommended DC input voltage range (V)	200–400	200–400	200–400	300–750
Recommended MPP voltage (V)	330	330	330	550

2.5 Product ratings

Series	Model	Rated output power (kW)	Rated input current (A)	Rated output current (A)	Max. DC input current (A)
-SS2 model 1PH 220V	GD100-0R4G-SS2-PV	0.4	6.5	4.2	9
	GD100-0R7G-SS2-PV	0.75	9.3	7.2	9

Series	Model	Rated output power (kW)	Rated input current (A)	Rated output current (A)	Max. DC input current (A)
Input/output (0.4-2.2 kW)	GD100-1R5G-SS2-PV	1.5	15.7	10.2	12
	GD100-2R2G-SS2-PV	2.2	24	14	12
-S2 model 1PH 220V input (0.4-2.2 kW)	GD100-0R4G-S2-PV	0.4	6.5	2.5	9
	GD100-0R7G-S2-PV	0.75	9.3	4.2	9
	GD100-1R5G-S2-PV	1.5	15.7	7.5	12
	GD100-2R2G-S2-PV	2.2	24	10	12
-2 model 3PH 220V (1.5-7.5kW)	GD100-1R5G-2-PV	1.5	7.7	7.5	12
	GD100-2R2G-2-PV	2.2	11	10	12
	GD100-004G-2-PV	4	17	16	20
	GD100-5R5G-2-PV	5.5	25	20	30
	GD100-7R5G-2-PV	7.5	33	30	40
-4 model 3PH 380V (0.75-500kW)	GD100-0R7G-4-PV	0.75	3.4	2.5	9
	GD100-1R5G-4-PV	1.5	5.0	4.2	9
	GD100-2R2G-4-PV	2.2	5.8	5.5	12
	GD100-004G-4-PV	4.0	13.5	9.5	16.5
	GD100-5R5G-4-PV	5.5	19.5	14	23.9
	GD100-7R5G-4-PV	7.5	25	18.5	30.6
	GD100-011G-4-PV	11	32	25	39.2
	GD100-015G-4-PV	15	40	32	49
	GD100-018G-4-PV	18.5	47	38	50
	GD100-022G-4-PV	22	51	45	60
	GD100-030G-4-PV	30	70	60	81
	GD100-037G-4-PV	37	80	75	90
	GD100-045G-4-PV	45	98	92	130
	GD100-055G-4-PV	55	128	115	150
	GD100-075G-4-PV	75	139	150	200
	GD100-090G-4-PV	90	168	180	250
	GD100-110G-4-PV	110	201	215	300
	GD100-132G-4-PV	132	265	260	360
	GD100-160G-4-PV	160	310	305	430
	GD100-185G-4-PV	185	345	340	500
GD100-200G-4-PV	200	385	380	550	

Series	Model	Rated output power (kW)	Rated input current (A)	Rated output current (A)	Max. DC input current (A)
	GD100-220G-4-PV	220	430	425	480
	GD100-250G-4-PV	250	485	480	525
	GD100-280G-4-PV	280	545	530	600
	GD100-315G-4-PV	315	610	600	690
	GD100-355G-4-PV	355	625	650	760
	GD100-400G-4-PV	400	715	720	870
	GD100-450G-4-PV	450	840	820	970
	GD100-500G-4-PV	500	890	860	1100

3 Installation guidelines

The chapter describes the mechanical installation and electric installation.



- Only qualified electricians are allowed to carry out what described in this chapter. Please operate as the instructions in 1 Safety precautions. Ignoring these may cause physical injury or death or damage to the devices.
- Ensure the power supply of the inverter is disconnected during the operation. Wait for at least the time designated after the disconnection if the power supply is applied.
- The installation and design of the inverter should be complied with the requirement of the local laws and regulations in the installation site. If the installation infringes the requirement, our company will exempt from any responsibility. Additionally, if users do not comply with the suggestion, some damage beyond the assured maintenance range may occur.

3.1 Mechanical installation

3.1.1 Installation environment

The installation environment is the safeguard for a full performance and long-term stable functions of the inverter. Check the installation environment as follows:

Environment	Conditions
Installation site	Indoors.
Ambient temperature	<ul style="list-style-type: none"> ● -10°C–$+50^{\circ}\text{C}$, and air temperature change shall be less than $0.5^{\circ}\text{C}/\text{minute}$. ● When the ambient temperature exceeds 40°C, derate 1% for every increase of 1°C. ● Do not use the inverter when the ambient temperature exceeds 50°C. ● To improve reliability, do not use the inverter in the places where the temperature changes rapidly. ● When the inverter is used in a closed space such as control cabinet, use a cooling fan or air conditioner for cooling, preventing the internal temperature from exceeding the temperature required. ● When the temperature is too low, if you want to use the inverter that has been idled for a long time, it is required to install an external heating device before the use to eliminate the freeze inside the inverter. Otherwise, the inverter may be damaged.

Environment	Conditions
Humidity	<ul style="list-style-type: none"> ● The relative humidity (RH) of the air is less than 90%. ● Condensation is not allowed.
Storage temperature	-40°C—+70°C, with the air temperature change rate less than 1°C/minute.
Running environment	<p>Install the inverter in a place:</p> <ul style="list-style-type: none"> ● Away from electromagnetic radiation sources. ● Away from oil mist, corrosive gases and combustible gases. ● Without the chance for foreign objects such as metal powder, dust, oil and water to fall into the inverter (do not install the inverter onto combustible objects such as wood). ● Without radioactive substances and combustible objects. ● Without hazard gases and liquids. ● With low salt content. ● Without direct sunlight.
Pollution degree	Degree 2
Altitude	<ul style="list-style-type: none"> ● Lower than 1000m; ● When the altitude exceeds 1000m, derate 1% for every increase of 1°C. ● When the altitude exceeds 3000m, consult the local INVT dealer or office.
Vibration	Max. vibration acceleration: $5.8\text{m/s}^2(0.6\text{g})$
Installation direction	Install the inverter vertically to ensure good heat dissipation performance.

Note:

- The inverter must be installed in a clean and well-ventilated environment based on the IP level.
- The cooling air must be clean enough and free from corrosive gases and conductive dust.

3.1.2 Installation direction

The inverter may be installed on the wall or in a cabinet.

The inverter needs be installed in the vertical position. Check the installation site according to the requirements below. See **Appendix D Dimension drawings** for frame details.

3.1.3 Installation mode

(1) The inverters $\leq 2.2\text{kW}$ support wall mounting and rail mounting.

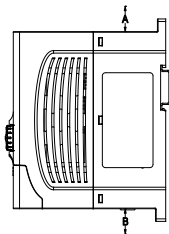

a) Wall mounting

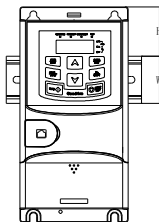

b) Rail mounting

Note: The minimum space of A and B is 100mm. H is 36.6mm and W is 35.0mm.

(2) The inverters $\geq 4\text{kW}$ support wall mounting and flange mounting.

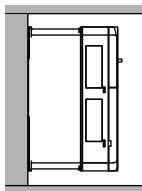

a) Wall mounting

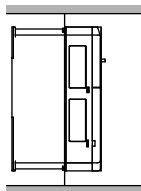

b) Flange mounting

1. Mark the locations of installation holes. For details about the holes, see the inverter dimension diagram in the appendix.
2. Fix the screws or bolts into the marked locations.
3. Lean the inverter against the wall.
4. Fasten the tightening screws on the wall.

3.2 Standard wiring

3.2.1 Main circuit terminals

The figure below shows the standard wiring of inverter.

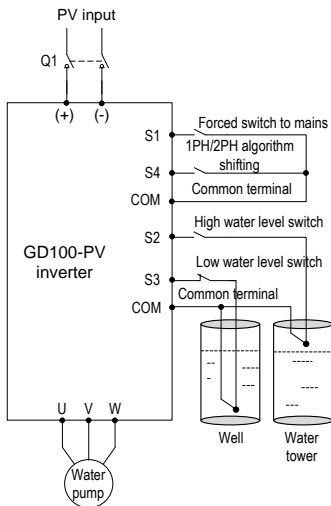

- The DC breaker Q1 must be installed as the protection switch for PV input.
- In parallel connection, the combination box special for PV must be used.
- When the distance between the PV input component and inverter exceeds 10 meters, Type-II surge protection devices must be configured at the DC side.
- When the distance between the pump and inverter exceeds 50 meters, it is recommended to configure output reactors. See A.4 Reactor for the output reactor model selection.
- The inverter automatically runs after being powered on. If parameters need to be set, follow the parameter setting instructions in 5 Commissioning guidelines.

Terminal	Name	Function
R, S, T (L, N)	AC input	3PH (1PH) AC input terminals, connected to the grid Note: Use the screws equipped with the inverter for wiring.
(+), (-)	PV input	Solar cell panel input terminals
U, V, W	Inverter output	3PH/1PH AC output terminals, connected to the pump motor Note: 1PH motors must connect to terminals U and W.
⊕	Safety grounding	Safety protection grounding terminal. Each inverter must be grounded

Description for -SS2 single-phase output models

1) Generally, the output terminals U and W of the inverter connect to the phase cables of the single-phase motor.

2) If the single-phase pump cannot be started, the two-phase control method must be used, and the start-up and running capacitors (if any) of the motor must be removed. The figure below shows the internal wiring of the common single-phase motor. In the figure, L1, L2, C1, and C2 indicate the running winding, start-up winding, running capacitor, and start-up capacitor. When the motor speed exceeds 75% of the rated speed, the start-up capacitor is switched off.

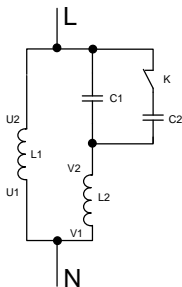

Internal wiring of the single-phase motor winding after removing the starting and running capacitor:

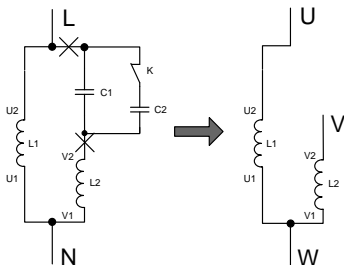

U1 and V1 are the common terminals of the windings. Connect them to the output terminal W of the solar pump inverter. Connect U2 to the output terminal U of the inverter. Connect V2 to the output terminal V of the inverter. (**Note:** Use the screws equipped with the inverter.) Connect S4 of the inverter to COM in short circuited manner.

3.2.2 Control circuit terminals

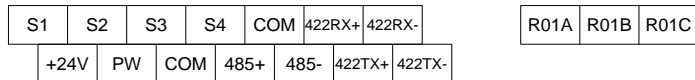

Figure 3-1 Control circuit terminal diagram for 2.2kW and lower inverters

Category	Terminal symbol	Terminal name	Terminal function
Power supply	24V	24V power supply	It provides the power of $24V \pm 10\%$ and maximum current of 200mA.
	COM	Common terminal	It functions as the working power supply of digital input and output or externally connects to the sensor power supply.
Digital input	S1	Forced switch to power frequency	Terminal feature parameters: 1. Internal impedance: $3.3k\Omega$ 2. Acceptable voltage input: 12–24V 3. Maximum input frequency: 1kHz S1: Forcible switch to power frequency (Switching-on indicates switching to power frequency, and switching-off indicates input controlled by the keypad.)
	S2	Full-water alarm	
	S3	Empty-water alarm	

Category	Terminal symbol	Terminal name	Terminal function
	S4	Single/two phase algorithm switching	S2: It connects to the high-water switch of the normally open contact by default. S3: It connects to the low-water switch of the normally closed contact. S4: A high electrical level corresponds to the single-phase algorithm. A low electrical level corresponds to the two-phase algorithm.
Communication	RS485+ RS485-	485 communication	485 communication terminals, using the Modbus protocol
	422TX+ 422TX- 422RX+ 422RX-	422 communication	Communication terminals special for the boost module.
Relay output	RO1A (ROA)	Normally open contact of relay 1	1. Contact capacity: 3A/AC250V, 1A/DC30V 2. They cannot be used for high frequency switch output. During the application of auto power frequency & PV switching, the AC input contactor coil is controlled by the normally closed contact of the relay.
	RO1B (ROB)	Normally closed contact of relay 1	
	RO1C (ROC)	Common terminal of relay 1	

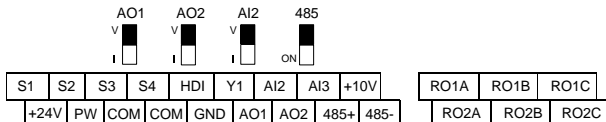

Figure 3-2 Control circuit terminal diagram for 4kW and higher inverters

Note: The rectangular black mark indicates the shorting cap or DIP switch ex-factory selection position.

Type	Terminal name	Function description	Technical specifications
Communication	485+	485 communication	485 communication interface
	485-		
Digital input/output	S1	Digital input	1. Internal impedance: 3.3kΩ 2. 12–30V voltage input is available 3. The terminal is the dual-direction input terminal 4. Max. input frequency: 1kHz
	S2		
	S3		
	S4		
	HDI	High frequency input channel	1. Except for S1–S4, this terminal can be used as high frequency input channel. 2. Max input frequency: 50kHz 3. Duty cycle: 30%–70%
	PW	Digital power supply	External power input terminal for digital input circuits Voltage range: 12–30V
Y1	COM	Digital output	1. Switch capacity: 50 mA/30V; 2. Range of output frequency: 0–1kHz.
			Common terminal of open collector output
24V power supply	+24V	24V power supply	External 24V±10% power supply and the maximum output current is 200mA. Generally used as the operation power supply of digital input and output or external sensor power supply.
	COM		
Analog input/output	+10V	External 10V reference power supply	10V reference power supply; Max. output current: 50 mA; As the adjusting power supply of the external potentiometer; Potentiometer resistance: 5kΩ above.
	AI2	Analog input	1. Input range: AI2 voltage and current can be chosen: 0–10V/0–20mA; AI3: -10V–+10V. 2. Input impedance: voltage input: 20kΩ; current input: 500Ω. 3. Voltage or current input can be set by dip switch. 4. Resolution: the minimum AI2/AI3 is 10mV/20mV when 10V corresponds to 50Hz.
	AI3		

Type	Terminal name	Function description	Technical specifications
	GND	Analog reference ground	Analog reference ground
	AO1	Analog output	1. Output range: 0–10V or 0–20mA. 2. The voltage or the current output is depended on the dip switch. 3. Deviation $\pm 1\%$, 25°C when full range.
	AO2		
Relay output	RO1A	Relay 1 NO contact	Relay output RO1 RO1A is in the NO state, RO1B is in the NC state, and RO1C is the common terminal.
	RO1B	Relay 1 NC contact	
	RO1C	Relay 1 common contact	
	RO2A	Relay 2 NO contact	Relay output RO2 RO2A is in the NO state, RO2B is in the NC state, and RO2C is the common terminal. Contact capacity: 3A/AC250V, 1A/DC30V
	RO2B	Relay 2 NC contact	
	RO2C	Relay 2 common contact	

3.2.3 Input/output signal connection figure

You can select the NPN/PNP mode and internal/external power through the U-shaped jumper. NPN internal mode is adopted by default.

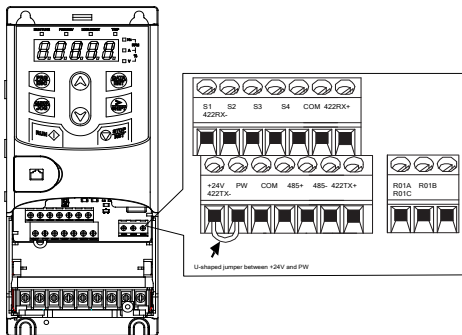

Figure 3–3 U-shaped jumper for 2.2kW and lower inverters

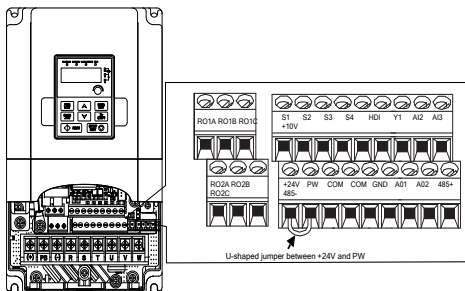

Figure 3-4 U-shaped jumper for 4kW and higher inverters

If input signal comes from NPN transistors, set the U-shaped jumper based on the power used according to the following figure.

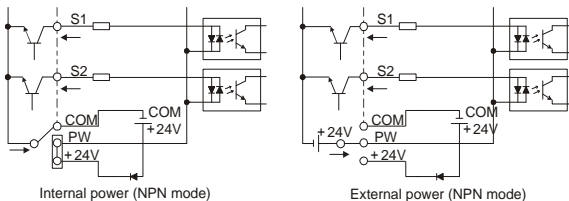

Figure 3-5 NPN mode

If input signal comes from PNP transistors, set the U-shaped jumper based on the power used according to the following figure.

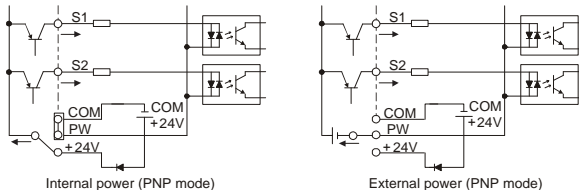

Figure 3-6 PNP mode

4 Keypad operation guidelines

4.1 Keypad introduction

The keypad is used to control the inverter, read inverter status, and set parameters. If you need to install the keypad on another position rather than on the inverter, use a keypad extension cable with a standard RJ45 crystal head.

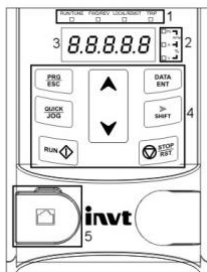

Figure 4-1 Keypad diagram for inverters of $\leq 2.2\text{kW}$

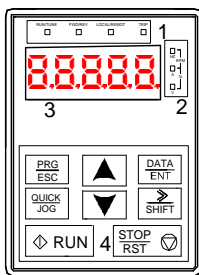
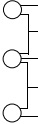









Figure 4-2 Keypad diagram for inverters of $\geq 4\text{kW}$

Note: The inverter models of $\leq 2.2\text{kW}$ support an optional external keypad, and the keypad of inverter models of $\geq 4\text{kW}$ can be installed on another device.

No.	Item	Description							
1	Status indicator	RUN/TUNE	Inverter running status indicator. Off: The inverter is stopped. Blinking: The inverter is autotuning parameters. On: The inverter is running.						
		FWD/REV	Forward or reverse running indicator. Off: The inverter is running forward. On: The inverter is running reversely.						
		LOCAL/REMOT	Indicates whether the inverter is controlled through the keypad, terminals, or communication. Off: The inverter is controlled through the keypad. Blinking: The inverter is controlled through terminals. On: The inverter is controlled through remote communication.						
		TRIP	Fault indicator Off: in normal state Blinking: in pre-alarm state On: in fault state						
2	Unit indicator	Mean the unit displayed currently							
			Hz	Frequency unit					
			RPM	Rotating speed unit					
			A	Current unit					
			%	Percentage					
	V	Voltage unit							
3	Digital display zone	Five-digit LED displays various monitoring data and alarm codes such as the frequency setting and output frequency.							
		Display	Means	Display	Means	Display	Means	Display	Means
		0	0	1	1	2	2	3	3
		4	4	5	5	6	6	7	7
		8	8	9	9	A	A	b	B
		C	C	d	D	E	E	F	F
		H	H	l	l	L	L	n	N
		n	n	o	o	P	P	r	r
		S	S	t	t	U	U	v	v
		.	.	-	-				

No.	Item	Description	
4	Keys		Programming key Press it to enter or exit level-1 menus or delete a parameter.
			Confirmation key Press it to enter menus in cascading mode or confirm the setting of a parameter.
			UP key Press it to increase data or move upward.
			DOWN key Press it to decrease data or move downward.
			Right-shifting key Press it to select display parameters rightward in the interface for the inverter in stopped or running state or to select digits to change during parameter setting.
			Run key Press it to run the inverter when using the keypad for control.
			Stop/Reset key Press it to stop the inverter that is running. The function of this key is restricted by P07.04. In fault alarm state, this key can be used for reset in any control modes.
			Multifunction shortcut key The function of this key is determined by P07.02.
5	Keypad interface	External keypad interface. When the keypad is valid, the local keypad and external keypad light up simultaneously.	

4.2 Keypad display



The inverter keypad displays information such as the stopped-state parameters, running-state parameters, and fault status, and allows you to modify function codes.

4.2.1 Displaying stopped-state parameters

When the inverter is in stopped state, the keypad displays stopped-state parameters, as shown in Figure 4-3.

When the inverter is in stopped state, the keypad displays 4 stopped-state parameters, including set frequency, bus voltage, input terminal status, and output terminal status. You can press  to shift parameters.

4.2.2 Displaying running-state parameters

After receiving a valid running command, the inverter enters the running state, and the keypad displays running-state parameters, with the  indicator on. The on/off state of the  indicator is determined by the actual running direction, as shown in Figure 4-3.

In the running state, there are 6 parameters that can be displayed. There are: running frequency, set frequency, bus voltage, output voltage, output current, and rotational speed.

You can press the **>>/SHIFT** key to shift parameters.

4.2.3 Displaying fault information

After detecting a fault signal, the inverter enters the fault alarm state immediately, the fault code blinks on the keypad, and the TRIP indicator is on. You can perform fault reset by using the **STOP/RST** key, control terminals, or communication commands.

If the fault persists, the fault code is continuously displayed.

4.2.4 Editing function codes

You can press the **PRG/ESC** key to enter the editing mode in stopped, running, or fault alarm state (if a user password is used, see the description of P07.00). The editing mode contains two levels of menus in the following sequence: Function code group or function code number → Function code setting. You can press the **DATA/ENT** key to enter the function parameter display interface. In the function parameter display interface, you can press the **DATA/ENT** key to save parameter settings or press the **PRG/ESC** key to exit the parameter display interface.



Figure 4-3 Status display

4.3 Operation procedure

You can operate the inverter by using the keypad. For details about function code descriptions, see the function code list.

4.3.1 Modifying function codes

The inverter provides three levels of menus, including:

- Function code group number (level-1 menu)
- Function code number (level-2 menu)
- Function code setting (level-3 menu)

Note: When performing operations on the level-3 menu, you can press the **PRG/ESC** or **DATA/ENT** key to return to the level-2 menu. If you press the **DATA/ENT** key, the set value of the parameter is saved to the control board first, and then the level-2 menu is returned, displaying the next function code. If you press the **PRG/ESC** key, the level-2 menu is returned directly, without saving the set value of the parameter, and the current function code is displayed.

If you enter the level-3 menu but the parameter does not have a digit blinking, the parameter cannot be modified due to either of the following reasons:

- It is read only. Read-only parameters include actual detection parameters and running record

parameters.

- It cannot be modified in running state and can be modified only in stopped state.

Example: Change the value of P00.01 from 0 to 1.

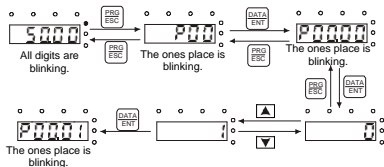

Note: When setting the value, you can press and + to modify the value.

Figure 4-4 Modifying a parameter

4.3.2 Setting a password for the inverter

The inverter provides password protection function to users. Set P07.00 to gain the password and the password protection becomes effective 1 minute later after retreating from the function code editing state. Press again to the function code editing state, "0.0.0.0.0" will be displayed. Unless using the correct password, you cannot enter it.

To disable the password protection function, you need only to set P07.00 to 0.

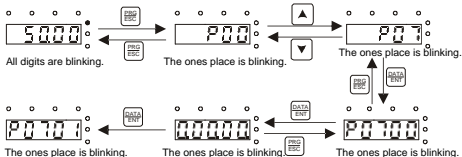

Note: When setting the value, you can press and + to modify the value.

Figure 4-5 Setting a password

4.3.3 Viewing inverter status

The inverter provides group P17 for status viewing. You can enter group P17 for viewing.

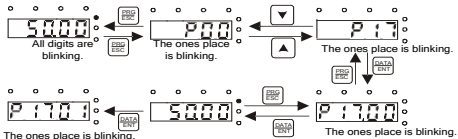

Note: When setting the value, you can press and + to modify the value.

Figure 4-6 Viewing a parameter

5 Commissioning guidelines



- Cut off all power supplies connected to the inverter before terminal wiring, and wait for at least the time designated on the inverter after disconnecting the power supplies.
- High voltage presents inside the inverter during running. Do not carry out any operation on the inverter during running except for keypad setup.
- By default, the inverter runs automatically after being powered on. If you need to set parameters, comply with the procedure described in this chapter.

5.1 Check before running

Ensure the following before powering on the inverter:

1. The inverter has been grounded reliably.
2. The wire connection is correct and reliable.
3. The AC/DC breaker is selected correctly.
4. The solar DC input voltage is within the range allowed by the inverter.
5. The motor type, voltage, and power match the inverter type, voltage, and power.

5.2 Trial run

Close the DC circuit breaker, and the inverter runs automatically after a delay of about 10s. Observe the water output of the pump. If the water output is normal, the trial run is successful; if the water output is small, run again after swapping the connection of any two motor wires.

5.3 Parameter settings

By default, the inverter runs automatically after being powered on. To set parameters, do as follows: If the inverter has not been powered on, power on the inverter, and press **QUICK/JOG** within 10s to enter the keypad-based control mode (**LOCAL/REMOTE** off). If the inverter has been powered on (Run indicator is on), press the **STOP/RST** key to enter the parameter setting interface. After the parameters are set, turn off and turn on the inverter power.

5.4 Advanced settings

Note: The default settings of the inverter can be adapted to most working conditions, and advanced settings are not required in most cases.

5.4.1 Water discharge speed PI adjustment

If you have higher requirements on the water discharge speed, you can adjust the PI parameters ([P15.06](#)–[P15.10](#)) appropriately. Setting the PI parameters to larger values will result in a faster water discharge speed, but the motor frequency fluctuates greatly; conversely, setting the PI parameters to smaller values will result in a slower water discharge speed, but the motor running frequency is relatively smooth.

5.4.2 Special settings for single phase motors

a) When the single phase motor is in poor running performance, you can adjust P04 group VF curve settings. Set [P04.00](#)=1 and set [P04.03](#)-[P04.08](#) to appropriate values according to commissioning conditions. Increase the voltage if the motor cannot start and decrease the voltage if the current is large.

b) When the light is normal and the system starts slowly, increase initial voltage differential value of [P15.28](#) appropriately.

c) For single phase motors with two-phase control (capacitor-removing):

① The max. voltage needs to be less than 1/1.6 of the bus voltage. It is recommended to set the rated voltage ([P02.04](#)) less than 200V, or limit the max. voltage output by multi-dot V/F curve.

② Observe the currents of the windings through [P17.38](#) and [P17.39](#), the switched current is the combination current of the two windings. The impedances of the windings are different, so the currents are different at the same voltage output.

③ [P04.35](#) can be used to change the output currents of the main and secondary windings. It is recommended that qualified engineers perform adjustment since the voltage adjustment is associated with motor design parameters. Otherwise, the motor performance may be impacted.

6 Function parameter list

"○" indicates that the value of the parameter can be modified when the inverter is in stopped or running state.

"◎" indicates that the value of the parameter cannot be modified when the inverter is in running state.

"●" indicates that the value of the parameter is detected and recorded, and cannot be modified.

Note: The inverter automatically checks and constrains the modification of parameters, which helps prevent incorrect modifications.

6.1 Function parameters related to control

P00 group Basic functions

Function code	Name	Description	Default	Modify
P00.00	Speed control mode	0: SVC 0 No need to install encoders. Applicable to scenarios with requirements for low frequency, great torque, high speed control accuracy. Relative to SVC mode 1, SVC mode 0 is more applicable to the scenarios requiring small power. 1: SVC mode 1 Applicable to high-performance scenarios, featuring high rotation and torque accuracy, without the need to install pulse encoders. 2: Space voltage vector control mode Applicable to scenarios without demanding requirements on control accuracy, such as fan and pump. One inverter can drive multiple motors. Note: Before using a vector control mode, enable the inverter to perform motor parameter autotuning first.	2	◎
P00.01	Channel of running commands	Used to select the channel of running inverter control commands. The inverter control commands include the start, stop, forward run, reverse run, jog, and fault reset commands.	1	○

Function code	Name	Description	Default	Modify
		<p>0: Keypad (LOCAL/REMOT off) The commands are controlled through keypad keys, such as the RUN and STOP/RST keys. The running direction can be changed through setting the multi-function shortcut key QUICK/JOG to FWD/REV shifting function (P07.02=3). In running state, you can press both RUN and STOP/RST to enable the inverter to coast to stop.</p> <p>1: Terminal (LOCAL/REMOT blinking) The running commands are controlled through forward rotation, reverse rotation, forward jogging, and reverse jogging of multi-function input terminals.</p> <p>2: Communication (LOCAL/REMOT on) The running commands are controlled by the upper computer in communication mode.</p>		
P00.03	Max. output frequency	Used to set the max. output frequency of the inverter. Pay attention to this parameter because it is the foundation of the frequency setting and the speed of acceleration (ACC) and deceleration (DEC). Setting range: P00.04 –400.00Hz	50.00Hz	⊙
P00.04	Upper limit of running frequency	<p>The upper limit of the running frequency is the upper limit of the output frequency of the inverter which is lower than or equal to the maximum frequency.</p> <p>When the set frequency is higher than the upper limit of the running frequency, the upper limit of the running frequency is used for running.</p> <p>Setting range: P00.05–P00.03 (Max. output frequency)</p>	50.00Hz	⊙
P00.05	Lower limit of running frequency	<p>The lower limit of the running frequency is that of the output frequency of the inverter.</p> <p>The inverter runs at the lower limit</p>	0.00Hz	⊙

Function code	Name	Description	Default	Modify
		frequency if the set frequency is lower than the lower limit. Note: Max. output frequency \geq Upper limit frequency \geq Lower limit frequency Setting range: 0.00Hz– P00.04 (Upper limit of running frequency)		
P00.11	ACC time 1	ACC time means the time needed if the inverter speeds up from 0Hz to the Max. output frequency (P00.03). DEC time means the time needed if the inverter speeds down from the Max. output frequency to 0Hz (P00.03).	Depend on mode	<input type="radio"/>
P00.12	DEC time 1	The inverter has four groups of ACC/DEC time which can be selected by P05. The factory default ACC/DEC time of the inverter is the first group. Setting range of P00.11 and P00.12 : 0.0–3600.0s	Depend on mode	<input type="radio"/>
P00.13	Running direction	0: Run at the default direction. The inverter runs in the forward direction. FWD/REV indicator is off. 1: Run at the opposite direction. The inverter runs in the reverse direction. FWD/REV indicator is on. Modify P00.13 to shift the rotation direction of the motor. This effect equals to the shifting the rotation direction by adjusting either two of the motor lines (U, V and W). The motor rotation direction can be changed by QUICK/JOG on the keypad. Refer to parameter P07.02 . Note: When the parameter is restored to the default value, the motor's running direction is restored to the default one. Exercise caution before using this function if the change of motor rotation direction is disallowed after commissioning.	0	<input type="radio"/>

Function code	Name	Description	Default	Modify
		Do not change the setting of the parameter because reverse running is not allowed in water pump application scenarios. 2: Disable reverse running. It can be used in some special scenarios where reverse running is disallowed.		
P00.15	Motor parameter autotuning	0: No operation 1: Rotation autotuning Comprehensive motor parameter autotuning. It is recommended to use rotation autotuning when high control accuracy is needed. 2: Static autotuning Used in scenarios where the motor cannot be disconnected from load. 3: Static autotuning 2 Empty-load current and mutual inductance are not autotuned.	0	⊙
P00.18	Function parameter restore	0: No operation 1: Restore default values 2: Clear fault records Note: After the selected operation is performed, the function code is automatically restored to 0. Restoring the default values may delete the user password. Exercise caution before using this function.	0	⊙

P01 group Start and stop control

Function code	Name	Description	Default	Modify
P01.08	Stop mode	0: Decelerate to stop. When a stop command takes effect, the inverter lowers output frequency based on the DEC mode and the defined DEC time; when the frequency drops to 0Hz, the inverter stops.	0	○

Function code	Name	Description	Default	Modify
		1: Coast to stop. When a stop command takes effect, the inverter stops output immediately. And the load coasts to stop according to mechanical inertia.		
P01.18	Terminal-based running command protection at power-on	0: The terminal running command is invalid at power-on. 1: The terminal running command is valid at power-on.	1	<input type="radio"/>
P01.21	Power-off restart selection	0: Disable restart 1: Enable restart	1	<input type="radio"/>

P02 group Parameters of motor 1

Function code	Name	Description	Default	Modify	
P02.00	Motor type	0: Asynchronous motor (AM) 1: Reserved	0	<input checked="" type="radio"/>	
P02.01	Rated power of AM	0.1–3000.0kW	Used to set AM parameters. To ensure the control performance, set P02.01 – P02.05 correctly according to the information on the nameplate of the AM. The inverter provides the parameter autotuning function. Whether parameter autotuning can be performed properly depends on the settings of the motor nameplate parameters. In addition, you need to configure a motor according to the standard	Depend on model	<input checked="" type="radio"/>
P02.02	Rated frequency of AM	0.01Hz–P00.03		50.00 Hz	<input checked="" type="radio"/>
P02.03	Rated speed of AM	1–36000rpm		Depend on model	<input checked="" type="radio"/>
P02.04	Rated voltage of AM	0–1200V		Depend on model	<input checked="" type="radio"/>

Function code	Name	Description		Default	Modify
P02.05	Rated current of AM	0.8–6000.0A	motor configuration of the inverter. If the power of the motor is greatly different from that of the standard motor configuration, the control performance of the inverter degrades significantly. Note: Resetting the rated power (P02.01) of the motor can initialize the parameters P02.02–P02.10.	Depend on model	<input checked="" type="radio"/>
P02.06	Stator resistance of AM	0.001–65.535Ω	After motor parameter autotuning is properly performed, the values of P02.06–P02.10 are automatically updated. These parameters are the benchmark parameters for high-performance vector control, directly affecting the control performance. Note: Do not modify these parameters unless it is necessary.	Depend on model	<input type="radio"/>
P02.07	Rotor resistance of AM	0.001–65.535Ω		Depend on model	<input type="radio"/>
P02.08	Leakage inductance of AM	0.1–6553.5mH		Depend on model	<input type="radio"/>
P02.09	Mutual inductance of AM	0.1–6553.5mH		Depend on model	<input type="radio"/>
P02.10	Non-load current of AM	0.1–6553.5A		Depend on model	<input type="radio"/>

P04 group Space voltage vector control

Function code	Name	Description	Default	Modify
P04.00	V/F curve setting	This group of function code defines the V/F curve of motor 1 to meet the needs of different loads. 0: Straight-line V/F curve, applicable to constant torque loads	4	<input checked="" type="radio"/>

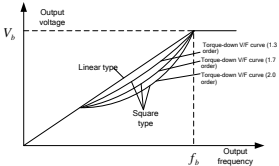
Function code	Name	Description	Default	Modify
		<p>1: Multi-dots V/F curve 2: Torque-down V/F curve (power of 1.3) 3: Torque-down V/F curve (power of 1.7) 4: Torque-down V/F curve (power of 2.0) Curves 2–4 are applicable to the torque loads such as fans and water pumps. You can adjust according to the characteristics of the loads to achieve best performance. 5: Customized V/F(V/F separation); in this mode, V can be separated from f and f can be adjusted through the frequency given channel set by P00.06 or the voltage given channel set by P04.27 to change the feature of the curve.</p> <p>Note: In the following figure, V_b is the motor rated voltage and f_b is the motor rated frequency.</p> 		
P04.01	Torque boost	In order to compensate for low-frequency torque characteristics, you can make some boost compensation for the output voltage. P04.01 is relative to the max. output voltage V_b .	0.0%	<input type="radio"/>
P04.02	Torque boost cut-off	P04.02 defines the percentage of cut-off frequency of manual torque boost to the rated motor frequency f_b . Torque boost can improve the low-frequency torque characteristics in space voltage vector control mode. You need to select torque boost based on the load. For example, larger load requires	20.0%	<input type="radio"/>

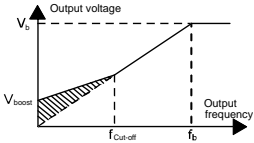
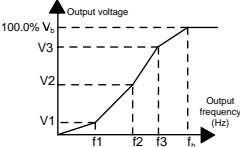
Function code	Name	Description	Default	Modify
		<p>larger torque boost, however, if the torque boost is too large, the motor will run at over-excitation, which may cause increased output current and motor overheating, thus decreasing the efficiency.</p> <p>When torque boost is set to 0.0%, the inverter uses automatic torque boost.</p> <p>Torque boost cut-off threshold: Below this frequency threshold, torque boost is valid; exceeding this threshold will invalidate torque boost.</p>  <p>Setting range of P04.01: 0.0%: (automatic) 0.1%–10.0%</p> <p>Setting range of P04.02: 0.0%–50.0%</p>		
P04.03	V/F frequency point 1 of motor 1	<p>If P04.00 =1, the user can set V//F curve by P04.03–P04.08.</p> <p>V/F is set to the motor load.</p> <p>Note: $V1 < V2 < V3$; $f1 < f2 < f3$. If the low-frequency voltage is high, overtemperature and burning may occur and the overcurrent stall and protection may occur to the inverter.</p>	0.00Hz	<input type="radio"/>
P04.04	V/F voltage point 1 of motor 1		00.0%	<input type="radio"/>
P04.05	V/F frequency point 2 of motor 1		00.00 Hz	<input type="radio"/>

Function code	Name	Description	Default	Modify
P04.06	V/F voltage point 2 of motor 1	Setting range of P04.03 : 0.00Hz– P04.05 Setting range of P04.04 : 0.0%–110.0% (rated voltage of motor1) Setting range of P04.05 : P04.03 – P04.07 Setting range of P04.06 : 0.0%–110.0% (rated voltage of motor1)	00.0%	<input type="radio"/>
P04.07	V/F frequency point 3 of motor 1	Setting range of P04.07 : P04.05 – P02.02 (rated frequency of motor1) or P04.05 – P02.16 (rated frequency of motor1) Setting range of P04.08 : 0.0%–110.0% (rated voltage of motor1)	00.00 Hz	<input type="radio"/>
P04.08	V/F voltage point 3 of motor 1		00.0%	<input type="radio"/>
P04.09	V/F slip compensation gain	Used to compensate for the motor rotating speed change caused by load change in the space voltage vector mode, and thus improve the rigidity of the mechanical characteristics of the motor. You need to calculate the rated slip frequency of the motor as follows: $\Delta f = f_b - n \cdot p / 60$ Of which, f_b is the rated frequency of the motor, corresponding to function code P02.01 . n is the rated rotating speed of the motor, corresponding to function code P02.02 . p is the number of pole pairs of the motor. 100.0% corresponds to the rated slip frequency Δf of the motor. Setting range: 0.0–200.0%	0.0%	<input type="radio"/>
P04.34	Two phase control selection of single-phase motor	Ones: Reserved Tens: Reversal of the secondary winding (V-phase) voltage 0: Not reversed; 1: Reversed Setting range: 0–0x11	0x00	<input checked="" type="radio"/>
P04.35	Voltage ratio of V-phase and U-phase	0.00–2.00	1.40	<input type="radio"/>

P05 group Input terminals

Function code	Name	Description	Default	Modify
P05.00	HDI input type	0: HDI is high-speed pulse input. See P05.49–P05.54. 1: HDI is digital input	1	☉
P05.01	S1 terminals function selection	0: No function 1: Run forward 2: Run reversely	42	☉
P05.02	S2 terminals function selection	3: Three-wire running control 4: Jog forward 5: Jog reversely 6: Coast to stop	43	☉
P05.03	S3 terminals function selection	7: Reset faults 8: Pause running 9: External fault input	44	☉
P05.04	S4 terminals function selection	10: Increasing frequency setting (UP) 11: Decreasing frequency setting (DOWN) 12: Cancel the frequency change setting	45	☉
P05.05	S5 terminals function selection	13: Shift between A setting and B setting 14: Shift between combination setting and A setting 15: Shift between combination setting and B setting	1	
P05.09	HDI terminals function selection	16: Multi-step speed terminal 1 17: Multi-step speed terminal 2 18: Multi-step speed terminal 3 19: Multi-step speed terminal 4 20: Multi-step speed pause 21: ACC/DEC time 1 22: ACC/DEC time 2 23: Simple PLC stop reset 24: Simple PLC pause 25: PID control pause 26: Traverse pause (stop at the current frequency) 27: Traverse reset (return to the center frequency) 28: Counter reset 29: Disable torque control	46	☉

Function code	Name	Description	Default	Modify										
		30: Disable ACC/DEC 31: Counter trigger 32: Reserved 33: Cancel the frequency change setting 34: DC brake 35: Reserved 36: Switch the running command channel to keypad 37: Switch the running command channel to terminal 38: Switch the running command channel to communication 39: Pre-magnetized command 40: Clear electricity consumption 41: Keep electricity consumption 42: Forcibly switches to power frequency (Switching-on indicates switching to power frequency; and switching-off indicates input controlled by the keypad.) 43: Full-water signal 44: Empty-water signal 45: Two-phase control mode of single-phase motor 46: PV digital input without the boost module (used for automatic switching) 47-63: Reserved												
P05.10	Input terminal polarity	0x000-0x10F <table border="1" style="width: 100%; text-align: center;"> <thead> <tr> <th>BIT8</th> <th>BIT3</th> <th>BIT2</th> <th>BIT1</th> <th>BIT0</th> </tr> </thead> <tbody> <tr> <td>HDI</td> <td>S4</td> <td>S3</td> <td>S2</td> <td>S1</td> </tr> </tbody> </table>	BIT8	BIT3	BIT2	BIT1	BIT0	HDI	S4	S3	S2	S1	0x000	☉
BIT8	BIT3	BIT2	BIT1	BIT0										
HDI	S4	S3	S2	S1										

P06 group Output terminals

Function code	Name	Description	Default	Modify
P06.03	RO1 output	0: Disable 1: Running 2: Running forward 3: Running reversely	30	○

Function code	Name	Description	Default	Modify				
P06.04	RO2 output	4: Jogging 5: Inverter in fault 6: Frequency level detection FDT1 7: Frequency level detection FDT2 8: Frequency reached 9: Zero-speed running 10: Upper limit frequency reached 11: Lower limit frequency reached 12: Ready for running 13: Pre-magnetizing 14: Overload prealarm 15: Underload prealarm 16: Simple PLC stage completed 17: Simple PLC cycle completed 18: Set count value reached 19: Defined count value reached 20: External fault is valid 21: Reserved 22: Running time reached 23: Modbus communication virtual terminal output 24–26: Reserved 27: In weak light 28–29: Reserved 30: Switches to PV input mode	5	○				
P06.05	Output terminal polarity selection	Used to set the polarity of output terminals. When a bit is 0, the output terminal is positive. When a bit is 1, the output terminal is negative. <table border="1" data-bbox="405 1108 741 1188" style="margin: 10px auto;"> <thead> <tr> <th>BIT1</th> <th>BIT0</th> </tr> </thead> <tbody> <tr> <td>RO2</td> <td>RO1</td> </tr> </tbody> </table> Setting range: 0–F	BIT1	BIT0	RO2	RO1	0	○
BIT1	BIT0							
RO2	RO1							
P06.10	RO1 switch-on delay	0.000–50.000s	10.000s	○				

Function code	Name	Description	Default	Modify
P06.11	RO1 switch-off delay	0.000–50.000s	10.000s	<input type="radio"/>
P06.12	RO2 switch-on delay	0.000–50.000s	0.000s	<input type="radio"/>
P06.13	RO2 switch-off delay	0.000–50.000s	0.000s	<input type="radio"/>

P07 group Human-machine interface

Function code	Name	Description	Default	Modify
P07.00	User password	<p>0–65535</p> <p>When you set the function code to a non-zero number, password protection is enabled.</p> <p>If you set the function code to 00000, the previous user password is cleared and password protection is disabled.</p> <p>After the user password is set and takes effect, you cannot enter the parameter menu if you enter an incorrect password. Please remember your password and save it in a secure place.</p> <p>After you exit the function code editing interface, the password protection function is enabled within 1 minute. If password protection is enabled, "0.0.0.0.0" is displayed when you press the PRG/ESC key again to enter the function code editing interface. You need to enter the correct user password to enter the interface.</p> <p>Note: Restoring the default values may delete the user password. Exercise caution before using this function.</p>	0	<input type="radio"/>

Function code	Name	Description	Default	Modify
P07.02	Function of QUICK/JOG	<p>0: No function</p> <p>1: Jogging running. Press QUICK/JOG to begin the jogging running.</p> <p>2: Switch the display state by the shifting key. Press QUICK/JOG to shift the displayed function code from right to left.</p> <p>3: Switch between forward rotations and reverse rotations. Press QUICK/JOG to shift the direction of the frequency commands. This function is only valid in the keypad commands channels.</p> <p>4: Clear UP/DOWN settings. Press QUICK/JOG to clear the set value of UP/DOWN.</p> <p>5: Coast to stop. Press QUICK/JOG to coast to stop.</p> <p>6: Switch command channels in sequence. Press QUICK/JOG key to switch the running command reference mode in sequence.</p> <p>7: Quick commissioning mode (based on non-factory parameters)</p> <p>Note: Press QUICK/JOG to shift between forward rotation and reverse rotation, the inverter does not record the state after shifting during powering off. The inverter will run according to parameter P00.13 during next powering on.</p>	6	◎
P07.03	Sequence of switching running-command channels by pressing QUICK/JOG	<p>When P07.02=6, set the sequence of switching running-command channels by pressing this key.</p> <p>0: Keypad→Terminal→Communication</p> <p>1: Keypad←→Terminal</p> <p>2: Keypad←→Communication</p> <p>3: Terminal←→Communication</p>	1	○
P07.04	Stop function validity of STOP/RST	Used to specify the stop function validity of STOP/RST . For fault reset, STOP/RST is valid in any conditions.	1	○

Function code	Name	Description	Default	Modify
		0: Valid only for keypad control 1: Valid both for keypad and terminal control 2: Valid both for keypad and communication control 3: Valid for all control modes		
P07.11	Boost module temperature	When the inverter is configured with the boost module, this function code displays the temperature of this module. This function code is valid only in the AC mode. This function code is invalid in the PV mode. -20.0–120.0°C		●
P07.12	Inverter module temperature	-20.0–120.0°C		●
P07.15	Inverter electricity consumption high-order bits	Used to display the electricity consumption of the inverter. Inverter electricity consumption =		●
P07.16	Inverter electricity consumption low-order bits	P07.15 *1000 + P07.16 Setting range of P07.15 : 0–65535kWh (*1000) Setting range of P07.16 : 0.0–999.9 kWh		●
P07.27	Current fault type	0: No fault		●
P07.28	Previous fault type	1: Inverter unit U-phase protection (OUt1) 2: Inverter unit V-phase protection (OUt2)		●
P07.29	Previous 2 fault type	3: Inverter unit W-phase protection (OUt3) 4: Overcurrent during acceleration (OC1) 5: Overcurrent during deceleration (OC2)		●
P07.30	Previous 3 fault type	6: Overcurrent during constant speed running (OC3)		●
P07.31	Previous 4 fault type	7: Overvoltage during acceleration (OV1) 8: Overvoltage during deceleration (OV2)		●
P07.32	Previous 5 fault type	9: Overvoltage during constant speed running (OV3) 10: Bus undervoltage (UV) 11: Motor overload (OL1) 12: Inverter overload (OL2) 13: Phase loss on input side (SPI) 14: Phase loss on output side (SPO) 15: Boost module overheat (OH1)		●

Function code	Name	Description	Default	Modify
		16: Inverter module overheat (OH2) 17: External fault (EF) 18: RS485 communication fault (CE) 19: Current detection fault (ItE) 20: Motor antotune fault (tE) 21: EEPROM operation error (EEP) 22: PID feedback disconnection (PIDE) 23: Braking unit fault (bCE) 24: Running time reached (END) 25: Electronic overload (OL3) 26 - 31:Reserved 32: To-ground short-circuit fault 1 (ETH1) 33: To-ground short-circuit fault 2 (ETH2) 34: Speed deviation fault (dEu) 35: Mal-adjustment (STo) 36:Underload fault (LL) 37: Hydraulic probe damage (tSF) 38: PV reverse connection fault (PINV) 39: PV overcurrent (PVOC) 40: PV overvoltage (PVOV) 41: PV undervoltage (PVLV) 42: Fault on 422 communication with the boost module (E-422) 43: Bus overvoltage detected on the boost module (OV) Note: Faults 38–40 are only detected in boost. The boost module stops working immediately after detecting a fault, while returning the fault information to the inverter module in the next data returning. Alarms: Light-weak pre-alarm (A-LS) Underload pre-alarm (A-LL) Full-water pre-alarm (A-tF) Empty-water pre-alarm (A-tL)		
P07.33	Running frequency at present fault		0.00Hz	●

Function code	Name	Description	Default	Modify
P07.34		Ramp reference frequency at present fault	0.00Hz	●
P07.35		Output voltage at present fault	0V	●
P07.36		Output current at present fault	0.0A	●
P07.37		Bus voltage at present fault	0.0V	●
P07.38		Max. temperature at present fault	0.0°C	●
P07.39		Input terminal state at present fault	0	●
P07.40		Output terminal state at present fault	0	●
P07.41		Running frequency at last fault	0.00Hz	●
P07.42		Ramp reference frequency at last fault	0.00Hz	●
P07.43		Output voltage at last fault	0V	●
P07.44		Output current at last fault	0.0A	●
P07.45		Bus voltage at last fault	0.0V	●
P07.46		Max. temperature at last fault	0.0°C	●
P07.47		Input terminal state at last fault	0	●
P07.48		Output terminal state at last fault	0	●
P07.49		Running frequency at 2nd-last fault	0.00Hz	●

Function code	Name	Description	Default	Modify
P07.50	Ramp reference frequency at 2nd-last fault		0.00Hz	●
P07.51	Output voltage at 2nd-last fault		0V	●
P07.52	Output current at 2nd-last fault		0.0A	●
P07.53	Bus voltage at 2nd-last fault		0.0V	●
P07.54	Max. temperature at 2nd-last fault		0.0°C	●
P07.55	Input terminal state at 2nd-last fault		0	●
P07.56	Output terminal state at 2nd-last fault		0	●
P07.57	Previous 6 fault type	0: No fault		●
P07.58	Previous 7 fault type	1: Inverter unit U-phase protection (OUt1) 2: Inverter unit V-phase protection (OUt2) 3: Inverter unit W-phase protection (OUt3) 4: Overcurrent during acceleration (OC1)		●
P07.59	Previous 8 fault type	5: Overcurrent during deceleration (OC2) 6: Overcurrent during constant speed running (OC3)		●
P07.60	Previous 9 fault type	7: Overvoltage during acceleration (OV1) 8: Overvoltage during deceleration (OV2)		●
P07.61	Previous 10 fault type	9: Overvoltage during constant speed running (OV3)		●
P07.62	Previous 11 fault type	10: Bus undervoltage (UV) 11: Motor overload (OL1)		●
P07.63	Previous 12 fault type	12: Inverter overload (OL2) 13: Phase loss on input side (SPI)		●
P07.64	Previous 13 fault type	14: Phase loss on output side (SPO) 15: Boost module overheat (OH1)		●
P07.65	Previous 14 fault type	16: Inverter module overheat (OH2) 17: External fault (EF)		●

Function code	Name	Description	Default	Modify
P07.66	Previous 15 fault type	18: RS485 communication fault (CE) 19: Current detection fault (ItE) 20: Motor antotune fault (tE)		●
P07.67	Previous 16 fault type	21: EEPROM operation error (EEP) 22: PID feedback disconnection (PIDE)		●
P07.68	Previous 17 fault type	23: Braking unit fault (bCE) 24: Running time reached (END)		●
P07.69	Previous 18 fault type	25: Electronic overload (OL3) 26–31:Reserved		●
P07.70	Previous 19 fault type	32: To-ground short-circuit fault 1 (ETH1) 33: To-ground short-circuit fault 2 (ETH2)		●
P07.71	Previous 20 fault type	34: Speed deviation fault (dEu) 35: Mal-adjustment (STo) 36:Underload fault (LL) 37: Hydraulic probe damage (tSF) 38: PV reverse connection fault (PINV) 39: PV overcurrent (PVOC) 40: PV overvoltage (PVOV) 41: PV undervoltage (PVLV) 42: Fault on 422 communication with the boost module (E-422) 43: Bus overvoltage detected on the boost module (OV) Note: Faults 38–40 are only detected in boost. The boost module stops working immediately after detecting a fault, while returning the fault information to the inverter module in the next data returning. Alarms: Light-weak pre-alarm (A-LS) Underload pre-alarm (A-LL) Full-water pre-alarm (A-tF) Empty-water pre-alarm (A-tL)		●

P08 group Enhanced functions

Function code	Name	Description	Default	Modify
P08.28	Auto fault reset count	0–10	5	<input type="radio"/>
P08.29	Auto fault reset interval	0.1–3600.0s	10.0s	<input type="radio"/>

6.2 Function parameters special for solar pump**P11 group Protection parameters**

Function code	Name	Description	Default	Modify
P11.00	Protection against phase loss	0x000–0x011 LED ones: 0: Software protection against input phase loss disabled 1: Software protection against input phase loss enabled LED tens: 0: Software protection against output phase loss disabled 1: Software protection against output phase loss enabled LED hundreds: Reserved 000–111	Depend on model	<input type="radio"/>
P11.01	Frequency decrease at sudden power loss	0: Disable 1: Enable	0	<input type="radio"/>
P11.02	Frequency decrease ratio at sudden power loss	Setting range: 0.00Hz– P00.03 /s If the bus voltage drops to the sudden frequency decreasing point due to the power loss of the grid, the inverter begins to decrease the running frequency according to P11.02 to make the motor in power generation state. The regenerative power	0.00Hz/s	<input type="radio"/>

Function code	Name	Description	Default	Modify						
		can maintain the bus voltage to ensure normal running of the inverter until the recovery of power.								
		<table border="1"> <tr> <td>Voltage class</td> <td>220V</td> <td>400V</td> </tr> <tr> <td>Frequency decrease point</td> <td>260V</td> <td>460V</td> </tr> </table>	Voltage class	220V	400V	Frequency decrease point	260V	460V		
Voltage class	220V	400V								
Frequency decrease point	260V	460V								

P14 group Serial communication

Function code	Name	Description	Default	Modify
P14.00	Local communication address	<p>Setting range: 1–247</p> <p>When the master writes the slave communication address to 0 indicating a broadcast address in a frame, all the slaves on the Modbus bus receive the frame but do not respond to it.</p> <p>Local communication address is unique in the communication network, which is the basis for point-to-point communication between the upper computer and the inverter.</p> <p>Note: The communication address of a slave cannot be set to 0.</p>	1	○
P14.01	Communication baud rate	<p>The function code is used to set the data transmission speed between upper computer and the inverter.</p> <p>0: 1200BPS 1: 2400BPS 2: 4800BPS 3: 9600BPS 4: 19200BPS 5: 38400BPS 6: 57600BPS</p> <p>Note: The baud rate set on the inverter must be consistent with that on the upper computer. Otherwise, the</p>	4	○

Function code	Name	Description	Default	Modify
		communication fails. A greater baud rate indicates faster communication.		
P14.02	Data bit check	The data format set on the inverter must be consistent with that on the upper computer. Otherwise, the communication fails. 0: No check (N, 8, 1) for RTU 1: Even check (E, 8, 1) for RTU 2: Odd check (O, 8, 1) for RTU 3: No check (N, 8, 2) for RTU 4: Even check (E, 8, 2) for RTU 5: Odd check (O, 8, 2) for RTU	1	<input type="radio"/>
P14.03	Communication response delay	0–200ms The function code indicates the communication response delay, that is, the interval from when the inverter completes receiving data to when it sends response data to the upper computer. If the response delay is shorter than the inverter processing time, the inverter sends response data to the upper computer after processing data. If the delay is longer than the inverter processing time, the inverter does not send response data to the upper computer until the delay is reached although data has been processed.	5	<input type="radio"/>
P14.04	RS485 communication timeout period	0.0 (invalid)–60.0s When the function code is set to 0.0, the communication timeout time is invalid. When the function code is set a non-zero value, the rectifier reports the "485 communication fault" (CE) if the communication interval exceeds the value. In general, the function code is set to 0.0. When continuous communication is required, you can set the function code	0.0s	<input type="radio"/>

Function code	Name	Description	Default	Modify
		to monitor communication status.		
P14.05	Transmission error processing	0: Report an alarm and coast to stop 1: Keep running without reporting an alarm 2: Stop in enabled stop mode without reporting an alarm (applicable only to communication mode) 3: Stop in enabled stop mode without reporting an alarm (applicable to any mode)	0	○
P14.06	Communication processing action	0x000–0x111 Ones place: 0: Respond to write operations. The inverter responds to read and write commands of the upper computer. 1: Not respond to write operations. The inverter responds only to the read commands of the upper computer. This mode can improve the communication efficiency. Tens place: Communication encryption 0: Communication password protection is invalid 1: Communication password protection is valid Hundreds place: User-defined communication command address 0: User-defined addresses specified by P14.07 and P14.08 are invalid 1: User-defined addresses specified by P14.07 and P14.08 are valid	0x000	○

P15 group Functions special for solar inverter

Function code	Name	Description	Default	Modify
P15.00	Solar inverter selection	0: Disable 1: Enable The value 0 indicates solar control is invalid,	1	◎

Function code	Name	Description	Default	Modify
		and this function group is not used. The value 1 indicates solar control is valid, this function group can be modified.		
P15.01	Vmpp voltage giving method	0: Voltage 1: Max. power tracking The value 0 indicates using the voltage giving method, the reference voltage is P15.02 , and it is a fixed value. The value 1 indicates the reference voltage is given by tracking the max. power. The reference voltage keeps changing until the system becomes stable. Note: This parameter is invalid when terminal function 43 is valid.	1	☉
P15.02	Vmpp voltage given through keypad	0.0–6553.5 Vdc When P15.01 is 0, this parameter determines the reference voltage. (During testing, the reference voltage value must be less than the PV input voltage. Otherwise, the system runs at the lower limit of frequency.)	250.0V	○
P15.03	PI control deviation limit	0.0–100.0% (100.0% corresponds to P15.02) PI adjustment is performed only when the ratio of the difference between the actual voltage and reference voltage to the reference voltage, which is $\text{abs}(\text{Actual voltage} - \text{Reference voltage}) * 100.0\% / (\text{Reference voltage})$, exceeds P15.03 . The default value is 0.0%. abs: absolute value	0.0%	○
P15.04	PID output upper limit frequency	P15.05 –100.0% (100.0% corresponds to P00.03) P15.04 is used to limit the Max. value of target frequency, and 100.0% corresponds to P00.03 . After PI adjustment, the target frequency cannot exceed the upper limit.	100.0%	○

Function code	Name	Description	Default	Modify
P15.05	PID output lower limit frequency	0.0%– P15.04 (100.0% corresponds to P00.03) P15.05 is used to limit the Min. value of target frequency, and 100.0% corresponds to P00.03 . After PI adjustment, the target frequency cannot be less than the lower limit.	20.0%	<input type="radio"/>
P15.06	KP1	0.00–100.00 Proportion coefficient 1 of the target frequency. A greater value indicates stronger effect and faster adjustment.	5.00	<input type="radio"/>
P15.07	KI1	0.00–100.00 Integral coefficient 1 of target frequency A greater value indicates stronger effect and faster adjustment.	5.00	<input type="radio"/>
P15.08	KP2	0.00–100.00 Proportion coefficient 2 of target frequency. A greater value indicates stronger effect and faster adjustment.	35.00	<input type="radio"/>
P15.09	KI2	0.00–100.00 Integral coefficient 2 of the target frequency. A greater value indicates stronger effect and faster adjustment.	35.00	<input type="radio"/>
P15.10	PI switching point	0.0–6553.5Vdc If the absolute value of PV voltage minus reference value is greater than P15.10 , P15.08 and P15.09 are used. Otherwise, P15.06 and P15.07 are used.	20.0V	<input checked="" type="radio"/>
P15.11	Water level control selection	0: Control through digital input 1: AI1(the water-level signal is input through AI1, not supported currently) 2: AI2 (the water-level signal is input through AI2, not supported currently) 3: AI3 (the water-level signal is input through AI3, not supported currently) If the function code is 0, the water-level signal is controlled by the digital input. See	0	<input checked="" type="radio"/>

Function code	Name	Description	Default	Modify
		<p>43 and 44 functions of S terminals in group P05 for detailed information. If the full-water signal is valid, the system will report the alarm (A-tF) and sleep after the time of P15.14. During the alarm, the full-water signal is invalid and the system will clear the alarm after the time of P15.15. If the empty-water signal is valid, the system will report the alarm (A-tL) and sleep after the time of P15.16. During the alarm, the empty-water signal is invalid and the system will clear the alarm after the time of P15.17.</p> <p>If the function code is 1 - 3, it is the reference of water-level control analog signal. For details, see P15.12 and P12.13.</p>		
P15.12	Full-water level threshold	<p>0.0–100.0%</p> <p>This code is valid when P15.11 water level control is based on analog input. If the detected water level control analog signal is less than the water level threshold P15.12 and keeps in the state after the delay time P15.14, the system reports A-tF and sleeps. If the delay time is not reached, the signal is bigger than the water level threshold, the time will be cleared automatically. When the measured water level control analog signal is less than the water level threshold, the delay time will be counted again. 0 is full water and 1 is no water.</p> <p>During the full-water alarm, if the detected water level signal is higher than the threshold of P15.12 and the delay counts, the alarm is cleared after the time set by P15.15 is reached in this continuous state continues. During the non-continuous application, the delay timing will clear automatically.</p>	25.0%	○

Function code	Name	Description	Default	Modify
P15.13	Empty-water level threshold	<p>0.0–100.0%</p> <p>This code is valid when P15.11 water level control is based on analog input. If the detected water level control analog signal is greater than the water level threshold P15.13 and keeps in the state after the delay time P15.16, the system reports A- tL and sleeps. If the delay time is not reached (that means non-continuous), the delay time is automatically cleared. When the detected water level control analog signal is less than the water level threshold, the delay counts. During the empty-water alarm, if the detected water level control analog signal is less than the water level threshold P15.13 and delay counts, the empty-water alarm is cleared after the delay time set by P15.17 in this continuous state. In the non-continuous state, the delay time is automatically cleared.</p>	75.0%	○
P15.14	Full-water level delay	<p>0–10000s</p> <p>Time setting on full-water level delay. (This parameter is still valid for digital full-water signal.)</p>	5s	○
P15.15	Full-water level wake-up delay	<p>0–10000s</p> <p>Time setting on full-water level wake-up delay. (This parameter is still valid for digital full-water signal.)</p>	20s	○
P15.16	Empty-water level delay	<p>0–10000s</p> <p>Time setting on empty-water level delay. (This parameter is still valid for digital empty-water signal.)</p>	5s	○
P15.17	Empty-water level wake-up delay	<p>0–10000s</p> <p>Time setting on empty-water level wake-up delay. (This parameter is still valid for digital empty-water signal.)</p>	20s	○

Function code	Name	Description	Default	Modify
P15.18	Hydraulic probe damage	0.0–100.0% If P15.18 is 0.0%, it indicates P15.18 is invalid. If P15.18 is not 0.0%, when the detected water level control analog signal is greater than the value set in P15.18 , the (tSF) fault is reported and the inverter stops.	0.0%	☉
P15.19	Water pump run time in underload state	0.0–1000.0s Duration in which the water pump runs in underload state. In continuous underload condition, the underload alarm (A-LL) is reported when the run time is reached.	60.0s	○
P15.20	Current detection value at underload running	0.0%: Automatic detection on underload 0.1–100.0% A value rather than 0.0% indicates it is determined by P15.20. 100.0% corresponds to the motor rated current. When the absolute value of target frequency minus ramp frequency is less than or equal to P15.22 (lagging frequency threshold): If the actual current value at the actual frequency is continuously less than P15.20, the system reports the underload fault with a delay specified by P15.19. Otherwise, the system runs properly. In the non-continuous situation, the delay counter is automatically cleared.	00.00%	○
P15.21	Underload reset delay	0.0–1000.0s Underload reset delay. In underload state, the counting on the underload run time and that on the underload reset delay are performed synchronously. Generally, the value needs to be greater than P15.19 so that the system can report the underload alarm when the underload run time is reached and then reset can be performed when the time P15.21–P15.19 elapsed. If the value of	120.0s	○

Function code	Name	Description	Default	Modify
		P15.21 is the same as that of P15.19, auto reset is performed at the same time as the underload alarm is reported.		
P15.22	Lagging frequency threshold	0.00–200.00Hz P15.22 is the lagging frequency threshold, used to determine the underload run condition. Currents are compared only when the absolute value of target frequency minus ramp frequency is continuously less than or equal to this parameter.	0.30Hz	○
P15.23	Weak-light delay	0.0–3600.0s Time setting on weak-light delay. When the output frequency is less than or equal to the PI output frequency lower limit and the delay counting is started, which reaches the weak-light delay time, the system reports the weak-light alarm (A-LS) and then sleeps. In the non-continuous situation, the delay counter is automatically cleared. Note: <ul style="list-style-type: none"> When the bus voltage is lower than the undervoltage point or the PV voltage is lower than 70V, the system directly reports the weak-light alarm without any delay. If P15.32=0, in weak-light condition, the system automatically switch to the power-frequency input mode. 	100.0s	○
P15.24	Weak-light wake-up delay	0.0–3600.0s Time setting on weak-light wake-up delay. If the weak-light pre-alarm is reported, the system clears the pre-alarm with the weak-light wake-up delay and then re-enters the running state. When P15.32 =0, if the PV voltage is greater than P15.34 , the system switches from the power-frequency input mode to the PV input mode with the weak-light wake-up delay.	300.0s	○

Function code	Name	Description	Default	Modify															
P15.25	Initial actual reference voltage display	0.0–2000.0V	0	●															
P15.26	Min. reference voltage in max. power tracking	0.00.0 po Used to set the min. reference voltage in max. power tracking. Min. reference voltage in max. power tracking = (Open-circuit voltage of photovoltaic panels) * P15.26 . Open-circuit voltage of photovoltaic panels = P15.25 + P15.28 Track the max. power in the range of Min. reference voltage in max. power tracking– P15.27 . P15.27 must be greater than the min. reference voltage. A smaller difference between them indicates a smaller range, which means faster tracking. The voltage corresponding to the max. power must be within the range. P15.26 and P15.27 must be adjusted according to the site situation.	0.70	○															
P15.27	Max. reference voltage in max. power tracking	Min. reference voltage in max. power tracking– P15.31 It is the max. voltage tracked when MPPT max. power tracking is valid. The factory value depends on the model. <table border="1" data-bbox="384 955 755 1199"> <thead> <tr> <th>Model</th> <th>Max. voltage reference</th> <th>Max. Vmppt</th> </tr> </thead> <tbody> <tr> <td>-SS2</td> <td>400</td> <td>400</td> </tr> <tr> <td>-S2</td> <td>400</td> <td>400</td> </tr> <tr> <td>-2</td> <td>400</td> <td>400</td> </tr> <tr> <td>-4</td> <td>750</td> <td>750</td> </tr> </tbody> </table>	Model	Max. voltage reference	Max. Vmppt	-SS2	400	400	-S2	400	400	-2	400	400	-4	750	750	400.0V	○
Model	Max. voltage reference	Max. Vmppt																	
-SS2	400	400																	
-S2	400	400																	
-2	400	400																	
-4	750	750																	
P15.28	Adjustment of initial reference voltage	0.0–200.0V MPPT starts to be disturbed from the initial reference voltage. Initial reference voltage = PV voltage – P15.28	5.0V	○															

Function code	Name	Description	Default	Modify
P15.29	Auto adjustment interval of Vmppt upper/lower limit	0.0–10.0s When P15.29 = 0.0, auto adjustment of Vmppt upper/lower limit is invalid. When it is not 0.0, Vmppt upper/lower limit is automatically adjusted at an interval specified by P15.29 . The center after the adjustment is the actual PV voltage, and the upper/lower limit adjustment range is P15.30 . That is: Maximum/Minimum reference Max./Min. reference voltage = (Actual PV voltage ± P15.30) This will be automatically updated to P15.26 and P15.27 .	1.0s	○
P15.30	Auto adjustment range of Vmppt upper/lower limit	5.0–100.0V Range in which Vmppt upper/lower limit can be automatically adjusted.	30.0V	○
P15.31	Vmppt max. value	P15.27 –6553.5V During the max. power tracking, the upper limit of the solar panel reference voltage will not exceed the value of P15.31 . The factory value depends on the model. By default, the value for the -4 models is 750V and the value for other models is 400V.	400.0V	○
P15.32	PV input and power frequency input selection	0: Automatic switching mode 1: Power frequency input mode 2: PV input mode If P15.32 is set to 0, the system switches between PV input and power frequency input according to the detected PV voltage and switching threshold. If P15.32 is set to 1, the system forcibly switches to power frequency input; If P15.32 is set to 2, the system forcibly switches to PV input.	2	◎

Function code	Name	Description	Default	Modify								
		Note: P15.32 is invalid when terminal input function 42 is valid.										
P15.33	Threshold for switching to power frequency input	0.0V– P15.34 If PV voltage is lower than the threshold or the light is weak, it can switch to power frequency input through the relay output. If the value is 0, it is invalid. For inverters without boost modules, the switching voltage is determined by the external voltage detection circuit. For inverters with boost modules, the switching voltage is 70V.	70.0V	○								
P15.34	Threshold for switching to PV input	P15.33 –400.0V If PV voltage is greater than the threshold, the system can switch to PV input through relay output with the weak-light wake-up delay P15.24 . To avoid frequent switching, P15.34 shall be greater than P15.33 . When P15.34 is set to 0.0, it is invalid. The default value depends on model.	100.0V	○								
P15.35	Rated pump flow	The pump flow is Q_N when the pump runs at the rated frequency and lift. Unit: cubic meter/hour.	0.0	○								
P15.36	Rated pump lift	The pump lift is H_N when the pump runs at the rated frequency and flow. Unit: meter	0.0	○								
P15.37	Voltage setting at PV undervoltage point	When the PV voltage is less than the value of this parameter, the system reports the PV undervoltage fault. The factory value depends on the model. <table border="1" data-bbox="363 1126 775 1326"> <thead> <tr> <th>Model</th> <th>PV undervoltage point</th> </tr> </thead> <tbody> <tr> <td>-SS2</td> <td>140V</td> </tr> <tr> <td>-S2</td> <td>140V</td> </tr> <tr> <td>-2</td> <td>140V</td> </tr> </tbody> </table>	Model	PV undervoltage point	-SS2	140V	-S2	140V	-2	140V	70.0	○
Model	PV undervoltage point											
-SS2	140V											
-S2	140V											
-2	140V											

Function code	Name	Description	Default	Modify				
		<table border="1"> <tr> <td>-4</td> <td>240V</td> </tr> <tr> <td>Any model with the boost module</td> <td>70V</td> </tr> </table>	-4	240V	Any model with the boost module	70V		
-4	240V							
Any model with the boost module	70V							
		Setting range: 0.0–400.0						
P15.39	Product model	<p>This function code is provided for users to change models. For example, if the user wants to use model -4 (default after factory delivery) as model -2, P15.39 shall be set to 2.</p> <p>0: Model -SS2, 220V 1PH input and 1PH output 1: Model -S2, 220V 1PH input and 3PH output 2: Model -2, 220V 3PH input and 3PH output 3: Model -4, 380V 3PH input and 3PH output</p> <p>Setting range: 0–3</p>	0	⊙				

P17 group Status viewing

Function code	Name	Description	Default	Modify
P17.38	Current of the main winding	It is the current of the main winding when applying capacitance-removing to control the single phase motor. 0.00–100.00A	0.0A	●
P17.39	Current of the secondary winding	It is the current of the secondary winding when applying capacitance-removing to control the single phase motor. 0.00–100.00A	0.0A	●

P18 group Status viewing functions special for solar inverters

Function code	Name	Description	Default	Modify
P18.00	PV reference voltage	MPPT is implemented at the inverter side. This value is determined at the inverter side.		●
P18.01	Actual PV voltage	It is transferred from the boost module or equal to the bus voltage.		●
P18.02	MPPT min. reference voltage display	The value displays the mini. voltage reference during max. power tracking. It equals the solar cell panel open-circuit voltage multiplied P15.26 .		●
P18.04	Present inductive current	It is transferred from the boost module. This function code is valid only in AC mode and invalid in PV mode.		●
P18.07	PV input power	Reserved. Unit: kW		●
P18.08	Previous PV input power	Reserved. Unit: kW		●
P18.09	Previous PV voltage	Reserved. Unit: kW		●
P18.10	Device configuration display	0x00–0x11 LED ones: 0: PV power supply 1: AC grid power supply LED tens: 0: Detect that the system is configured with the boost module. 1: Detect that the system is not configured with the boost module.		●
P18.11	Actual pump flow	$Q = Q_N * f / f_N$ Unit: cubic meter/hour	0.0	●
P18.12	Actual pump lift	$H = 0.9H_N * (f / f_N)^2$ Unit: meter	0.0	●
P18.13	High-order bits in total pump flow	Used to display the 16 high-order bits of the total pump flow. Unit: cubic meter	0	●
P18.14	Low-order bits in total pump flow	Used to display the 16 low-order bits of the total pump flow. Unit: cubic meter. Total pump flow = P18.13 *65535 + P18.14	0.0	●

Function code	Name	Description	Default	Modify
P18.15	Reset total pump flow	When it is set to 1, the total pump flow can be reset. P18.13 and P18.14 are cleared and then accumulated again. After the resetting succeeds, P18.15 is automatically changed to 0.	0	<input checked="" type="radio"/>

P19 group Functions for voltage boost (inverter module communicates with boost module through RS485 communication)

Function code	Name	Description	Default	Modify
P19.00	Boost voltage loop KP	0.000–65.535	0.500	<input type="radio"/>
P19.01	Boost voltage loop KI	0.000–65.535	0.080	<input type="radio"/>
P19.02	Boost current loop KP	0.000–65.535	0.010	<input type="radio"/>
P19.03	Boost current loop KI	0.000–65.535	0.010	<input type="radio"/>
P19.04	Output current upper limit of boost voltage loop PI	Output upper limit of mppt voltage loop PI, upper limit of the boost current loop reference current. P19.05–15.0A	12.0A	<input type="radio"/>
P19.06	Bus reference voltage	This function code is used to set the reference voltage of bus voltage at PV input when the system is configured with the boost module. By default, the factory value for 220V models is 350V and the factory value for 380V models is 570V. Setting range: 300.0V–600.0V	350.0V	<input checked="" type="radio"/>
P19.07	Boost voltage loop KP1	If the difference between the bus reference voltage and actual bus voltage is greater than 20V, the boost voltage loop uses PI parameters of this group. Otherwise, the boost voltage loop uses PI parameters of the first group. Setting range: 0.000–65.535	0.500	<input type="radio"/>

Function code	Name	Description	Default	Modify
P19.08	Boost voltage loop KI1	If the difference between the bus reference voltage and actual bus voltage is greater than 20V, the boost voltage loop uses the PI parameters of this group. Otherwise, the boost voltage loop uses the PI parameters of the first group. Setting range: 0.000–65.535	0.080	○
P19.10	Boost software version	Once being powered, the boost module sends its version information to the inverter module.	0.00	●

Note:

- The duration from when the inverter starts to when it runs at the PI output frequency lower limit is determined by the ACC time.
- Delay time counting follows the rules if multiple fault conditions are met simultaneously: For example, if all fault conditions of weak light, full water, and underload are met simultaneously, the delay time for each fault is counted independently. When the delay time of a fault is reached, the fault is reported. The delay time counting for the other two faults is kept. If the reported faults is resolved by the conditions of the other two faults persist, the delay time counting of the other two faults continues. If a fault condition is not met during counting, the delay time of this fault is cleared.

7 Fault diagnosis and solution

Do as follows after the inverter encounters a fault:

1. Check to ensure there is nothing wrong with the keypad. If not, please contact with the local INVT office.
2. If there is nothing wrong, please check P07 and ensure the corresponding recorded fault parameters to confirm the real state when the current fault occurs by all parameters.
3. See the following table for detailed solution and check the corresponding abnormal state.
4. Eliminate the fault and ask for relative help.
5. Check to eliminate the fault and carry out fault reset to run the inverter.

Note: The numbers enclosed in square brackets such as [1], [2] and [3] in the Fault type column in the following table indicate the inverter fault type codes read through communication.

Fault code	Fault type	Possible cause	Solution
OUt1	[1] Inverter unit U-phase protection	<ul style="list-style-type: none"> ● Acceleration is too fast. ● IGBT module is damaged. 	<ul style="list-style-type: none"> ● Increase the ACC time.
OUt2	[2] Inverter unit V-phase protection	<ul style="list-style-type: none"> ● Misacts are caused by interference. 	<ul style="list-style-type: none"> ● Replace the power unit. ● Check drive wires.
OUt3	[3] Inverter unit W-phase protection	<ul style="list-style-type: none"> ● Drive wires are poorly connected. ● To-ground short circuit occurs. 	<ul style="list-style-type: none"> ● Check whether there is strong interference surrounding the peripheral device.
OC1	[4] Overcurrent during acceleration	<ul style="list-style-type: none"> ● Acceleration or deceleration is too fast. 	<ul style="list-style-type: none"> ● Increase the ACC time. ● Check the input power.
OC2	[5] Overcurrent during deceleration	<ul style="list-style-type: none"> ● The voltage of the grid is too low. 	<ul style="list-style-type: none"> ● Select the inverter with larger power.
OC3	[6] Overcurrent during constant speed running	<ul style="list-style-type: none"> ● The power of the inverter is too low. ● The load transients or is abnormal. ● There is to-ground short circuit or output phase loss. ● There is strong external interference. ● The overvoltage stall protection is disabled. 	<ul style="list-style-type: none"> ● Check whether there is short circuit (to-ground or inter-wire) in the load or the rotation is not smooth. ● Check the output wiring. ● Check whether there is strong interference. ● Check the setting of related function codes. ● The output cable is too long.

Fault code	Fault type	Possible cause	Solution
			For a cable longer than 100m, it is required to configure the corresponding output reactor and debug certain parameters.
OV1	[7] Overvoltage during acceleration	<ul style="list-style-type: none"> ● The input voltage is abnormal. ● There is large energy feedback. ● No braking components. ● Dynamic brake is disabled. 	<ul style="list-style-type: none"> ● Check the input power. ● Check whether the loaded DEC time is too short or the inverter starts when the motor is rotating. ● Install the braking components. ● Check the setting of related function codes.
OV2	[8] Overvoltage during deceleration		
OV3	[9] Overvoltage during constant speed running		
UV	[10] Bus undervoltage	<ul style="list-style-type: none"> ● The voltage of the grid is too low. ● Overvoltage stall protection is disabled. 	<ul style="list-style-type: none"> ● Check the grid input power. ● Check the setting of related function codes.
OL1	[11] Motor overload	<ul style="list-style-type: none"> ● The grid voltage is too low. ● The rated current of the motor is set incorrectly. ● Motor stall or load jumps violently. 	<ul style="list-style-type: none"> ● Check the grid voltage. ● Reset the rated current of the motor. ● Check the load and adjust torque boost.
OL2	[12] Inverter overload	<ul style="list-style-type: none"> ● Acceleration is too fast. ● The rotating motor is reset. ● The grid voltage is too low. ● The load is too heavy. ● The motor power is too small. 	<ul style="list-style-type: none"> ● Increase the ACC time. ● Avoid the restarting after stop. ● Check the grid voltage. ● Select an inverter with larger power. ● Select a proper motor.
SPI	[13] Phase loss on the input side	● Phase loss or violent fluctuation occurred on input R, S, T.	<ul style="list-style-type: none"> ● Check the input power. ● Check the installation wiring.
SPO	[14] Phase loss on output side	● Phase loss output occurs to U, V, W (or the three phases of the load are seriously asymmetrical)	<ul style="list-style-type: none"> ● Check the output wiring. ● Check the motor and cable.
OH1	[15] Rectifier module overheating	● Air duct jam or fan damage occurs.	● Dredge the vent duct or replace the fan.

Fault code	Fault type	Possible cause	Solution
OH2	[16] Inverter module overheat	<ul style="list-style-type: none"> ● Ambient temperature is too high. ● The time of overload running is too long. 	<ul style="list-style-type: none"> ● Lower the ambient temperature.
EF	[17] External fault	<ul style="list-style-type: none"> ● SI external fault input terminals action. 	<ul style="list-style-type: none"> ● Check the external device input.
CE	[18] RS485 communication fault	<ul style="list-style-type: none"> ● The baud rate setting is incorrect. ● A fault occurs to the communication wiring. ● The communication address is incorrect. ● Communication suffers from strong interference. 	<ul style="list-style-type: none"> ● Set a proper baud rate. ● Check the communication interface wiring. ● Set a proper communication address. ● Replace or change the wiring to enhance the anti-interference capability.
ItE	[19] Current detection fault	<ul style="list-style-type: none"> ● The control board connector is in poor contact. ● Hall device is damaged. ● An exception occurs on the magnifying circuit. 	<ul style="list-style-type: none"> ● Check the connector and re-plug. ● Replace the Hall device. ● Change the main control board.
tE	[20] Motor autotuning fault	<ul style="list-style-type: none"> ● The motor capacity does not match the inverter capacity. ● Motor parameters are not set correctly. ● The difference between the parameters obtained from autotuning and the standard parameters is great. ● Autotuning timed out. 	<ul style="list-style-type: none"> ● Change the inverter mode. ● Set the motor type and nameplate parameters correctly. ● Empty the motor load. ● Check the motor wiring and parameter settings. ● Check whether the upper limit frequency is higher than 2/3 of the rated frequency.
EEP	[21] EEPROM operation fault	<ul style="list-style-type: none"> ● Error in reading or writing control parameters. ● EEPROM is damaged. 	<ul style="list-style-type: none"> ● Press STOP/RST for reset. ● Change the main control board.
PIDE	[22] PID feedback disconnection	<ul style="list-style-type: none"> ● PID feedback is disconnected. ● The PID feedback source disappears. 	<ul style="list-style-type: none"> ● Check the PID feedback signal wires. ● Check the PID feedback source.
END	[24] Running time	<ul style="list-style-type: none"> ● The actual running time of 	<ul style="list-style-type: none"> ● Ask the supplier to adjust the

Fault code	Fault type	Possible cause	Solution
	reached	the inverter is longer than the internal set running time.	preset running time.
OL3	[25] Electronic overload	<ul style="list-style-type: none"> ● The inverter reports overload pre-alarm according to the setting. 	<ul style="list-style-type: none"> ● Check the load and overload pre-alarm threshold.
ETH1	[32] To-ground short-circuit fault 1	<ul style="list-style-type: none"> ● Inverter output is short connected to the ground. 	<ul style="list-style-type: none"> ● Check whether the motor wiring is proper.
ETH2	[33] To-ground short-circuit fault 2	<ul style="list-style-type: none"> ● There is a fault in the current detection circuit. 	<ul style="list-style-type: none"> ● Replace the Hall device. ● Change the main control board.
dEu	[34] Speed deviation fault	<ul style="list-style-type: none"> ● The load is too heavy or stalled. 	<ul style="list-style-type: none"> ● Check the load and increase the detection time if the load is normal. ● Check whether control parameters are set correctly.
STo	[35] Mal-adjustment fault	<ul style="list-style-type: none"> ● SM control parameters are set incorrectly. ● Autotuned parameters are not accurate. ● The inverter is not connected to the motor. 	<ul style="list-style-type: none"> ● Check the load and ensure the load is normal. ● Check whether control parameters are set correctly. ● Increase the maladjustment detection time.
LL	[36] Electronic underload	<ul style="list-style-type: none"> ● The inverter reports underload pre-alarm according to the setting. 	<ul style="list-style-type: none"> ● Check the load and underload pre-alarm threshold.
tSF	[37] Hydraulic probe damage	<ul style="list-style-type: none"> ● Hydraulic probe damage. 	<ul style="list-style-type: none"> ● Replace the hydraulic probe.
PINV	[38] PV reverse connection fault	<ul style="list-style-type: none"> ● PV wiring is incorrect. 	<ul style="list-style-type: none"> ● Change the wiring direction of positive and negative terminals, and perform the wiring again.
PVOC	[39] PV overcurrent	<ul style="list-style-type: none"> ● ACC or DEC is too fast. ● The power of the inverter is too low. ● The load transients or is abnormal. ● There is to-ground short circuit. 	<ul style="list-style-type: none"> ● Increase the ACC/DCC time. ● Select the inverter with larger power. ● Check if the load is short circuited (to-ground short circuit or line-to-line short circuit) or the rotation is not smooth.
PVOV	[40] PV overvoltage	<ul style="list-style-type: none"> ● The solar cell panel input 	<ul style="list-style-type: none"> ● Reduce the number of solar

Fault code	Fault type	Possible cause	Solution
		voltage is too high. ● Model -4 is set as another model.	cell panels in series connection. ● Check and reset the model.
PVLV	[41] PV undervoltage	● The power of the solar cell panels in series connection is too low or it is cloudy and rainy weather. ● The starting current of the motor is too high.	● Increase the number of solar cell panels or perform the test in the normal sunlight. ● Replace the motor.
E-422	[42] Fault on 422 communication with the boost module	● Communication cables are in poor contact.	● Check four communication cables of 422 communication, ensuring that they are connected reliably.
OV	[43] Bus overvoltage detected on the boost side	● The sunlight changes sharply.	● Adjust the boost PI parameters, and enlarge the values of P19.07 and P19.08.
A-LS	Weak-light pre-alarm	● The sunlight is weak or the solar panel configuration is insufficient.	● The device will automatically run when the light is sufficient. ● Check whether the solar panel configuration is sufficient.
A-LL	Underload pre-alarm	● The pumping pool has no water.	● Check the pumping pool.
A-tF	Full-water pre-alarm	● The pumping pool is full.	● If you have configured the full-water pre-alarm function, the device automatically stops when the pre-alarm elapsed a period of time. Otherwise, check whether terminals are wired correctly.
A-tL	Empty-water pre-alarm	● The pumping pool has no water.	● If you have configured the empty-water pre-alarm function, the device automatically stops when the pre-alarm elapsed a period of time. Otherwise, check whether terminals are wired correctly.

8 Communication protocol

8.1 Brief instruction to Modbus protocol

Modbus protocol is a software protocol and common language which is applied in the electrical controller. With this protocol, the controller can communicate with other devices via network (the channel of signal transmission or the physical layer, such as RS485). And with this industrial standard, the controlling devices of different manufacturers can be connected to an industrial network for the convenient of being monitored.

There are two transmission modes for Modbus protocol: ASCII mode and RTU (Remote Terminal Units) mode. On one Modbus network, all devices should select same transmission mode and their basic parameters, such as baud rate, digital bit, check bit, and stopping bit should have no difference.

Modbus network is a controlling network with single-master and multiple slaves, which means that there is only one device performs as the master and the others are the slaves on one Modbus network. The master means the device which has active talking right to send message to Modbus network for the controlling and inquiring to other devices. The slave means the passive device which sends data message to the Modbus network only after receiving the controlling or inquiring message (command) from the master (response). After the master sends message, there is a period of time left for the controlled or inquired slaves to response, which ensure there is only one slave sends message to the master at a time for the avoidance of singles impact.

Generally, the user can set PC, PLC, IPC and HMI as the masters to realize central control. Setting certain device as the master is a promise other than setting by a bottom or a switch or the device has a special message format. For example, when the upper monitor is running, if the operator clicks sending command bottom, the upper monitor can send command message actively even it cannot receive the message from other devices. In this case, the upper monitor is the master. And if the designer makes the inverter send the data only after receiving the command, then the inverter is the slave.

The master can communicate with any single slave or with all slaves. For the single-visiting command, the slave should feedback a response message; for the broadcasting message from the master, the slave does not need to feedback the response message.

8.2 Application of the inverter

The inverter uses the Modbus RTU mode and the physical layer is 2-wire RS485.

8.2.1 2-wire RS485

2-wire RS485 interfaces works in half-duplex mode and send data signals in the differential transmission way, which is also referred to as balanced transmission. An RS485 interface uses a twisted pair, in which one wire is defined as A (+), and the other B (-). Generally, if the

positive electrical level between the transmission drives A and B ranges from +2 V to +6 V, the logic is "1"; and if it ranges from -2 V to -6 V, the logic is "0".

On the inverter terminal block, the 485+ terminal corresponds to A, and 485- corresponds to B.

The communication baud rate (P14.01) indicates the number of bits sent in a second, and the unit is bit/s (bps). A higher baud rate indicates faster transmission and poorer anti-interference capability. When a twisted pair of 0.56mm (24 AWG) is used, the maximum transmission distance varies according to the baud rate, as described in the following table.

Baud rate	Max. transmission distance	Baud rate	Max. transmission distance	Baud rate	Max. transmission distance	Baud rate	Max. transmission distance
2400 bps	1800m	4800 bps	1200m	9600 bps	800m	19200 bps	600m

When RS485 interfaces are used for long-distance communication, it is recommended that you use shielded cables, and use the shielding layer as the ground wires.

When there are fewer devices and the transmission distance is short, the whole network works well without terminal load resistors. The performance, however, degrades as the distance increases. Therefore, it is recommended that you use a 120Ω terminal resistor when the transmission distance is long.

8.2.1.1 When one inverter is used

Figure 8-1 is the Modbus wiring diagram for the network with one inverter and PC. Generally, PCs do not provide RS485 interfaces, and therefore you need to convert an RS232 or USB interface of a PC to an RS485 interface through a converter. Then, connect end A of the RS485 interface to the 485+ port on the terminal block of the inverter, and connect end B to the 485- port. It is recommended that you use shielded twisted pairs. When an RS232-RS485 converter is used, the cable used to connect the RS232 interface of the PC and the converter cannot be longer than 15 m. Use a short cable when possible. It is recommended that you insert the converter directly into the PC. Similarly, when a USB-RS485 converter is used, use a short cable when possible.

When the wiring is completed, select the correct port (for example, COM1 to connect to the RS232-RS485 converter) for the upper computer of the PC, and keep the settings of basic parameters such as communication baud rate and data check bit consistent with those of the inverter.

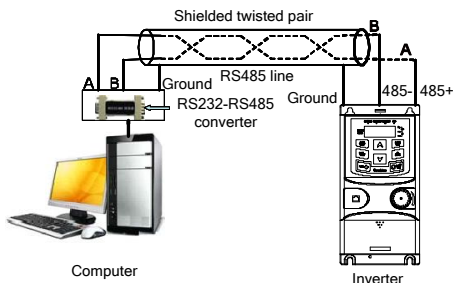

Figure 8-1 RS485 wiring diagram for the network with one inverter

8.2.1.2 When multiple inverters are used

In the network with multiple inverters, chrysanthemum connection and star connection are commonly used. According to the requirements of the RS485 industrial bus standards, all the devices need to be connected in chrysanthemum mode with one 120 Ω terminal resistor on each end, as shown in Figure 8-2.

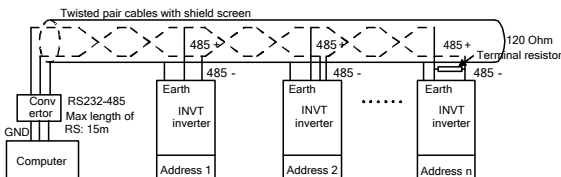

Figure 8-2 Practical application diagram of chrysanthemum connection

Figure 8-3 shows the start connection diagram. When this connection mode is adopted, the two devices that are farthest away from each other on the line must be connected with a terminal resistor (in this figure, the two devices are devices 1# and 15#).

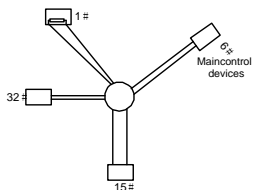

Figure 8-3 Star connection

Use shielded cables, if possible, in multi-inverter connection. The baud rates, data bit check settings, and other basic parameters of all the devices on the RS485 line must be set consistently, and addresses cannot be repeated.

8.2.2 RTU mode

8.2.2.1 RTU communication frame structure

When a controller is set to use the RTU communication mode on a Modbus network, every byte (8 bits) in the message includes 2 hexadecimal characters (each includes 4 bits). Compared with the ASCII mode, the RTU mode can transmit more data with the same baud rate.

Code system

- 1 start bit
- 7 or 8 data bits; the minimum valid bit is transmitted first. Each frame domain of 8 bits includes 2 hexadecimal characters (0–9, A–F).
- 1 odd/even check bit; this bit is not provided if no check is needed.
- 1 stop bit (with check performed), or 2 bits (without check)

Error detection domain

- Cyclic redundancy check (CRC)

The following table describes the data format.

11-bit character frame (Bits 1 to 8 are data bits)

Start bit	BIT1	BIT2	BIT3	BIT4	BIT5	BIT6	BIT7	BIT8	Check bit	Stop bit
-----------	------	------	------	------	------	------	------	------	-----------	----------

10-bit character frame (Bits 1 to 7 are data bits)

Start bit	BIT1	BIT2	BIT3	BIT4	BIT5	BIT6	BIT7	Check bit	Stop bit
-----------	------	------	------	------	------	------	------	-----------	----------

In a character frame, only the data bits carry information. The start bit, check bit, and stop bit are used to facilitate the transmission of the data bits to the destination device. In practical applications, you must set the data bits, parity check bits, and stop bits consistently.

In RTU mode, the transmission of a new frame always starts from an idle time (the transmission time of 3.5 bytes). On a network where the transmission rate is calculated based on the baud rate, the transmission time of 3.5 bytes can be easily obtained. After the idle time ends, the data domains are transmitted in the following sequence: slave address, operation command code, data, and CRC check character. Each byte transmitted in each domain includes 2 hexadecimal characters (0–9, A–F). The network devices always monitor the communication bus. After receiving the first domain (address information), each network device identifies the byte. After the last byte is transmitted, a similar transmission interval (the transmission time of 3.5 bytes) is used to indicate that the transmission of the frame ends. Then, the transmission of a new frame starts.

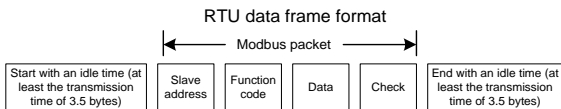

The information of a frame must be transmitted in a continuous data flow. If there is an interval greater than the transmission time of 1.5 bytes before the transmission of the entire frame is complete, the receiving device deletes the incomplete information, and mistakes the subsequent byte for the address domain of a new frame. Similarly, if the transmission interval between two frames is shorter than the transmission time of 3.5 bytes, the receiving device mistakes it for the data of the last frame. The CRC check value is incorrect due to the disorder of the frames, and thus a communication fault occurs.

The following table describes the standard structure of an RTU frame.

START (frame header)	T1-T2-T3-T4 (time gap with a min. length of 3.5 bytes)
ADDR (slave address domain)	Communication address: 0–247 (in decimal system) (0 indicates the broadcast address)
CMD (function domain)	03H: read slave parameters 06H: write slave parameters
Data domain DATA (N-1) ... DATA (0)	Data of 2*N bytes, main content of the communication as well as the core of data exchanging
LSB of CRC CHK	Detection value: CRC (16 bits)
MSB of CRC CHK	
END (frame tail)	T1-T2-T3-T4 (time gap with a min. length of 3.5 bytes)

8.2.2.2 RTU communication frame error check modes

During the transmission of data, errors may occur due to various factors (such as electromagnetic interference). For example, if the sending message is a logic "1", A-B

potential difference on RS485 should be 6V, but in reality, it may be -6V because of electromagnetic interference, and then the other devices take the sent message as logic "0". Without error check, the data receiving device cannot identify data errors and may make a wrong response. The wrong response may cause severe problems. Therefore, the data must be checked.

The check is implemented as follows: The transmitter calculates the to-be-transmitted data based on a specific algorithm to obtain a result, adds the result to the rear of the message, and transmits them together. After receiving the message, the receiver calculates the data based on the same algorithm to obtain a result, and compares the result with that transmitted by the transmitter. If the results are the same, the message is correct. Otherwise, the message is considered wrong.

The error check of a frame includes two parts, namely, bit check on individual bytes (that is, odd/even check using the check bit in the character frame), and whole data check (CRC check).

Bit check on individual bytes (odd/even check)

You can select the bit check mode as required, or you can choose not to perform the check, which will affect the check bit setting of each byte.

Definition of even check: Before the data is transmitted, an even check bit is added to indicate whether the number of "1" in the to-be-transmitted data is odd or even. If it is even, the check bit is set to "0"; and if it is odd, the check bit is set to "1".

Definition of odd check: Before the data is transmitted, an odd check bit is added to indicate whether the number of "1" in the to-be-transmitted data is odd or even. If it is odd, the check bit is set to "0"; and if it is even, the check bit is set to "1".

For example, the data bits to be transmitted are "11001110", including five "1". If the even check is applied, the even check bit is set to "1"; and if the odd check is applied, the odd check bit is set to "0". During the transmission of the data, the odd/even check bit is calculated and placed in the check bit of the frame. The receiving device performs the odd/even check after receiving the data. If it finds that the odd/even parity of the data is inconsistent with the preset information, it determines that a communication error occurs.

Cyclical Redundancy Check (CRC) method

A frame in the RTU format includes an error detection domain based on the CRC calculation. The CRC domain checks all the content of the frame. The CRC domain consists of two bytes, including 16 binary bits. It is calculated by the transmitter and added to the frame. The receiver calculates the CRC of the received frame, and compares the result with the value in the received CRC domain. If the two CRC values are not equal to each other, errors occur in the transmission.

During CRC, 0xFFFF is stored first, and then a process is invoked to process a minimum of 6

contiguous bytes in the frame based on the content in the current register. CRC is valid only for the 8-bit data in each character. It is invalid for the start, stop, and check bits.

During the generation of the CRC values, the "exclusive or" (XOR) operation is performed on the each 8-bit character and the content in the register. The result is placed in the bits from the low-order bit to the high-order bit, and 0 is placed in the high-order bit. Then, the low-order bit is detected. If the low-order bit is 1, the XOR operation is performed on the current value in the register and the preset value. If low-order bit is 0, no operation is performed. This process is repeated 8 times. After the last bit (8th bit) is detected and processed, the XOR operation is performed on the next 8-bit byte and the current content in the register. The final values in the register are the CRC values obtained after operations are performed on all the bytes in the frame.

The calculation adopts the international standard CRC check rule. You can refer to the related standard CRC algorithm to compile the CRC calculation program as required.

The following example is a simple CRC calculation function for your reference (using the C programming language):

```
unsigned int crc_cal_value(unsigned char *data_value,unsigned char
data_length)
{
int i;
unsigned int crc_value=0xffff;
while(data_length--)
{
  crc_value^=*data_value++;
  for(i=0;i<8;i++)
  {
if(crc_value&0x0001)crc_value=(crc_value>>1)^0xa001;
  else crc_value=crc_value>>1;
  }
}
return(crc_value);
}
```

In the ladder logic, CKSM uses the table look-up method to calculate the CRC value according to the content in the frame. The program of this method is simple, and the calculation is fast, but the ROM space occupied is large. Use this program with caution in scenarios where there are space occupation requirements on programs.

8.2.3 ASCII mode

Name	Definition																		
Coding system	Communication protocol belongs to hexadecimal system. The meaning of message character in ASCII: "0"... "9", "A"... "F", each hex is represented by the ASCII message corresponds to the character.																		
	<table border="1"> <thead> <tr> <th>Character</th> <th>"0"</th> <th>"1"</th> <th>"2"</th> <th>"3"</th> <th>"4"</th> <th>"5"</th> <th>"6"</th> <th>"7"</th> </tr> </thead> <tbody> <tr> <td>ASCII CODE</td> <td>0x30</td> <td>0x31</td> <td>0x32</td> <td>0x33</td> <td>0x34</td> <td>0x35</td> <td>0x36</td> <td>0x37</td> </tr> </tbody> </table>	Character	"0"	"1"	"2"	"3"	"4"	"5"	"6"	"7"	ASCII CODE	0x30	0x31	0x32	0x33	0x34	0x35	0x36	0x37
	Character	"0"	"1"	"2"	"3"	"4"	"5"	"6"	"7"										
	ASCII CODE	0x30	0x31	0x32	0x33	0x34	0x35	0x36	0x37										
<table border="1"> <thead> <tr> <th>Character</th> <th>"8"</th> <th>"9"</th> <th>"A"</th> <th>"B"</th> <th>"C"</th> <th>"D"</th> <th>"E"</th> <th>"F"</th> </tr> </thead> <tbody> <tr> <td>ASCII CODE</td> <td>0x38</td> <td>0x39</td> <td>0x41</td> <td>0x42</td> <td>0x43</td> <td>0x44</td> <td>0x45</td> <td>0x46</td> </tr> </tbody> </table>	Character	"8"	"9"	"A"	"B"	"C"	"D"	"E"	"F"	ASCII CODE	0x38	0x39	0x41	0x42	0x43	0x44	0x45	0x46	
Character	"8"	"9"	"A"	"B"	"C"	"D"	"E"	"F"											
ASCII CODE	0x38	0x39	0x41	0x42	0x43	0x44	0x45	0x46											
Data format	Starting bit, 7/8 data bit, check bit and stop bit. The data formats are listed as follows. 11-bit character frame:																		
	<table border="1"> <tr> <td>Starting bit</td> <td>BIT 1</td> <td>BIT2</td> <td>BIT3</td> <td>BIT4</td> <td>BIT5</td> <td>BIT6</td> <td>BIT7</td> <td>BIT 8</td> <td>Check bit</td> <td>Stop bit</td> </tr> </table>	Starting bit	BIT 1	BIT2	BIT3	BIT4	BIT5	BIT6	BIT7	BIT 8	Check bit	Stop bit							
Starting bit	BIT 1	BIT2	BIT3	BIT4	BIT5	BIT6	BIT7	BIT 8	Check bit	Stop bit									
	10-bit character frame:																		
	<table border="1"> <tr> <td>Starting bit</td> <td>BIT1</td> <td>BIT2</td> <td>BIT3</td> <td>BIT4</td> <td>BIT5</td> <td>BIT6</td> <td>BIT7</td> <td>Check bit</td> <td>Stop bit</td> </tr> </table>	Starting bit	BIT1	BIT2	BIT3	BIT4	BIT5	BIT6	BIT7	Check bit	Stop bit								
Starting bit	BIT1	BIT2	BIT3	BIT4	BIT5	BIT6	BIT7	Check bit	Stop bit										

In ASCII mode, the frame header is ":" ("0x3A"), frame end is "CRLF" ("0x0D" "0x0A") by default. In ASCII mode, all the data bytes, except for the frame header and frame end, are transmitted in ASCII code mode, in which four MSB groups will be sent out first and then, four LSB groups will be sent out. In ASCII mode, the data length is 8 bit. As for "A"-"F", its capital letters is adopted for ASCII code. The data now adopts LRC checkout which covers slave address to data information. The checksum equals to the complement of the character sum of all the participated checkout data.

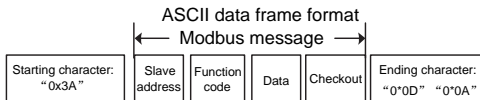

Standard structure of ASCII frame:

START	":" (0x3A)
Address Hi	Communication address:
Address Lo	
Function Hi	Function code:
Function Lo	
DATA (N-1)	Data content:

...	nx8-bit data content is formed by combination of 2n (n≤16) ASCII codes
DATA (0)	
LRC CHK Hi	LRC check code: 8-bit check code is formed by the combination of two ASCII codes.
LRC CHK Lo	
END Hi	End character: END Hi=CR (0x0D), END Lo=LF (0x0A)
END Lo	

8.2.3.1 ASCII mode check (LRC Check)

Check code (LRC Check) is the value combined of address and data content result. For instance, the check code of above 2.2.2 communication message is: $0x02+0x06+0x00+0x08+0x13+0x88=0xAB$, then take the compliment of 2= $0x55$.

The following example is a simple LRC calculation function for your reference (using the C programming language):

```
Static unsigned char
LRC (auchMsg, usDataLen)
unsigned char *auchMsg;
unsigned short usDataLen;
{
unsigned char uchLRC=0;
while (usDataLen--)
uchLRC+=*auchMsg++;
return ((unsigned char) (~((char)uchLRC)));
}
```

8.3 Command code and communication data

8.3.1 RTU mode

8.3.1.1 Command code 03H (corresponding to binary 0000 0011), read N words (Word) (N≤16)

Command code 03H means that if the master read data from the inverter, the reading number depends on the "data number" in the command code. The max continuous reading number is 16 and the parameter address should be continuous. The byte length of every data is 2 (one word). The following command format is illustrated by hex (a number with "H" means hex) and one hex occupies one byte.

The command code is used to read the working state of the inverter.

For example, read continuous 2 data content from 0004H from the inverter with the address of

01H (read the content of data address of 0004H and 0005H), the frame structure is as follows.

RTU master command (sent from the master to the inverter)		RTU slave response (sent from the inverter to the master)	
START	T1-T2-T3-T4	START	T1-T2-T3-T4
ADDR	01H	ADDR	01H
CMD	03H	CMD	03H
		Byte number	04H
MSB of the start address	00H	MSB of data in 0004H	13H
LSB of the start address	04H	LSB of data in 0004H	88H
MSB of data number	00H	MSB of data in 0005H	00H
LSB of data number	02H	LSB of data in 0005H	00H
LSB of CRC	85H	LSB of CRC CHK	7EH
MSB of CRC	CAH	LSB of CRC CHK	9DH
END	T1-T2-T3-T4	END	T1-T2-T3-T4

T1-T2-T3-T4 between START and END is to provide at least the time of 3.5 bytes as the leisure time and distinguish two messages for the avoidance of taking two messages as one message.

ADDR = 01H means the command message is sent to the inverter with the address of 01H and ADDR occupies one byte

CMD=03H means the command message is sent to read data from the inverter and CMD occupies one byte

"Start address" means reading data from the address and it occupies 2 bytes with the fact that the MSB is in the front and the LSB is in the behind.

"Data number" means the reading data number with the unit of word. If the "start address" is 0004H and the "data number" is 0002H, the data of 0004H and 0005H will be read.

CRC occupies 2 bytes with the fact that the LSB is in the front and the MSB is in the behind.

The meaning of the response is that:

ADDR = 01H means the command message is transmitted by the inverter whose address is 01H. The ADDR information occupies one byte.

CMD=03H means the message is received from the inverter to the master for the response of reading command The CMD information occupies one byte.

"Byte number" means all byte number from the byte (excluding the byte) to CRC byte (excluding the byte). 04 means there are 4 byte of data from the "byte number" to "LSB of

CRC CHK", which are "MSB of data in 0004H", "LSB of data in 0004H", "MSB of data in 0005H" and "LSB of data in 0005H".

There are 2 bytes stored in one data with the fact that the MSB is in the front and the LSB is in the behind of the message, the data of data address 0004H is 1388H, and the data of data address 0005H is 0000H.

CRC occupies 2 bytes with the fact that the LSB is in the front and the MSB is in the behind.

8.3.1.2 Command code 06H (corresponding to binary 0000 0110), write a word

The command means that the master write data to the inverter and one command can write one data other than multiple dates. The effect is to change the working mode of the inverter.

For example, write 5000 (1388H) to 0004H from the inverter with the address of 02H, the frame structure is as follows.

RTU master command (sent from the master to the inverter)		RTU slave response (sent from the inverter to the master)	
START	T1-T2-T3-T4	START	T1-T2-T3-T4
ADDR	02H	ADDR	02H
CMD	06H	CMD	06H
MSB of data writing address	00H	MSB of data writing address	00H
LSB of data writing address	04H	LSB of data writing address	04H
MSB of to-be-written data	13H	MSB of to-be-written data	13H
LSB of to-be-written data	88H	LSB of to-be-written data	88H
LSB of CRC CHK	C5H	LSB of CRC CHK	C5H
MSB of CRC CHK	6EH	MSB of CRC CHK	6EH
END	T1-T2-T3-T4	END	T1-T2-T3-T4

Note: Sections 8.3.1.1 and 8.3.1.2 mainly describe the command format.

8.3.1.3 Command code 10H, continuous writing

Command code 10H means that if the master writes data to the inverter, the data number depends on the "data number" in the command code. The max continuous reading number is 16.

For example, write 5000 (1388H) to 0004H of the inverter whose slave address is 02H and 50 (0032H) to 0005H, the frame structure is as follows.

The RTU request command is:

START	T1-T2-T3-T4 (time gap with a min. length of 3.5 bytes)
ADDR	02H
CMD	10H
MSB of data writing address	00H
LSB of data writing address	04H
MSB of data quantity	00H
LSB of data quantity	02H
Byte number	04H
MSB of data in 0004H	13H
LSB of data in 0004H	88H
MSB of data in 0005H	00H
LSB of data in 0005H	32H
LSB of CRC	C5H
MSB of CRC	6EH
END	T1-T2-T3-T4 (time gap with a min. length of 3.5 bytes)

The RTU response command is:

START	T1-T2-T3-T4 (time gap with a min. length of 3.5 bytes)
ADDR	02H
CMD	10H
MSB of data writing address	00H
LSB of data writing address	04H
MSB of data quantity	00H
LSB of data quantity	02H
LSB of CRC	C5H
MSB of CRC	6EH
END	T1-T2-T3-T4 (time gap with a min. length of 3.5 bytes)

8.3.2 ASCII mode

8.3.2.1 Command code: 03H (0000 0011), read N words (Word) (max. number for continuous reading is 16 words)

For instance: As for the inverter whose slave address is 01H, the starting address of internal storage is 0004, read two words continuously, the structure of this frame is listed as follows.

ASCII master command (sent from the master to the inverter)		ASCII slave response (sent from the inverter to the master)	
START	":"	START	":"
ADDR	"0"	ADDR	"0"
	"1"		"1"
CMD	"0"	CMD	"0"
	"3"		"3"
MSB of starting address	"0"	Byte number	"0"
	"0"		"4"
LSB of starting address	"0"	MSB of data address 0004H	"1"
	"4"		"3"
MSB of data number	"0"	LSB of data address 0004H	"8"
	"0"		"8"
LSB of data number	"0"	MSB of data address 0005H	"0"
	"2"		"0"
LRC CHK Hi	"F"	LSB of data address 0005H	"0"
LRC CHK Lo	"6"		"0"
END Hi	CR	LRC CHK Hi	"5"
END Lo	LF	LRC CHK Lo	"D"
		END Hi	CR
		END Lo	LF

8.3.2.2 Command code: 06H (0000 0110), write a word (Word)

For instance: Write 5000 (1388H) to the 0004H address of the inverter whose slave address is 02H, then the structure of this frame is listed as follows.

ASCII master command (sent from the master to the inverter)		ASCII slave response (sent from the inverter to the master)	
START	":"	START	":"
ADDR	"0"	ADDR	"0"
	"2"		"2"
CMD	"0"	CMD	"0"
	"6"		"6"
MSB of data writing address	"0"	MSB of data writing address	"0"
	"0"		"0"
LSB of data writing address	"0"	LSB of data writing address	"0"
	"4"		"4"
MSB of to-be-written data	"1"	MSB of to-be-written data	"1"
	"3"		"3"
LSB of to-be-written	"8"	LSB of to-be-written	"8"

ASCII master command (sent from the master to the inverter)		ASCII slave response (sent from the inverter to the master)	
data	"8"	data	"8"
LRC CHK Hi	"5"	LRC CHK Hi	"5"
LRC CHK Lo	"9"	LRC CHK Lo	"9"
END Hi	CR	END Hi	CR
END Lo	LF	END Lo	LF

8.3.2.3 Command code: 10H, continuous writing

Command code 10H means the master write data to the inverter, the number of data being written is determined by the command "data number", the max. number of continuous writing is 16 words.

For instance: Write 5000 (1388H) to 0004H of the inverter whose slave address is 02H, write 50 (0032H) to 0005H of the inverter whose slave address is 02H, then the structure of this frame is listed as follows.

ASCII master command (sent from the master to the inverter)		ASCII slave response (sent from the inverter to the master)	
START	","	START	","
ADDR	"0"	ADDR	"0"
	"2"		"2"
CMD	"1"	CMD	"1"
	"0"		"0"
MSB of starting address	"0"	MSB of starting address	"0"
	"0"		"0"
LSB of starting address	"0"	LSB of starting address	"0"
	"4"		"4"
MSB of data number	"0"	MSB of data number	"0"
	"0"		"0"
LSB of data number	"0"	LSB of data number	"0"
	"2"		"2"
Byte number	"0"	LRC CHK Hi	"E"
	"4"	LRC CHK Lo	"8"
MSB of data to be written to 0004H LSB of data to be written to 0004H	"1"	END Hi	CR
	"3"	END Lo	LF
MSB of data to be written to 0005H	"8"	/	/
	"8"	/	/

ASCII master command (sent from the master to the inverter)		ASCII slave response (sent from the inverter to the master)	
MSB of data to be written to 0004H LSB of data to be written to 0004H	"0"	/	/
	"0"	/	/
MSB of data to be written to 0005H	"3"	/	/
	"2"	/	/
LRC CHK Hi	"1"	/	/
LRC CHK Lo	"7"	/	/
END Hi	CR	/	/
END Lo	LF	/	/

8.4 Data address definition

This section describes the address definition of communication data. The addresses are used for controlling the running, obtaining the status information, and setting function parameters of the inverter.

8.4.1 Function code address format rules

The parameter address occupies 2 bytes with the fact that the MSB is in the front and the LSB is in the behind. The range of MSB and LSB are: MSB—00–ffH; LSB—00–ffH. The MSB is the group number before the radix point of the function code and the LSB is the number after the radix point. But both the MSB and the LSB should be changed into hex. For example P05.05, the group number before the radix point of the function code is 05, then the MSB of the parameter is 05, the number after the radix point 05, then the LSB of the parameter is 05, then the function code address is 0505H and the parameter address of P11.01 is 0B01H.

Function code	Name	Description	Default	Modify
P11.01	Frequency decrease at sudden power loss	0: Disable 1: Enable	0	<input type="radio"/>

Note:

- ✧ P29 group is the factory parameter which cannot be read or changed. Some parameters cannot be changed when the inverter is in the running state and some parameters cannot be changed in any state. The setting range, unit and related instructions should be paid attention to when modifying the function code parameters.
- ✧ Besides, EEPROM is stocked frequently, which may shorten the usage time of EEPROM. For users, some functions are not necessary to be stocked on the communication mode.

The needs can be met on by changing the value in RAM. Changing the MSB of the function code form 0 to 1 can also realize the function. For example, the function code P00.13 is not stocked into EEPROM. Only by changing the value in RAM can set the address to 8007H. This address can only be used in writing RAM other than reading. If it is used to read, it is an invalid address.

8.4.2 Description of other function addresses in Modbus

The master can operate on the parameters of the inverter as well as control the inverter, such as running or stopping and monitoring the working state of the inverter.

Below is the parameter list of other functions.

Function instruction	Address definition	Data meaning instruction	R/W characteristics
Communication control command	2000H	0001H: Forward running	R/W
		0002H: Reverse running	
		0003H: Forward jogging	
		0004H: Reverse jogging	
		0005H: Stop	
		0006H: Coast to stop	
		0007H: Fault reset	
		0008H: Jogging to stop	
Address of the communication setting value	2001H	Communication setting frequency (0–Fmax (unit: 0.01Hz))	R/W
	2002H	PID reference, range (0–1000, 1000 corresponds to100.0%)	R/W
	2003H	PID feedback, range (0–1000, 1000 corresponds to100.0%)	R/W
	2004H	Torque setting value (-3000–3000, 1000 corresponds to the 100.0% of the rated current of the motor)	R/W
	2005H	The upper limit frequency setting during forward rotation (0–Fmax (unit: 0.01Hz))	R/W
	2006H	The upper limit frequency setting during reverse rotation (0–Fmax (unit: 0.01Hz))	R/W
	2007H	The upper limit torque of electromotion torque (0–3000, 1000 corresponds to the 100.0% of the rated current of the motor)	R/W
	2008H	The upper limit torque of braking torque (0–3000, 1000 corresponds to the 100.0% of the rated current of the motor)	R/W

Function instruction	Address definition	Data meaning instruction	R/W characteristics
	2009H	Special control command word Bit0-1: =00: motor 1 =01: motor 2 =10: motor 3 =11: motor 4 Bit2: =1 torque control prohibit =0: torque control prohibit invalid Bit3: =1 power consumption clear =0: no power consumption clear Bit4: =1 pre-exciting =0: pre-exciting prohibition Bit5: =1 DC braking =0: DC braking prohibition	R/W
	200AH	Virtual input terminal command, range: 0x00-0x1FF	R/W
	200BH	Virtual output terminal command, range: 0x00-0x0F	R/W
	200CH	Voltage setting value (special for V/F separation) (0-1000, 1000 corresponds to the 100.0% of the rated voltage of the motor)	R/W
	200DH	AO output setting 1 (-1000-1000, 1000 corresponds to 100.0%)	R/W
	200EH	AO output setting 2 (-1000-1000, 1000 corresponds to 100.0%)	R/W
SW 1 of the inverter	2100H	0001H: Forward running	R
		0002H: Forward running	
		0003H: Stop	
		0004H: Fault	
		0005H: POFF state	
		0006H: Pre-exciting state	
SW 1 of the inverter	2101H	Bit0: =0: bus voltage is not established =1: bus voltage is established Bit1-2: =00: motor 1 =01: motor 2 =10: motor 3 =11: motor 4 Bit3: =0: asynchronous motor =1: synchronous motor	R

Function instruction	Address definition	Data meaning instruction		R/W characteristics
		Bit4: =0: pre-alarm without overload =1: overload pre-alarm Bit5–Bit6: =00: keypad control =01: terminal control =10: communication control		
Fault code of the inverter	2102H	See the fault type instruction		R
Identifying code of the inverter	2103H	GD100-PV-----0x0190		R
Running frequency	3000H	0–Fmax (Unit: 0.01Hz)	Compatible with GD series, CHF100A, and CHV100 communication addresses	R
Set frequency	3001H	0–Fmax (Unit: 0.01Hz)		R
Bus voltage	3002H	0.0–2000.0V (Unit: 0.1V)		R
Output voltage	3003H	0–1200V (Unit: 1V)		R
Output current	3004H	0.0–3000.0A (Unit: 0.1A)		R
Rotating speed	3005H	0–65535 (Unit: 1RPM)		R
Output power	3006H	-300.0–300.0% (Unit: 0.1%)		R
Output torque	3007H	-250.0–250.0% (Unit: 0.1%)		R
PID setting	3008H	-100.0–100.0% (Unit: 0.1%)		R
PID feedback	3009H	-100.0–100.0% (Unit: 0.1%)		R
Input state	300AH	000–1FF		
Output state	300BH	000–1FF		
AI 1	300CH	0.00–10.00V (Unit: 0.01V)		R
AI 2	300DH	0.00–10.00V (Unit: 0.01V)		R
AI 3	300EH	-10.00–10.00V (Unit: 0.01V)		R
AI 4	300FH	Reserved	R	
Read input of high-speed pulse 1	3010H	0.000–50.000kHz (Unit: 0.01Hz)	R	

Function instruction	Address definition	Data meaning instruction		R/W characteristics
Read input of high-speed pulse 2	3011H	Reserved		R
PLC and current step of multi-step speed	3012H	0-15		R
External length	3013H	0-65535		R
External count value	3014H	0-65535		R
Torque setting	3015H	-300.0-300.0% (Unit: 0.1%)		R
Inverter identification code	3016H			R
Fault code	5000H			R

R/W characteristics means the function is with read and write characteristics. For example, "communication control command" is writing characteristics and control the inverter with writing command (06H). R characteristic can only read other than write and W characteristic can only write other than read.

Note: when operating on the inverter with the table above, it is necessary to enable some parameters. For example, the operation of running and stopping, it is necessary to set P00.01 to communication running command channel.

The encoding rules for device codes (corresponding to identifying code 2103H of the inverter

MSB of code	Meaning	LSB of code	Meaning
0x01	Goodrive	90	Goodrive100-PV Series Solar Pump Inverter

Note: The code is consisted of 16 bit which is high 8 bits and low 8 bits. High 8 bits mean the motor type series and low 8 bits mean the derived motor types of the series.

8.4.3 Fieldbus ratio values

The communication data is expressed by hex in actual application and there is no radix point in hex. For example, 50.12Hz cannot be expressed by hex so 50.12 can be magnified by 100 times into 5012, so hex 1394H can be used to express 50.12.

A non-integer can be timed by a multiple to get an integer and the integer can be called fieldbus ratio values.

The fieldbus ratio values are referred to the radix point of the setting range or default value in the function parameter list. If there are figures behind the radix point ($n=1$), then the fieldbus

ratio value m is 10^n . Take the table as the example:

Function code	Name	Description	Default	Modify
P01.21	Power-off restart selection	0: Disable 1: Enable	0	<input type="radio"/>

The value specified in "Setting range" or "Default" contains one decimal, so the fieldbus scale is 10. If the value received by the upper computer is 50, the value of "Wake-up-from-sleep delay" of the inverter is 5.0 ($5.0=50/10$).

To set the "Wake-up-from-sleep delay" to 5.0s through Modbus communication, you need first to multiply 5.0 by 10 according to the scale to obtain an integer 50, that is, 32H in the hexadecimal form, and then transmit the following write command:

01 06 01 14 00 32 49 E7

Inverter Write Parameters Data number CRC check
address command address

After receiving the command, the inverter converts 50 into 5.0 based on the fieldbus scale, and then sets "Wake-up-from-sleep delay" to 5.0s.

For another example, after the upper computer transmits the "Wake-up-from-sleep delay" parameter command, the master receives the following response from the inverter:

01 03 02 00 32 39 91

Inverter Read 2-byte Parameters CRC check
address command data data

The parameter data is 0032H, that is, 50, so 5.0 is obtained based on the fieldbus scale ($50/10=5.0$). In this case, the master identifies that the "Wake-up-from-sleep delay" is 5.0s.

8.4.4 Error message response

Operation errors may occur in communication-based control. For example, some parameters can only be read, but a write command is transmitted. In this case, the inverter returns an error message response. Error message responses are sent from the inverter to the master. The following table describes the codes and definitions of the error message responses.

Code	Name	Meaning
01H	Invalid command	The command code received by the upper computer is not allowed to be executed. The possible causes are as follows: <ul style="list-style-type: none"> The function code is applicable only on new devices and is not implemented on this device. The slave is in the faulty state when processing this request.

Code	Name	Meaning
02H	Invalid data address.	For the inverter, the data address in the request of the upper computer is not allowed. In particular, the combination of the register address and the number of the to-be-transmitted bytes is invalid.
03H	Invalid data value	The received data domain contains a value that is not allowed. The value indicates the error of the remaining structure in the combined request. Note: It does not mean that the data item submitted for storage in the register includes a value unexpected by the program.
04H	Operation failure	The parameter is set to an invalid value in the write operation. For example, a function input terminal cannot be set repeatedly.
05H	Password error	The password entered in the password verification address is different from that set in P07.00.
06H	Data frame error	The length of the data frame transmitted by the upper computer is incorrect, or in the RTU format, the value of the CRC check bit is inconsistent with the CRC value calculated by the lower computer.
07H	Parameter read-only	The parameter to be modified in the write operation of the upper computer is a read-only parameter.
08H	Parameter cannot be modified in running	The parameter to be modified in the write operation of the upper computer cannot be modified during the running of the inverter.
09H	Password protection	A user password is set, and the upper computer does not provide the password to unlock the system when performing a read or write operation. The error of "system locked" is reported.

The slave uses functional code fields and fault addresses to indicate it is a normal response or some error occurs (named as objection response). For normal responses, the slave shows corresponding function codes, digital address or sub-function codes as the response. For objection responses, the slave returns a code which equals the normal code, but the first byte is logic 1.

For example: when the master sends a message to the slave, requiring it to read a group of address data of the inverter function codes, there will be following function codes:

0 0 0 0 0 1 1 (Hex 03H)

For normal responses, the slave responds the same codes, while for objection responses, it will return:

1 0 0 0 0 1 1 (Hex 83H)

Besides the function codes modification for the objection fault, the slave will respond a byte of abnormal code which defines the error reason.

When the master receives the response for the objection, in a typical processing, it will send the message again or modify the corresponding order.

For example, set the "running command channel" of the inverter (P00.01, parameter address is 0001H) with the address of 01H to 03, the command is as following:

<u>01</u>	<u>06</u>	<u>00 01</u>	<u>00 03</u>	<u>98 0B</u>
Inverter address	Write command	Parameters address	Parameters data	CRC check

But the setting range of "running command channel" is 0–2, if it is set to 3, because the number is beyond the range, the inverter will return fault response message as follows.

<u>01</u>	<u>86</u>	<u>04</u>	<u>43 A3</u>
Inverter address	Abnormal response code	Fault code	CRC check

Abnormal response code 86H means the abnormal response to writing command 06H; the fault code is 04H. In the table above, its name is operation failed and its meaning is that the parameter setting in parameter writing is invalid. For example, the function input terminal cannot be set repeatedly.

8.5 Read/Write operation example

For details about the formats of the read and write commands, see section 8.3.

8.5.1 Examples of reading command 03H

Example 1: Read the state word 1 of the inverter whose address is 01H. See 8.4.2 Description of other function addresses in Modbus, the parameter address of the state word 1 of the inverter is 2100H.

RTU mode:

The command sent to the inverter:

<u>01</u>	<u>03</u>	<u>21 00</u>	<u>00 01</u>	<u>8E 36</u>
Inverter address	Read command	Parameters address	Data number	CRC check

If the response message is as follows.

<u>01</u>	<u>03</u>	<u>02</u>	<u>00 03</u>	<u>F8 45</u>
Inverter address	Read command	Data address	Data content	CRC check

ASCII mode:

The command sent to the inverter:

:	<u>01</u>	<u>03</u>	<u>21 00</u>	<u>00 01 DA</u>	<u>CR LF</u>
START	Inverter address	Read command	Parameters address	Data number	LRC check
					END

If the operation is successful, the following response is returned:

:	<u>01</u>	<u>03</u>	<u>02</u>	<u>00 03</u>	<u>F7</u>	<u>CR LF</u>
START	Inverter address	Read command	Byte number	Data content	LRC check	END

The data content is 0003H. From the table 1, the inverter stops.

8.5.2 Examples of writing command 06H

Example 1: Set the inverter whose address is 03H to be forward running. See 8.4.2 Description of other function addresses in Modbus, the address of "Communication control command" is 2000H, and 0001H indicates forward running.

Function instruction	Address definition	Data meaning instruction	R/W characteristics
Communication control command	2000H	0001H: Forward running	R/W
		0002H: Reverse running	
		0003H: Forward jogging	
		0004H: Reverse jogging	
		0005H: Stop	
		0006H: Coast to stop (emergency stop)	
		0007H: Fault reset	
		0008H: Jogging to stop	

RTU mode:

The command sent by the master:

<u>03</u>	<u>06</u>	<u>20 00</u>	<u>00 01</u>	<u>42 28</u>
Inverter address	Write command	Parameters address	Forward running	CRC check

If the operation is successful, the following response (same as the command transmitted from the master) is returned:

03 06 20 00 00 01 42 28
 Inverter Write Parameters Forward CRC check
 address command address running

ASCII mode:

The command sent to the inverter:

: 01 06 20 00 00 01 D6 CR LF
 START Inverter Write Parameters Data LRC END
 address command address number check

If the operation is successful, the following response (same as the command transmitted from the master) is returned:

: 01 06 20 00 00 01 D6 CR LF
 START Inverter Write Parameters Data LRC END
 address command address number check

Example 2: set the max output frequency of the inverter with the address of 03H as 100Hz.

Function code	Name	Description	Default	Modify
P00.03	Max. output frequency	Used to set the max. output frequency of the inverter. It is the basis of frequency setup and the acceleration/deceleration. Setting range: P00.04–400.00Hz	50.00Hz	⊙

See the figures behind the radix point, the fieldbus ratio value of max. output frequency (P00.03) is 100. 100Hz timed by 100 is 10000 and the corresponding hex is 2710H.

RTU mode:

The command sent by the master:

03 06 00 03 27 10 62 14
 Inverter Write Parameters Parameter data CRC check
 address command address

If the operation is successful, the following response (same as the command transmitted from the master) is returned:

03 06 00 03 27 10 62 14
 Inverter Write Parameters Parameter data CRC check
 address command address

ASCII mode:

The command sent to the inverter:

03 06 00 03 27 10 BD CR LF
 : Inverter Write Parameters Parameter LRC END
 START address command address data check

If the operation is successful, the following response (same as the command transmitted from the master) is returned:

03 06 00 03 27 10 BD CR LF
 : Inverter Write Parameters Parameter LRC END
 START address command address data check

8.5.3 Examples of continuous writing command10H

Example 1: Set the inverter whose address is 01H to be forward running at the frequency of 10Hz. See 8.4.2 Description of other function addresses in Modbus, the address of "Communication control command" is 2000H, and 0001H indicates forward running. The address of "Communication frequency setting" is 2001H, and 10 Hz is 03E8H in the hexadecimal form.

Function instruction	Address definition	Data meaning instruction	R/W characteristics
Communication control command	2000H	0001H: Forward running	R/W
		0002H: Reverse running	
		0003H: Forward jogging	
		0004H: Reverse jogging	
		0005H: Stop	
		0006H: Coast to stop (emergency stop)	
		0007H: Fault reset	
		0008H: Jogging to stop	
Address of communication setting	2001H	Communication setting frequency (0–Fmax (unit: 0.01Hz))	R/W
	2002H	PID given, range (0–1000, 1000 corresponds to100.0%)	

RTU mode:

The command sent to the inverter:

01 10 20 00 00 02 04 00 01 03 E8 3B 10
 Inverter Continuous Parameters Data Byte Forward 10Hz CRC check
 address writing address number number running

If the operation is successful, the following response is returned:

01 10 20 00 00 02 4A 08
 Inverter Continuous Parameters Data CRC check
 address writing address number

ASCII mode:

The command sent to the inverter:

: 01 10 20 00 00 02 04 00 01 03 E8 BD CR LF
 START Inverter Continuous Parameters Data Byte Forward 10Hz LRC
 address writing address number number running check END

If the operation is successful, the following response is returned:

: 01 10 20 00 00 02 CD CR LF
 START Inverter Continuous Parameters Data LRC
 address writing address number check END

Example 2: Set ACC time of 01H inverter as 10s and DEC time as 20s.

P00.11	ACC time 1	Setting range of P00.11 and P00.12: 0.0–3600.0s	Depend on model	○
P00.12	DEC time 1		Depend on model	○

The corresponding address of P00.11 is 000B, the ACC time of 10s corresponds to 0064H, and the DEC time of 20s corresponds to 00C8H.

RTU mode:

The command sent to the inverter:

01 10 00 0B 00 02 04 00 64 00 C8 F2 55
 Inverter Continuous Parameters Data Byte 10s 20s CRC check
 address writing address number number

If the operation is successful, the following response is returned:

01 10 00 0B 00 02 30 0A
 Inverter Continuous Parameters Data CRC check
 address writing address number

ASCII mode:

The command sent to the inverter:

: 01 10 00 0B 00 02 04 00 64 00 C8 B2 CR LF
 START Inverter Continuous Parameters Data Number 10s 20s LRC
 address writing address number of bytes check END

If the operation is successful, the following response is returned:

:	<u>01</u>	<u>10</u>	<u>00 0B</u>	<u>00 02</u>	<u>E2</u>	<u>CR LF</u>
START	Inverter address	Continuous writing command	Parameters address	Data number	LRC check	END

Note: The blank in the above command is for illustration. The blank cannot be added in the actual application unless the upper monitor can remove the blank by themselves.

8.6 Common communication faults

Common communication faults include the following:

- ✧ No response is returned.
- ✧ The inverter returns an exception response.

Possible causes of no response include the following:

- ✧ The serial port is set incorrectly. For example, the converter uses the serial port COM1, but COM2 is selected for the communication.
- ✧ The settings of the baud rates, data bits, stop bits, and check bits are inconsistent with those set on the inverter.
- ✧ The positive pole (+) and negative pole (-) of the RS485 bus are connected reversely.
- ✧ The RS485 wire cap on the terminal board of the inverter is not connected. This wire cap is at the back of the terminal block.

Appendix A Options

A.1 Boost module

The pump inverters $\leq 2.2\text{KW}$ support the installation of the boost module (PP100-3R2-PV) to improve the utilization of the solar modules. The figure below shows the wiring method.

1. Connect PV+ and PV- of the boost module to the positive input terminal and negative input terminal of the modules respectively.
2. Connect the output terminals (+) and (-) of the boost module to the input terminals (+) and (-) of the pump inverter.
3. Connect 422-communication receiving terminal RX of the boost module to 422-communication sending terminal TX of the pump inverter. Connect 422-communication sending terminal TX of the boost module to 422-communication receiving terminal RX of the pump inverter. Use twisted pairs for wiring.
4. If the wiring is connected, switch on the breaker Q1 at the DC side for automotive running.

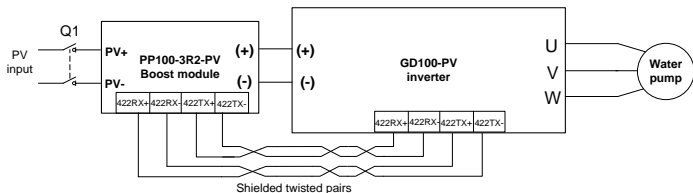

Figure A-1 Connection between the boost module and the inverter

Boost module specifications:

Model	PP100-3R2-PV
Input side	
Max. input power (W)	3200
Max. DC voltage (V)	600
Start voltage (V)	80
Min. working voltage (V)	70
Max. input current (A)	12
Output side	
Output voltage (V)	220V inverter: 350; 380V inverter: 570

Status indicator description:

Display state	Description
Green LED flickering	The boost module has been powered on, and the control circuit is working.
Green LED on	The boost module is running.
Red LED on	The boost module is faulty.

The figure below shows the installation dimension drawing of the boost module.

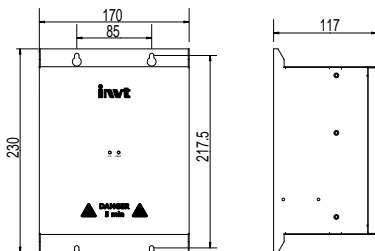

Figure A-2 Installation dimensions of the boost module

A.2 GPRS module and monitoring APP

The pump inverter supports an optional GPRS module to implement remote monitoring, and the GPRS module connects to the inverters through 485 communication. The running state of the inverter can be monitored in real time on the APP in the mobile phone or web page.

Method for connecting the GPRS module to the inverter:

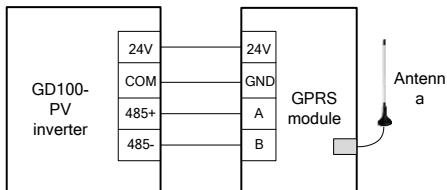

Figure A-3 Connection between the GPRS module and the inverter

For details, see the *GPRS/GPS Adaptor Operation Manual* which comes with the GPRS module or contact the local INVT office. Provide the model and serial number of the product you query about.

A.3 Cable

A.3.1 Power cable

The sizes of the input power cables and motor cables must comply with local regulations.

Note: If the electrical conductivity of the motor cable shield layer does not meet the requirements, a separate PE conductor must be used.

A.3.2 Control cable

A relay cable needs to carry the metal braided shield layer.

Keypads need to be connected by using network cables. In complicated electromagnetic environments, shielded network cables are recommended.

A shielded twisted-pair cable is recommended for a communication cable.

Note:

- Analog signals and digital signals cannot share a same cable, and their cables must be routed separately.
- Before connecting the input power cable of the inverter, check the insulation conditions of the cable according to local regulations.

Recommended power cable sizes for standard inverter models:

Model	Recommended cable size (mm ²)		Terminal screw	Tightening torque (Nm)
	(+)/(-), R/S/T, U/V/W	PE		
GD100-0R4G-S2-PV	1.5	1.5	M4	0.8
GD100-0R7G-S2-PV	1.5	1.5	M4	0.8
GD100-0R4G-SS2-PV	1.5	1.5	M4	0.8
GD100-0R7G-4-PV	1.5	1.5	M4	0.8
GD100-1R5G-4-PV	1.5	1.5	M4	0.8
GD100-2R2G-4-PV	1.5	1.5	M4	0.8
GD100-1R5G-S2-PV	2.5	2.5	M4	0.8
GD100-2R2G-S2-PV	2.5	2.5	M4	0.8
GD100-0R7G-SS2-PV	2.5	2.5	M4	0.8
GD100-1R5G-SS2-PV	2.5	2.5	M4	0.8
GD100-2R2G-SS2-PV	2.5	2.5	M4	0.8
GD100-004G-4-PV	2.5	2.5	M4	1.2–1.5
GD100-5R5G-4-PV	2.5	2.5	M4	1.2–1.5
GD100-1R5G-2-PV	2.5	2.5	M4	1.2–1.5
GD100-2R2G-2-PV	2.5	2.5	M4	1.2–1.5
GD100-7R5G-4-PV	4	4	M5	2–2.5
GD100-004G-2-PV	4	4	M5	2–2.5

Model	Recommended cable size (mm ²)		Terminal screw	Tightening torque (Nm)
	(+)(-), R/S/T, U/V/W	PE		
GD100-011G-4-PV	6	6	M5	2–2.5
GD100-5R5G-2-PV	6	6	M5	2–2.5
GD100-015G-4-PV	10	10	M5	2–2.5
GD100-7R5G-2-PV	10	10	M5	2–2.5
GD100-018G-4-PV	16	16	M5	2–2.5
GD100-022G-4-PV	25	16	M5	2–2.5
GD100-030G-4-PV	25	16	M6	4–6
GD100-037G-4-PV	35	16	M6	4–6
GD100-045G-4-PV	35	16	M8	10
GD100-055G-4-PV	50	25	M8	10
GD100-075G-4-PV	70	35	M8	10
GD100-090G-4-PV	95	50	M12	31–40
GD100-110G-4-PV	120	70	M12	31–40
GD100-132G-4-PV	185	95	M12	31–40
GD100-160G-4-PV	240	95	M12	31–40
GD100-185G-4-PV	120*2P	150	M12	31–40
GD100-200G-4-PV	120*2P	150	M12	31–40
GD100-220G-4-PV	95*2P	95	M12	31–40
GD100-250G-4-PV	95*2P	95	M12	31–40
GD100-280G-4-PV	150*2P	150	M12	31–40
GD100-315G-4-PV	150*2P	150	M12	31–40
GD100-355G-4-PV	185*2P	185	M12	31–40
GD100-400G-4-PV	150*3P	120*2P	M12	31–40
GD100-450G-4-PV	185*3P	120*2P	M12	31–40
GD100-500G-4-PV	185*3P	120*2P	M12	31–40

Note:

- For the cable selection for IP54 models, see the cables applicable to the models with the same power as model IP54 in this table.
- The cables recommended for the main circuit can be used in scenarios where the ambient temperature is lower than 40°C, the wiring distance is shorter than 100 m, and the current is the rated current.
- If a control cable and power cable must cross each other, ensure that the angle between them is 90 degrees.
- If the inside of motor is moist, the insulation resistance is reduced. If you suspect the inside of motor is moist, dry and re-measure the motor.

A.4 Reactor

When the distance between the inverter and motor is longer than 50 m, the parasitic capacitance between the long cable and ground may cause large leakage current, and overcurrent protection of the inverter may be frequently triggered. To prevent this from happening and avoid damage to the motor insulator, compensation must be made by adding an output reactor. When an inverter is used to drive multiple motors, take the total length of the motor cables (that is, sum of the lengths of the motor cables) into account. When the total length is longer than 50 m, an output reactor must be added on the output side of the inverter. If the distance between the inverter and motor is 50 m to 100 m, select the reactor according to the following table. If the distance is longer than 100 m, contact INVT's technical support technicians.

Output reactor model selection:

Inverter model	Output reactor
GD100-1R5G-2-PV	OCL2-004-4
GD100-2R2G-2-PV	OCL2-004-4
GD100-004G-2-PV	OCL2-5R5-4
GD100-5R5G-2-PV	OCL2-7R5-4
GD100-7R5G-2-PV	OCL2-015-4
GD100-0R7G-4-PV	OCL2-1R5-4
GD100-1R5G-4-PV	OCL2-1R5-4
GD100-2R2G-4-PV	OCL2-2R2-4
GD100-004G-4-PV	OCL2-004-4
GD100-5R5G-4-PV	OCL2-5R5-4
GD100-7R5G-4-PV	OCL2-7R5-4
GD100-011G-4-PV	OCL2-011-4
GD100-015G-4-PV	OCL2-015-4
GD100-018G-4-PV	OCL2-018-4
GD100-022G-4-PV	OCL2-022-4
GD100-030G-4-PV	OCL2-037-4
GD100-037G-4-PV	OCL2-037-4
GD100-045G-4-PV	OCL2-045-4
GD100-055G-4-PV	OCL2-055-4
GD100-075G-4-PV	OCL2-075-4
GD100-090G-4-PV	OCL2-110-4
GD100-110G-4-PV	OCL2-110-4
GD100-132G-4-PV	OCL2-160-4
GD100-160G-4-PV	OCL2-200-4
GD100-185G-4-PV	OCL2-200-4

Inverter model	Output reactor
GD100-200G-4-PV	OCL2-200-4
GD100-220G-4-PV	OCL2-280-4
GD100-250G-4-PV	OCL2-280-4
GD100-280G-4-PV	OCL2-350-4
GD100-315G-4-PV	OCL2-350-4
GD100-355G-4-PV	OCL2-400-4
GD100-400G-4-PV	OCL2-400-4
GD100-450G-4-PV	OCL2-500-4
GD100-500G-4-PV	OCL2-500-4

Note:

- The rated output voltage drop of output reactors is $1\% \pm 15\%$.
- All the options in the preceding table are externally configured. You need to specify whether the options are externally configured in your purchase order.

A.5 Filter

Goodrive100-PV series inverters of $\geq 4\text{kW}$ contain built-in C3 filters. You can use the jumper J10 to determine whether to connect it.

Connection method: Open the lower cover, find the location of J10, and insert the jumper terminals delivered with the inverter.

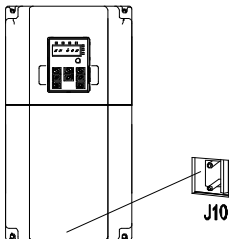

Note: The input EMI meets the C3 requirements after a filter is configured.

Appendix B Recommended solar module configuration

B.1 Recommended solar module configuration for solar pump inverters

Solar pump inverter model	Open-circuit voltage class of solar module			
	37±1V		45±1V	
	Module power ± 5Wp	Modules per string * Strings	Module power ± 5Wp	Modules per string * Strings
GD100-0R4G-SS2-PV	250	11*1	300	9*1
GD100-0R7G-SS2-PV	250	11*1	300	9*1
GD100-1R5G-SS2-PV	250	11*1	300	9*1
GD100-2R2G-SS2-PV	250	11*1	300	9*1
GD100-0R4G-S2-PV	250	11*1	300	9*1
GD100-0R7G-S2-PV	250	11*1	300	9*1
GD100-1R5G-S2-PV	250	11*1	300	9*1
GD100-2R2G-S2-PV	250	11*1	300	9*1
GD100-1R5G-2-PV	250	11*1	300	9*1
GD100-2R2G-2-PV	250	11*1	300	9*1
GD100-004G-2-PV	250	11*2	300	9*2
GD100-5R5G-2-PV	250	11*3	300	9*3
GD100-7R5G-2-PV	250	11*4	300	9*4
GD100-0R7G-4-PV	250	18*1	300	15*1
GD100-1R5G-4-PV	250	18*1	300	15*1
GD100-2R2G-4-PV	250	18*1	300	15*1
GD100-004G-4-PV	250	20*1	300	16*1
GD100-5R5G-4-PV	250	18*2	300	15*2
GD100-7R5G-4-PV	250	18*2	300	15*2
GD100-011G-4-PV	250	18*3	300	15*3
GD100-015G-4-PV	250	18*4	300	15*4
GD100-018G-4-PV	250	18*5	300	15*5
GD100-022G-4-PV	250	18*6	300	15*6
GD100-030G-4-PV	250	18*8	300	15*8
GD100-037G-4-PV	250	18*9	300	15*9
GD100-045G-4-PV	250	18*11	300	15*11
GD100-055G-4-PV	250	18*14	300	15*14
GD100-075G-4-PV	250	18*19	300	15*19

Solar pump inverter model	Open-circuit voltage class of solar module			
	37±1V		45±1V	
	Module power ± 5Wp	Modules per string * Strings	Module power ± 5Wp	Modules per string * Strings
GD100-090G-4-PV	250	18*22	300	15*22
GD100-110G-4-PV	250	18*27	300	15*27
GD100-132G-4-PV	250	18*38	300	15*38
GD100-160G-4-PV	250	18*46	300	15*46
GD100-185G-4-PV	250	18*53	300	15*53
GD100-200G-4-PV	250	18*57	300	15*57
GD100-220G-4-PV	250	18*63	300	15*
GD100-250G-4-PV	250	18*	300	15*
GD100-280G-4-PV	250	18*	300	15*
GD100-315G-4-PV	250	18*	300	15*
GD100-355G-4-PV	250	18*	300	15*
GD100-400G-4-PV	250	18*	300	15*
GD100-450G-4-PV	250	18*	300	15*
GD100-500G-4-PV	250	18*	300	15*

B.2 Recommended solar module configuration for inverters with boost module

PP100-3R2-PV + Solar pump inverter	Max. DC input current	Open-circuit voltage class of solar module			
		37±1V		45±1V	
	(A)	Module power ± 5Wp	Modules per string * Strings	Module power ± 5Wp	Modules per string * Strings
GD100-0R4G-SS2-PV	12	250	4*1	300	3*1
GD100-0R7G-SS2-PV	12	250	5*1	300	4*1
GD100-1R5G-SS2-PV	12	250	8*1	300	7*1
GD100-0R4G-S2-PV	12	250	4*1	300	3*1
GD100-0R7G-S2-PV	12	250	5*1	300	4*1
GD100-1R5G-S2-PV	12	250	8*1	300	7*1
GD100-1R5G-2-PV	12	250	8*1	300	7*1

PP100-3R2-PV + Solar pump inverter	Max. DC input current	Open-circuit voltage class of solar module			
		37±1V		45±1V	
	(A)	Module power ± 5Wp	Modules per string * Strings	Module power ± 5Wp	Modules per string * Strings
GD100-2R2G-2-PV	12	250	13*1	300	11*1
GD100-0R7G-4-PV	12	250	5*1	300	4*1
GD100-1R5G-4-PV	12	250	8*1	300	7*1
GD100-2R2G-4-PV	12	250	13*1	300	11*1

Appendix C Power frequency & PV switching solution

C.1 Solution introduction

Generally, inverters do not allow simultaneous connection of power frequency and PV. If such simultaneous connection is required, switching control circuit needs to be configured externally. The following figure shows a solution for reference.

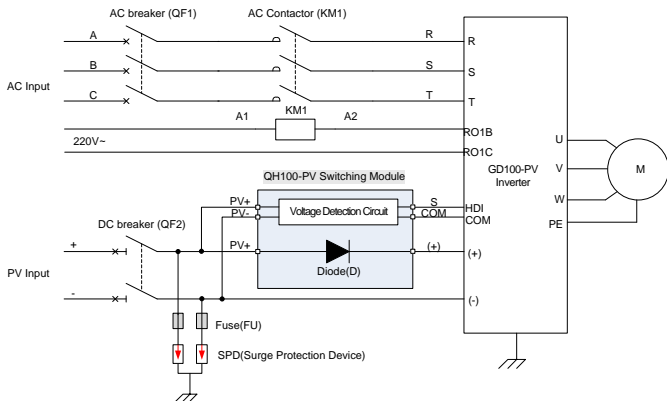

Figure C-1 Inverter power frequency & PV switching solution

See C.1.1 for specifications and model selection of QH100-PV switching module, whose necessary low-voltage apparatuses include QF1, KM1, QF2, FU, and SPD. See section C.1.2 for model selection information.

C.1.1 QH100-PV switching module

C.1.1.1 Models and specification

QH100 - 055A - 4 - PV

① ② ③ ④

Field	Sign	Description	Content
Product series abbreviation	①	Product series abbreviation	QH100 series power frequency & PV switching module

Field	Sign	Description	Content
Rated current	②	Power range for adaptive inverter	055A—applies to inverters of $\leq 15\text{kW}$ 110A—applies to inverters of 18.5–37kW
Voltage class	③	Voltage class	4: AC 3PH 380V (-15%)–440 (+10%) 2: AC 3PH 220V (-15%)–240 (+10%)
Industry code	④	Industry code	PV: Photovoltaic water pump series products

C.1.1.2 Terminal description of QH100-PV switching module

Terminal	Terminal name	Description
PV +	PV input	Voltage detection board input, connecting to anode of PV input.
PV –	PV input	Voltage detection board input, connecting to cathode of PV input.
(+)	Switching module output	Cathode of diode module, connecting to (+) of the inverter.
S, COM	Voltage detection signal	ON/OFF signal, corresponding PV voltage greater/less than preset threshold, connecting to terminals HDI and COM of the inverter.

C.1.1.3 Installation dimensions

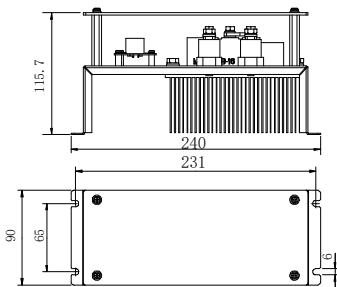

Figure C–2 Installation dimensions of the switching module (unit: mm)

Note: To ensure reliable operation of this product, external ventilation and heat dissipation measures are required.

C.1.2 Model selection reference for low-voltage apparatuses

Model	AC breaker (A)	DC breaker	AC contactor (A)	SPD	Fuse	Diode I_{FAV}/V_{RRM}		
GD100-0R4G-S2-PV-AS	16	16A/ 1000VDC	16	Type II, 1000V DC	30A	25A/16 00V		
GD100-0R7G-S2-PV-AS	16		16					
GD100-0R4G-SS2-PV-AS	16		16					
GD100-1R5G-2-PV-AS	16		16					
GD100-1R5G-S2-PV-AS	25		25					
GD100-0R7G-SS2-PV-AS	16		16					
GD100-2R2G-S2-PV-AS	40		40					
GD100-1R5G-SS2-PV-AS	25		25					
GD100-2R2G-SS2-PV-AS	40		40					
GD100-0R7G-4-PV-AS	10		12					
GD100-1R5G-4-PV-AS	10		12					
GD100-2R2G-4-PV-AS	10		12					
GD100-004G-4-PV-AS	25		25					
GD100-5R5G-4-PV-AS	25		25					
GD100-2R2G-2-PV-AS	25	25A/ 1000VDC	25			55A/ 1600V		
GD100-004G-2-PV-AS	25		25					
GD100-7R5G-4-PV-AS	40		40					
GD100-5R5G-2-PV-AS	40	63A/ 1000VDC	40				110A/ 1600V	
GD100-011G-4-PV-AS	50		50					
GD100-7R5G-2-PV-AS	50		50					
GD100-015G-4-PV-AS	63		63					
GD100-018G-4-PV-AS	63	100A/ 1000VDC	63					110A/ 1600V
GD100-022G-4-PV-AS	100		95					
GD100-030G-4-PV-AS	100		95					
GD100-037G-4-PV-AS	125	125A/ 1000VDC	115	110A/ 1600V				

Model	AC breaker (A)	DC breaker	AC contactor (A)	SPD	Fuse	Diode I_{FAV}/V_{RRM}
GD100-045G-4-PV-AS	200	160A/ 1000VDC	170			160A/ 1600V
GD100-055G-4-PV-AS	200	250A/ 1000VDC	170			250A/ 1600V
GD100-075G-4-PV-AS	250		205			
GD100-090G-4-PV-AS	315	350A/ 1000VDC	245			350A/ 1600V
GD100-110G-4-PV-AS	350		265			
GD100-132G-4-PV-AS	350	400A/ 1000VDC	330			400A/ 1600V
GD100-160G-4-PV-AS	400	550A/ 1000VDC	400			550A/ 1600V
GD100-185G-4-PV-AS	500		500			
GD100-200G-4-PV-AS	500	600A/ 1000VDC	500			600A/ 1600V
GD100-220G-4-PV-AS	630	630A/ 1000VDC	630			630A/ 1000V
GD100-250G-4-PV-AS						
GD100-280G-4-PV-AS	800	800A/ 1000VDC	800			800A/ 1000V
GD100-315G-4-PV-AS						
GD100-355G-4-PV-AS	1000	1000A/ 1000VDC	1000			1000A/ 1000V
GD100-400G-4-PV-AS						
GD100-450G-4-PV-AS	1250	1250A/ 1000VDC	1250			1250A/ 1000V
GD100-500G-4-PV-AS						

C.2 IP54 protection-level inverters

INVT provides IP54 protection-level inverters, which are divided into two types: One type implements auto power frequency & PV switching and the other type does not implement auto switching.

The following figure shows the dimensions of the inverter.

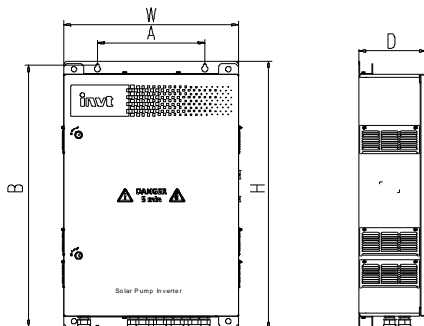

Figure C-3 Dimensions of IP54 inverter

Dimensions of IP54 inverter (unit: mm):

Power (kW)	Model	W	H	D	A	B
37	GD100-037G-45-PV-AS	650	1000	250	400	975
30	GD100-030G-45-PV-AS					
22	GD100-022G-45-PV-AS					
18.5	GD100-018G-45-PV-AS					
15	GD100-015G-45-PV-AS	550	900	225	400	875
11	GD100-011G-45-PV-AS					
7.5	GD100-7R5G-45-PV-AS					
	GD100-7R5G-25-PV-AS					
5.5	GD100-5R5G-45-PV-AS					
	GD100-5R5G-25-PV-AS					
4	GD100-004G-45-PV-AS					
	GD100-004G-25-PV-AS					
2.2	GD100-2R2G-45-PV-AS	550	700	200	400	675
	GD100-2R2G-S25-PV-AS					
	GD100-2R2G-SS25-PV-AS					

Power (kW)	Model	W	H	D	A	B
1.5	GD100-1R5G-45-PV-AS					
	GD100-1R5G-S25-PV-AS					
	GD100-1R5G-SS25-PV-AS					
0.75	GD100-0R7G-45-PV-AS					
	GD100-0R7G-S25-PV-AS					
	GD100-0R7G-SS25-PV-AS					
0.4	GD100-0R4G-S25-PV-AS					
	GD100-0R4G-SS25-PV-AS					

Note:

- The inverters that do not implement auto switching do not have the suffix -AS.
- The inverters $\leq 2.2\text{kW}$ are equipped with the boost module as standard configuration, supporting auto switching.
- For -S25 and -SS25 models equipped with the boost module, the DC input voltage cannot be greater than 440V. For -45 models equipped with the boost module, the DC input voltage cannot be greater than 600V.

C.3 Wiring description

The following figures show the wiring terminals of IP54 inverters.

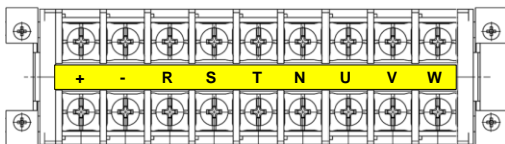

Figure C-4 Wiring terminals of 4-37kW models

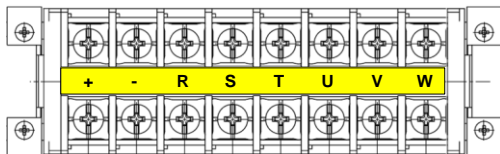
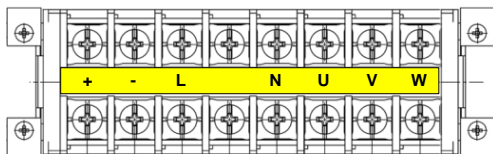



Figure C-5 Wiring terminals of -4 models for inverters $\leq 2.2\text{kW}$

Figure C-6 Wiring terminals of -S2/-SS2 models for inverters $\leq 2.2\text{kW}$

Terminal function description:

Symbol	Terminal name	Description
R, S, T	AC input	3PH 380V/220V AC input terminals, connected to the grid
N		Neutral wire. For inverter models of 4-37kW, it is required to use three-phase four-wire distribution system and connect the neutral wire to terminal N.
L, N	AC input	1PH 220V AC input terminals, connected to the grid
(+), (-)	PV DC input	Input terminals of photovoltaic panels.
U, V, W	Inverter output	3PH/1PH AC output terminals, connected to pump motor. Note: 1PH motors must connect to terminals U and W.
	Safety protection grounding	Grounding terminal for safe protection; each machine must be properly grounded. Note: The grounding terminal is located at the bottom of the chassis.

C.4 Parameter setting method

Connect the external PV voltage detection signal to HDI terminal (auto switching by default). Ensure that the PV voltage detection threshold is 300V for the -4 models and it is 200V for the -2/-S2/-SS2 models.

After the correct connection, set P15.32 to 0.

Appendix D Dimension drawings

D.1 External keypad structure

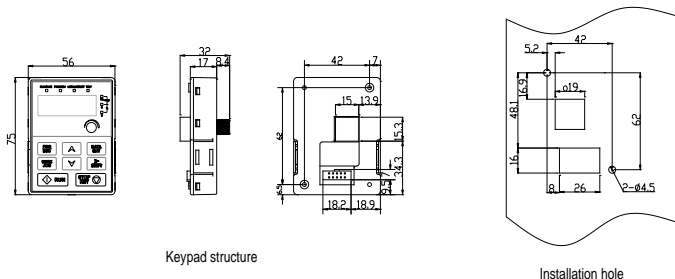

Keypad structure

Installation hole

Note: The inverter models of 380V 2.2kW and lower support an optional external keypad, and the keypad of inverter models of 380V 4kW and higher can be installed on another device.

If the keypad is externally installed on an optional bracket, it can be 20 meters away from the inverter at most.

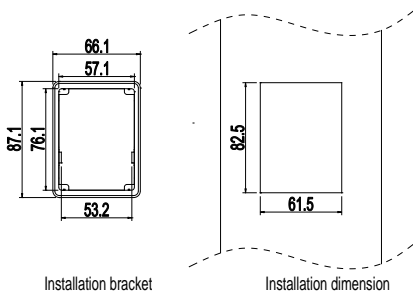

Installation bracket

Installation dimension

D.2 Dimensions of 0.4-2.2kW models

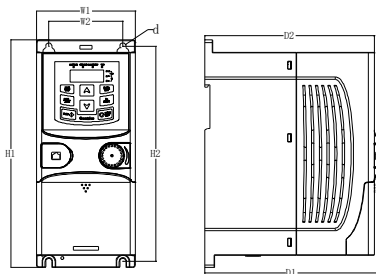

Figure D-1 Wall mounting

Table D-1 Wall-mounting dimensions (unit: mm)

Model	W1	W2	H1	H2	D1	D2	Installation hole diameter (d)
GD100-0R4G-S2-PV	80.0	60.0	160.0	150.0	123.5	120.3	Ø 5
GD100-0R7G-S2-PV	80.0	60.0	160.0	150.0	123.5	120.3	Ø 5
GD100-0R4G-SS2-PV	80.0	60.0	160.0	150.0	123.5	120.3	Ø 5
GD100-1R5G-S2-PV	80.0	60.0	185.0	175.0	140.5	137.3	Ø 5
GD100-2R2G-S2-PV	80.0	60.0	185.0	175.0	140.5	137.3	Ø 5
GD100-0R7G-SS2-PV	80.0	60.0	185.0	175.0	140.5	137.3	Ø 5
GD100-1R5G-SS2-PV	80.0	60.0	185.0	175.0	140.5	137.3	Ø 5
GD100-2R2G-SS2-PV	80.0	60.0	185.0	175.0	140.5	137.3	Ø 5
GD100-0R7G-4-PV	80.0	60.0	185.0	175.0	140.5	137.3	Ø 5
GD100-1R5G-4-PV	80.0	60.0	185.0	175.0	140.5	137.3	Ø 5
GD100-2R2G-4-PV	80.0	60.0	185.0	175.0	140.5	137.3	Ø 5

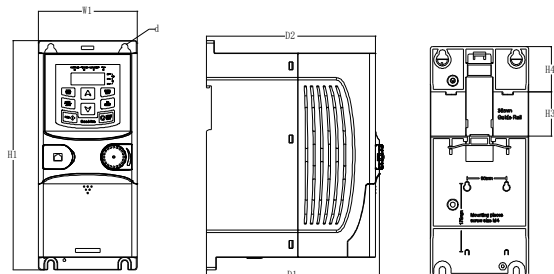

Figure D-2 Rail mounting

Table D-2 Rail-mounting dimensions (unit: mm)

Model	W1	H1	H3	H4	D1	D2	Installation hole diameter (d)
GD100-0R4G-S2-PV	80.0	160.0	35.4	36.6	123.5	120.3	Ø 5
GD100-0R7G-S2-PV	80.0	160.0	35.4	36.6	123.5	120.3	Ø 5
GD100-0R4G-SS2-PV	80.0	160.0	35.4	36.6	123.5	120.3	Ø 5
GD100-1R5G-S2-PV	80.0	185.0	35.4	36.6	140.5	137.3	Ø 5
GD100-2R2G-S2-PV	80.0	185.0	35.4	36.6	140.5	137.3	Ø 5
GD100-0R7G-SS2-PV	80.0	185.0	35.4	36.6	140.5	137.3	Ø 5
GD100-1R5G-SS2-PV	80.0	185.0	35.4	36.6	140.5	137.3	Ø 5
GD100-2R2G-SS2-PV	80.0	185.0	35.4	36.6	140.5	137.3	Ø 5
GD100-0R7G-4-PV	80.0	185.0	35.4	36.6	140.5	137.3	Ø 5
GD100-1R5G-4-PV	80.0	185.0	35.4	36.6	140.5	137.3	Ø 5
GD100-2R2G-4-PV	80.0	185.0	35.4	36.6	140.5	137.3	Ø 5

D.3 Dimensions of 1.5-500kW models

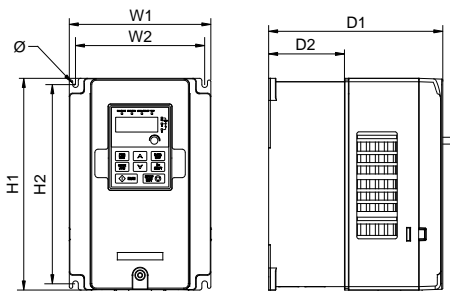

Figure D-3 Wall mounting

Table D-3 Wall-mounting dimensions (unit: mm)

Model	W1	W2	H1	H2	D1	D2	Installation hole diameter (d)
GD100-1R5G-2-PV	146.0	131.0	256.0	243.5	167.0	84.5	Ø 6
GD100-2R2G-2-PV	146.0	131.0	256.0	243.5	167.0	84.5	Ø 6
GD100-004G-4-PV	146.0	131.0	256.0	243.5	167.0	84.5	Ø 6
GD100-5R5G-4-PV	146.0	131.0	256.0	243.5	167.0	84.5	Ø 6
GD100-7R5G-4-PV	170.0	151.0	320.0	303.5	196.3	113.0	Ø 6
GD100-011G-4-PV	170.0	151.0	320.0	303.5	196.3	113.0	Ø 6
GD100-015G-4-PV	170.0	151.0	320.0	303.5	196.3	113.0	Ø 6
GD100-004G-2-PV	170.0	151.0	320.0	303.5	196.3	113.0	Ø 6
GD100-5R5G-2-PV	170.0	151.0	320.0	303.5	196.3	113.0	Ø 6
GD100-7R5G-2-PV	170.0	151.0	320.0	303.5	196.3	113.0	Ø 6
GD100-018G-4-PV	200.0	185.0	340.6	328.6	184.3	104.5	Ø 6
GD100-022G-4-PV	200.0	185.0	340.6	328.6	184.3	104.5	Ø 6
GD100-030G-4-PV	250.0	230.0	400.0	380.0	202.0	123.5	Ø 6
GD100-037G-4-PV	250.0	230.0	400.0	380.0	202.0	123.5	Ø 6
GD100-045G-4-PV	282.0	160.0	560.0	542.4	238.0	138.0	Ø 9
GD100-055G-4-PV	282.0	160.0	560.0	542.4	238.0	138.0	Ø 9

Model	W1	W2	H1	H2	D1	D2	Installation hole diameter (d)
GD100-075G-4-PV	282.0	160.0	560.0	542.4	238.0	138.0	Ø 9
GD100-090G-4-PV	338.0	200.0	554.0	534.0	326.2	--	Ø 9.5
GD100-110G-4-PV	338.0	200.0	554.0	534.0	326.2	--	Ø 9.5
GD100-132G-4-PV	500.0	360.0	870.0	850.0	360.0	--	Ø 11
GD100-160G-4-PV	500.0	360.0	870.0	850.0	360.0	--	Ø 11
GD100-185G-4-PV	500.0	360.0	870.0	850.0	360.0	--	Ø 11
GD100-200G-4-PV	500.0	360.0	870.0	850.0	360.0	--	Ø 11

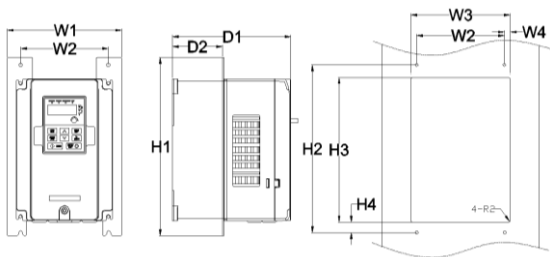

Figure D-4 Flange installation

Table D-4 Flange-mounting dimensions (unit: mm)

Model	W1	W2	W3	W4	H1	H2	H3	H4	D1	D2	Installation hole diameter	Nut specs
GD100-004G-4-PV	170.2	131	150	9.5	292	276	260	6	167	84.5	Ø 6	M5
GD100-5R5G-4-PV	170.2	131	150	9.5	292	276	260	6	167	84.5	Ø 6	M5
GD100-7R5G-4-PV	191.2	151	174	11.5	370	351	324	12	196.3	113	Ø 6	M5
GD100-011G-4-PV	191.2	151	174	11.5	370	351	324	12	196.3	113	Ø 6	M5
GD100-015G-4-PV	191.2	151	174	11.5	370	351	324	12	196.3	113	Ø 6	M5
GD100-1R5G-2-PV	170.2	131	150	9.5	292	276	260	6	167	84.5	Ø 6	M5
GD100-2R2G-2-PV	170.2	131	150	9.5	292	276	260	6	167	84.5	Ø 6	M5
GD100-004G-2-PV	191.2	151	174	11.5	370	351	324	12	196.3	113	Ø 6	M5
GD100-5R5G-2-PV	191.2	151	174	11.5	370	351	324	12	196.3	113	Ø 6	M5
GD100-7R5G-2-PV	191.2	151	174	11.5	370	351	324	12	196.3	113	Ø 6	M5

Model	W1	W2	W3	W4	H1	H2	H3	H4	D1	D2	Installation hole diameter	Nut specs
GD100-018G-4-PV	266	250	224	13	371	250	350.6	20.3	184.6	104	Ø 6	M5
GD100-022G-4-PV	266	250	224	13	371	250	350.6	20.3	184.6	104	Ø 6	M5
GD100-030G-4-PV	316	300	274	13	430	300	410	55	202	118.3	Ø 6	M5
GD100-037G-4-PV	316	300	274	13	430	300	410	55	202	118.3	Ø 6	M5
GD100-045G-4-PV	352	332	306	13	580	400	570	80	238	133.8	Ø 9	M8
GD100-055G-4-PV	352	332	306	13	580	400	570	80	238	133.8	Ø 9	M8
GD100-075G-4-PV	352	332	306	13	580	400	570	80	238	133.8	Ø 9	M8
GD100-090G-4-PV	418.5	361	389.5	14.2	600	559	370	108.5	329.5	149.5	Ø 9.5	M8
GD100-110G-4-PV	418.5	361	389.5	14.2	600	559	370	108.5	329.5	149.5	Ø 9.5	M8
GD100-132G-4-PV	500	360	480	60	870	850	796	37	358	178.5	Ø 11	M10
GD100-160G-4-PV	500	360	480	60	870	850	796	37	358	178.5	Ø 11	M10
GD100-185G-4-PV	500	360	480	60	870	850	796	37	358	178.5	Ø 11	M10
GD100-200G-4-PV	500	360	480	60	870	850	796	37	358	178.5	Ø 11	M10
GD100-220G-4-PV	750	230	714	680	1410	1390	/	/	380	150	Ø 6	M5
GD100-250G-4-PV												
GD100-280G-4-PV												
GD100-315G-4-PV												
GD100-355G-4-PV	620	230	573	/	1700	1678	/	/	560	240	Ø22/12	M20/10
GD100-400G-4-PV												
GD100-450G-4-PV												
GD100-500G-4-PV												

Note: The flange mounting plate shall be used for flange mounting.

Appendix E Further information

E.1 Product and service queries

If you have any queries about the product, contact the local INVT office. Please provide the model and serial number of the product you query about. You can visit www.invt.com to find a list of INVT offices.

E.2 Feedback of INVT inverter manuals

Your comments on our manuals are welcome. Visit www.invt.com, directly contact online service personnel or choose **Contact Us** to obtain contact information.

E.3 Document library on the Internet

You can find manuals and other product documents in PDF format on the Internet. Visit www.invt.com and choose **Support > Download**.



E-mail: overseas@invt.com.cn Website: www.invt.com

The products are owned by **Shenzhen INVT Electric Co.,Ltd.**

Two companies are commissioned to manufacture: (For product code, refer to the 2nd/3rd place of S/N on the name plate.)

Shenzhen INVT Electric Co.,Ltd. (origin code: 01)

Address: INVT Guangming Technology Building, Songbai Road,
Matian, Guangming District, Shenzhen, China

INVT Power Electronics (Suzhou) Co.,Ltd. (origin code: 06)

Address: No. 1 Kunlun Mountain Road, Science & Technology
Town, Gaoxin District, Suzhou, Jiangsu, China

Industrial Automation: HMI

Elevator Intelligent Control System

PLC

VFD

Servo System

Rail Transit Traction System

Energy & Power:

UPS

DCIM

Solar Inverter

SVG

New Energy Vehicle Powertrain System

New Energy Vehicle Charging System

New Energy Vehicle Motor



66001-00414

Copyright© INVT.

Manual information may be subject to change without prior notice.

202307 (V1.8)