

IVC1L-2AD Analog Input Module

User Manual

Note:

To reduce the chance of accident, please carefully read the operating instructions and safety precautions prior to use. Only adequately trained personnel shall install or operate this product. In operation, strict compliance with applicable safety rules in the industry, the operating instructions and safety precautions in this book is required.

1 Port Description

1.1 Port

The extension port and user port of IVC1L-2AD are both protected by a cover, as shown in Figure 1-1.

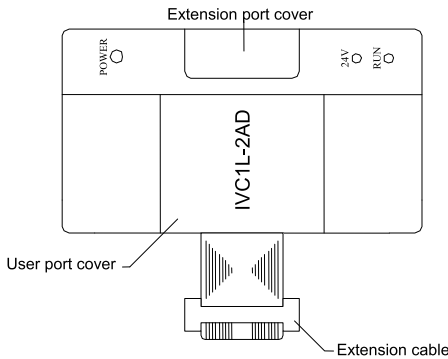

Figure 1-1 IVC1L-2AD appearance

Removing the covers reveals the extension port and user port, as shown in Figure 1-2.

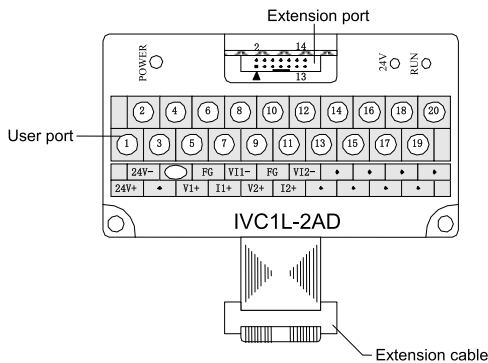

Figure 1-2 IVC1L-2AD ports

The extension cable connects IVC1L-2AD to the system, while the extension port connects IVC1L-2AD to another extension module of the system. For details on connection, see 1.2 Connecting Into System.

The user port of IVC1L-2AD is described in Table 1-1.

Table 1-1 User port description

Terminal	Name	Description
1	24V+	Analog power supply 24V+
2	24V-	Analog power supply 24V-
4		GND
5, 9	V1+, V2+	Voltage input of CH1-CH2
6, 10	FG	Shielding ground
7, 11	I1+, I2+	Current input of CH1-CH2
8, 12	VI1-, VI2-	Common GND of CH1-CH2
3, 13-20	.	NC

Note: an input channel cannot receive both voltage signals and current signals at the same time. If you intend to use a channel for current signal measurement, please short its voltage signal input terminal and current signal input terminal.

1.2 Connecting Into System

Through the extension cable, you can connect IVC1L-2AD to IVC1L series basic module or other extension modules. While through the extension port, you can connect other IVC1L series extension modules to IVC1L-2AD. See Figure 1-3.

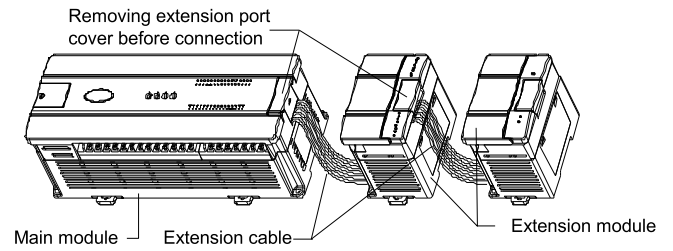

Figure 1-3 Connecting into system

1.3 Wiring

Figure 1-4 shows the wiring of the user port.

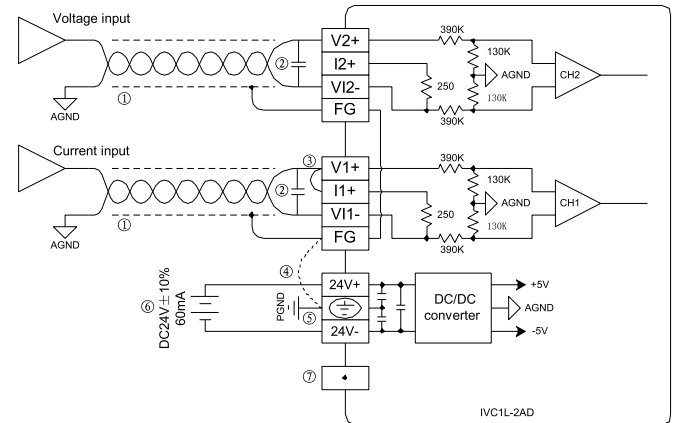

Figure 1-4 Wiring of IVC1L-2AD user port

The circled 1-7 stands for the seven points to be observed during wiring.

1. It is recommended to use shielded twisted pair for the analog input. Route them separate from power cables and any cable that may generate EMI.
2. If input signal fluctuates or there is strong EMI in external wiring, it is advisable to use a smoothing capacitor (0.1μF-0.47μF/25V).
3. If a channel is used for current input, short its voltage input terminal and current input terminal.
4. If strong EMI exists, connect the FG terminal and PG terminal.
5. Properly ground the module's PG terminal.
6. The basic module's 24Vdc auxiliary power or other qualified external power supply can be used as the power source of the module's analog circuit.
7. Do not use the NC terminal of the user port.

2 Indices

2.1 Power Supply

Table 2-1 Power supply

Item	Description
Analog circuit	24Vdc (-15%~20%), maximum allowable ripple voltage 5%, 50mA (from basic module or external power supply)
Digital circuit	5Vdc, 70mA (from basic module)

2.2 Performance

Table 2-2 Performance

Item		Specifications	
Conversion speed		15ms/channel (normal speed), 6ms/channel (high speed)	
Analog input range	Voltage	-10Vdc~+10Vdc, input impedance: 1MΩ	Two channels can be used at the same time, input range can be selected by setting BFM (see Table 2-5)
	Current	-20mA~+20mA, input impedance: 250Ω	
Digital output		Default: -2000~+2000 Setting range: -10000~+10000	
Resolution	Voltage input	Depending on the input range (see Table 2-5)	
	Current input	10μA	
Accuracy		±1% of full range	
Isolation		Between analog circuit and digital circuit: photocoupler. Between analog circuit and input 24Vdc power: DC/DC converter. Between analog channels: none	

2.3 Buffer Memory

IVC1L-2AD exchanges data with the basic module through Buffer Memory (BFM). After IVC1L-2AD is set through the host software, the basic module will write data into IVC1L-2AD BFM to set the state of IVC1L-2AD, and display the data from IVC1L-2AD on the host software interface. See figures 4-2~4-6.

Table 2-3 describes the contents of the BFM of IVC1L-2AD.

Table 2-3 BFM Contents

BFM	Contents	Default	Property
#100	Average value of CH1		R
#101	Average value of CH2		R
#200	Current value of CH1		R
#201	Current value of CH2		R
#300	Error status 0		R
#600	Input mode selection	0x0000	RW
#700	Average sampling times of CH1	8	RW
#701	Average sampling times of CH2	8	RW
#900	CH1-D0	0 (input mode 0)	RW
#901	CH1-A0	0 (input mode 0)	R
#902	CH1-D1	2000 (input mode 0)	RW
#903	CH1-A1	10000 (input mode 0)	R
#904	CH2-D0	0 (input mode 0)	RW
#905	CH2-A0	0 (input mode 0)	R
#906	CH2-D1	2000 (input mode 0)	RW
#907	CH2-A1	10000 (input mode 0)	R
#2000	AD conversion speed switchover	0 (15ms/CH)	RW
#4094	Module software version	0x1000	R
#4095	Module ID	0x1021	R

Explanation:

- CH1 stands for channel 1; CH2 stands for channel 2.
- Property explanation: R means read only. An R element cannot be written. RW means read and write. Reading from a non-existent element will get 0.
- Status information of BFM#300 is shown in Table 2-4.

Table 2-4 Status information of BFM#300

Bit status of BFM#300	ON (1)	OFF (0)
b0: error	b1 or b2 is ON, AD conversion of all channels stopped	No error
b1: channel characteristics setting error	Channel characteristics setting error in BFM	Channel characteristics setting normal
b2: power supply failure	24Vdc power supply failed	Power supply normal

Bit status of BFM#300	ON (1)	OFF (0)
b3: hardware fault	AD converter or other hardware faulty	Hardware normal
b10: digital range error	Digital output after AD conversion less than -2048 or greater than +2047	Digital output value normal
b11: average sampling times setting error	Setting outside normal range (in this case, the previous valid setting will be restored)	Setting within normal range: 1~4096

- BFM#600: input mode selection, used to set the input modes of CH1~CH2. See Figure 2-1 for their correspondence.

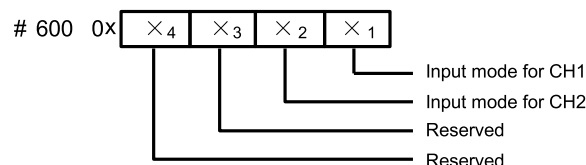

Figure 2-1 Mode setting element vs. channel

Table 2-5 shows the status information of BFM#600.

Table 2-5 BFM#600 information table

Value of X	Status information
0	-10V~10V voltage input mode
1	-5V~5V voltage input or -20mA~20mA current input mode
3	Channel closed

For example, if #600 is written as '0x0001', the setting will be like this:

- Input range of CH1: -5V~5V or -20mA~20mA (note the wiring difference in voltage and current, see 1.3 wiring);
- Input range of CH2: -10V~10V.
- BFM#700~BFM#701: average sampling times setting; setting range: 1~4096. Default: 8 (normal speed); choose 1 if high speed is needed.
- BFM#900~BFM#907: channel characteristics settings, which are set using two-point method. D0 and D1 represent the channel's digital outputs, while A0 and A1, in mV unit, represent the channel's actual inputs. Each channel occupies 4 words. To simplify the setting operation without affecting functions, A0 and A1 are respectively fixed to 0 and the maximum analog value in the present mode. After changing the channel mode (BFM #600), A0 and A1 will change automatically according to the mode. Users cannot change them.
- Note:** If the channel input is current signal (-20mA~20mA), the channel mode should be set to 1. As the channel's internal measurement is based on voltage signal, current signals should be converted into voltage signals (-5V~5V) by the 250Ω resistor at the current input terminal of the channel. A1 in the channel's characteristics setting is still in mV unit, i.e., 5000mV (20mA×250Ω=5000mV).
- BFM#2000: AD conversion speed setting. 0: 15ms/channel (normal speed); 1: 6ms/channel (high speed). Setting BFM#2000 will restore BFM#700~#701 to the default values, which should be noted in programming. If necessary, you can re-set BFM#700~#701 after you change the conversion speed.
- BFM#4094: module software version, displayed automatically as **Module Version** in **IVC1L-2AD Configuration** dialogue box of the host software, as shown in Figure 4-2.
- BFM#4095 is module ID. ID of IVC1L-2AD is 0x1021. The user program in PLC can use this ID to identify the module before transceiving data.

3 Setting Characteristics

The input channel characteristic of IVC1L-2AD is the linear relationship between the channel's analog input A and digital output D. It can be set by the user. Each channel can be considered as the model shown in Figure 3-1. As it is of linear characteristics, the channel characteristics can be defined by just two points: P0 (A0, D0) and P1 (A1, D1), where D0 is the channel's digital output corresponding to analog input A0, and D1 is the channel's digital output corresponding to analog input A1.

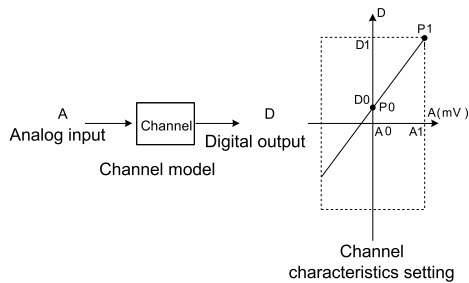

Figure 3-1 Channel characteristics of IVC1L-2AD

To simplify the operation process without affecting functions, A0 and A1 are respectively fixed to 0 and the maximum analog value in the present mode. That is to say, in Figure 3-1, A0 is 0 and A1 is the maximum analog input in the present mode. A0 and A1 will change according to the mode when BFM#600 is changed. Users cannot change their values.

If you just set the channel mode (BFM#600) without changing the D0 and D1 of the corresponding channel, the channel characteristics vs. mode should be as shown in Figure 3-2. The A in Figure 3-2 is default.

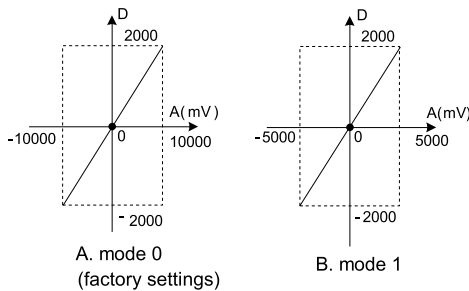
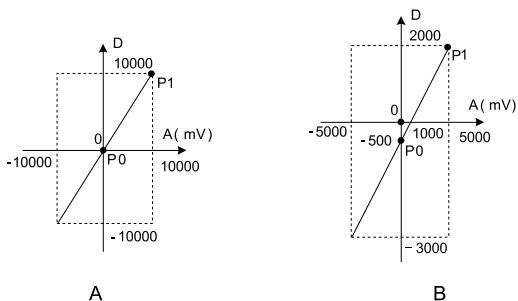

Figure 3-2 Characteristics vs. mode without changing D0 and D1

You can change the channel characteristics by changing D0 and D1. The setting range of D0 and D1 is -10000–10000. If the setting is outside this range, IVC1L-2AD will not accept it, but maintain the original valid setting. Figure 3-3 provides for your reference an example of changing channel characteristics.



Mode 0, D0 = 0, D1 = 10,000
 Analog input 10V outputs 10,000
 Analog input 0V outputs 0
 Analog input -10V outputs -10,000

Mode 1, D0 = -500, D1 = 2000
 Analog input 5V (or 20mA) outputs 2000
 Analog input 1V (or 4mA) outputs 0
 Analog input -5V (or -20mA) outputs -3000

Figure 3-3 Changing input channel characteristics

4 Application Example

4.1 Basic Application

Example: IVC1L-2AD module address is 1 (for the addressing of extension modules, see *IVC1L Series PLC User Manual*). Use CH1 for voltage input (-10V~10V), use CH2 for current input (-20~20mA), set the average sampling times to 4, and use data registers D1 and D2 to receive the average value, as shown in the following figures.

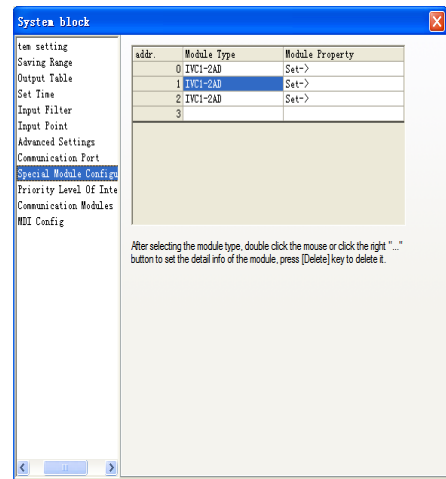

Figure 4-1 Set the module address

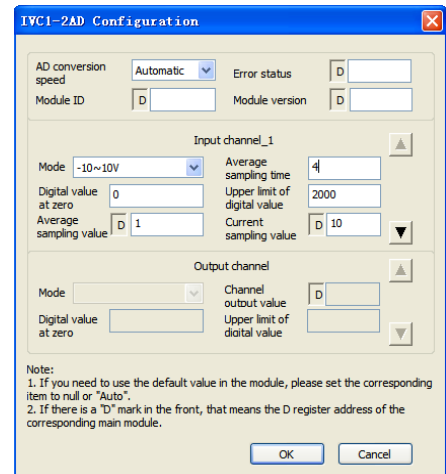

Figure 4-2 CH1 setting interface

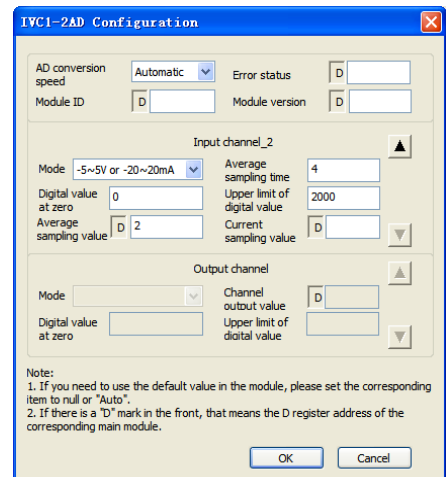

Figure 4-3 CH2 setting interface

4.2 Changing Characteristics

Example: The IVC1L-2AD module address is 3 (for the addressing of extension modules, see *IVC Series PLC User Manual*). Set the average sampling times to 4, set characteristics A and B in Figure 3-3 respectively for CH1 and CH2, and use data registers D1 and D2 to receive the average value, as shown in the following figures.

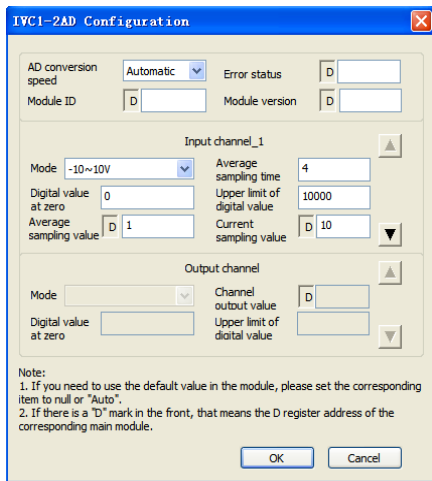

Figure 4-4 Changing CH1 characteristic

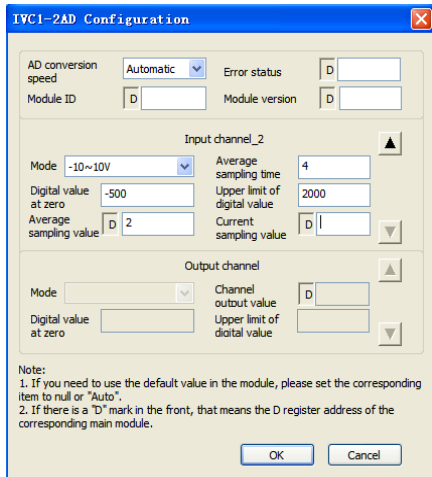

Figure 4-5 Changing CH2 characteristic

Notice

1. The warranty range is confined to the PLC only.
2. **Warranty period is 18 months**, within which period INVT conducts free maintenance and repairing to the PLC that has any fault or damage under the normal operation conditions.
3. **The start time of warranty period is the delivery date of the product**, of which the product SN is the sole basis of judgment. PLC without a product SN shall be regarded as out of warranty.
4. Even within 18 months, maintenance will also be charged in the following situations:
Damages incurred to the PLC due to mis-operations, which are not in compliance with the User Manual;
Damages incurred to the PLC due to fire, flood, abnormal voltage, etc;
Damages incurred to the PLC due to the improper use of PLC functions.
5. The service fee will be charged according to the actual costs. If there is any contract, the contract prevails.
6. Please keep this paper and show this paper to the maintenance unit when the product needs to be repaired.
7. If you have any question, please contact the distributor or our company directly.

Shenzhen INVT Electric Co., Ltd.

Address: INVT Guangming Technology Building, Songbai Road, Matian, Guangming District, Shenzhen, China

Website: www.invt.com

All rights reserved. The contents in this document are subject to change without notice.

5 Operation Inspection

5.1 Routine Inspection

1. Check that the wiring of analog input meets the requirements (see 1.3 wiring).
2. Check that the extension cable of IVC1L-2AD is properly inserted in the extension port.
3. Check that the 5V and 24V power supplies are not overloaded. Note: the digital circuit of IVC1L-2AD is powered by the basic module through the extension cable.
4. Check the application and make sure the operation method and parameter range are correct.
5. Set the IVC1L main module to RUN state.

5.2 Inspection upon Fault

In case of abnormality, check the following items:

- The status of the POWER indicator

ON: The extension cable is properly connected;

OFF: Check the extension cable connection and the basic module.

- The wiring of analog input

- The status of the 24V indicator

ON: 24Vdc power supply normal;

OFF: 24Vdc power supply possibly faulty, or IVC1L-2AD faulty.

- The status of the RUN indicator

Flash quickly: IVC1L-2AD in normal operation;

Flash slowly or OFF: Check the Error Status in IVC1L-2AD Configuration dialogue box through the host software.