



Operation **Manual**

Photovoltaic Grid-connected Inverter



INVT Solar Technology (Shenzhen) Co., Ltd.

Preface

The manual is intended to provide detailed information of product information, installation, application, trouble shooting, precautions and maintenance of iMars series grid-tied solar inverters. The manual does not contain all the information of the photovoltaic system. Please read this manual carefully and follow all safety precautions seriously before any moving, installation, operation and maintenance to ensure correct use and high performance of operation on the inverter.

The use of the iMars series grid-tied solar inverters must comply with local laws and regulations on grid-tied power generation.

The manual needs to be kept well and be available at all times.

All rights reserved. The contents in this document are subject to change without notice.

There may be data deviation because of product improving. Detailed information is in accordant with the final product.

Content

Preface	1
Content	2
1 Safety precautions	4
1.1 Warning marks.....	5
1.2 Safety guidance.....	6
1.2.1 Transport and installation.....	6
1.2.2 Grid-connected operation	7
1.2.3 Maintenance and inspection.....	8
1.2.4 Waste disposal	8
2 Product overview	9
2.1 PV grid-connected power generation system.....	10
2.1.2 Supported grid connection structure	10
2.2 Product appearance	11
2.3 Nameplate	13
2.4 Product model.....	14
2.5 Outline dimension and weight	15
3 Storage	16
4 Installation	17
4.1 Unpacking confirmation	18
4.2 Preparation before installation	19
4.2.1 Installation tool.....	19
4.2.2 Installation site.....	20
4.2.3 Specification of leads	22
4.2.4 Micro breaker	23
4.3 Mechanical installation.....	23
4.3.1 Installation of three-phase inverter	24
4.4 Electrical connection	27
4.4.1 Connection of photovoltaic string	27
4.4.2 Three-phase inverter grid connection	31
5 Running	33

5.1 Inspection before running.....	34
5.2 Inverter grid-connected running.....	34
5.3 Inverter stop	35
5.4 Daily maintenance and inspection	35
5.4.1 Periodic maintenance on the inverter.....	36
5.4.2 Maintenance guidance	37
6 Display operation panel.....	42
6.1 LED state indicator	43
6.2 Operation keypad.....	45
6.3 LCD panel.....	45
6.4 Function operation	46
6.4.1 Monitoring parameter.....	46
6.4.2 Historical records	48
6.4.3 Statistic information	48
6.4.4 Parameter setup.....	48
6.4.5 System information.....	57
6.4.6 Present fault	57
6.4.7 Inverter control.....	57
6.4.8 Mode setup.....	59
6.5 Selection of grid certification standard	59
7 Monitoring communication	61
7.1 Standard communication.....	62
7.2 Optional communication	63
8 Fault isolation	65
9 Contact us	69
10 Appendix.....	70

1 Safety precautions

iMars series grid-tied solar inverters are designed and tested strictly in accordance with relevant international safety standards. As an electrical and electronic device, all relevant safety regulations must be strictly complied during installation, operation, and maintenance. Incorrect use or misuse may result in:













- Injury to the life and personal safety of the operator or other people.
- Damage to the inverter or other property belonging to the operator or other people.

In order to avoid personal injury, damage to the inverter or other devices, please strictly observe the following safety precautions.

This chapter mainly describes various warning symbols in operation manual and provides safety instructions for the installation, operation, maintenance and use of the iMars series grid-tied solar inverters.

1.1 Warning marks





Warning marks inform users of conditions which can cause serious physical injury or death, or damage to the device. They also tell users how to prevent the dangers. The warning marks used in this operation manual are shown below:

Mark	Name	Instruction	Abbreviation
 Danger	Danger	Serious physical injury or even death may occur if not follow relevant requirements.	
 Warning	Warning	Physical injury or damage to the device may occur if not follow relevant requirements.	
 Forbid	Electrostatic sensitive	Damage may occur if relevant requirements are not followed.	
 Hot	High temperature	Do not touch the base of the inverter as it will become hot.	
Note	Note	The procedures taken for ensuring proper operation.	Note
	Grounding	The inverter must be reliably grounded.	
	Discharge	Ensure that DC and AC side circuit breakers have been disconnected and wait at least 5 minutes before wiring and checking.	

Note: Technical personnel who can perform installation, wiring, commissioning, maintenance, troubleshooting and replacement of the iMars series grid-tied solar inverters must meet the following requirements:

- Operators need professional training.
- Operators must read this manual completely and master the related safety precautions.
- Operators need to be familiar with the relevant safety regulations for electrical systems.
- Operators need to be fully familiar with the composition and operating principle of the entire grid-tied photovoltaic power generation system and related standards of the countries/regions in which the project is located.
- Operators must wear personal protective equipment.

1.2 Safety guidance

	<ul style="list-style-type: none"> ● After receiving this product, first confirm the product package is intact. If any question, contact the logistic company or local distributor immediately. ● The installation and operation of PV inverter must be carried out by professional technicians who have received professional trainings and thoroughly familiar with all the contents in this manual and the safety requirements of the electrical system. ● Do not carry out connection/disconnection, unpacking inspection and unit replacement operations on the inverter when power source is applied. Before wiring and inspection, users must confirm the breakers on DC and AC side are disconnected and wait for at least 5 minutes.
	<ul style="list-style-type: none"> ● Ensure there is no strong electromagnetic interference caused by other electronic or electrical devices around the installation site. ● Do not refit the inverter unless authorized. ● All the electrical installation must conform to local and national electrical standards.
	<ul style="list-style-type: none"> ● Do not touch the housing of the inverter or the radiator to avoid scald as they may become hot during operation
	<ul style="list-style-type: none"> ● Ground with proper technics before operation.
	<ul style="list-style-type: none"> ● Do not open the surface cover of the inverter unless authorized. The electronic components inside the inverter are electrostatic sensitive. Do take proper anti-electrostatic measures during authorized operation.

1.2.1 Transport and installation

	<ul style="list-style-type: none"> ● During storage or transport, ensure the inverter package and the chassis is intact, dry and clean. ● The movement and installation of the inverter require at least two persons due to its heavy weight. ● Select proper tools for movement and installation to ensure the inverter can operate normally and avoid physical injury. The installation personnel must take
---	--

	<p>mechanical protective measures such as wearing anti-drop shoes or working clothes to protect physical security.</p> <ul style="list-style-type: none"> ● The inverter must be installed by professional technicians. ● Do not store or install the inverter on flammable and combustible objects; keep the inverter away from flammable and combustible objects. ● Do not install the inverter in places easily accessible to children or other public. ● Remove the metal accessories in hands eg ring or bracelet before device installation and electrical connection to avoid electric shock. ● The solar battery component exposed to the sunlight may generate dangerous voltage. Users must cover the battery component with fully-lightproof materials before electrical connection ● The inverter input voltage cannot exceed the max input voltage, otherwise the inverter may be damaged. ● PV grid-connected inverter is not applicable to the positive or negative ground system of solar battery component. ● Ensure inverter PE is grounded properly, otherwise the inverter cannot run normally. ● Ensure the inverter is installed firmly and electrical wiring is reliable.
--	---

Note: PV grid-connected inverter is only suitable for crystalline silicon-type solar battery component.

1.2.2 Grid-connected operation

	<ul style="list-style-type: none"> ● Permissions by local electric power agency must be obtained and the inverter grid-connected power generation operation must be done by professional technicians. ● All electrical connections must meet the electrical standards of the countries/regions in which the project is located. ● Ensure the inverter is installed firmly and electrical wiring is reliable before operating on the inverter. ● Do not open the housing of the inverter when the inverter is working or powered up.
---	---

1.2.3 Maintenance and inspection

	<ul style="list-style-type: none"> ● The maintenance, inspection and repair of the inverter must be done by well trained and qualified professional technicians. ● Contact distributors and manufactures for repair of the inverter. ● In order to avoid irrelevant personnel from entering the maintenance area during maintenance, temporary warning labels must be placed to warn non-professionals to enter or use fence for isolation. ● Before carrying out any maintenance operations, users must disconnect the breaker on grid side, then disconnect the breaker connected to the PV component and wait for at least 5 minutes until the internal parts of the inverter are fully discharged. ● The internal of the inverter are mostly electrostatic-sensitive circuits and parts, users must follow electrostatic protection protocols and take anti-electrostatic measures. ● Do not use components provided by other companies when repairing the inverter. ● The inverter can be started again for grid-connected power generation only after confirming there is no fault that may impact the safety performance of the inverter. ● Do not get close to or touch the grid or any metal conductive parts in the PV power generation system during operation, otherwise electric shock or fire may occur. Take note of any safety marks and instructions similar to “Danger, electric shock risk”.
---	---

1.2.4 Waste disposal

	<ul style="list-style-type: none"> ● Do not dispose of the inverter together with household waste. The user has the responsibility and obligation to send it to the designated organization for recycling and disposal.
---	--

2 Product overview

This chapter mainly describes the appearance, package accessories, nameplate and technical parameters of the grid-connected inverter.

2.1 PV grid-connected power generation system

PV grid-connected power generation system is comprised of solar battery component, grid-connected inverter, power energy gauging device and public grid.

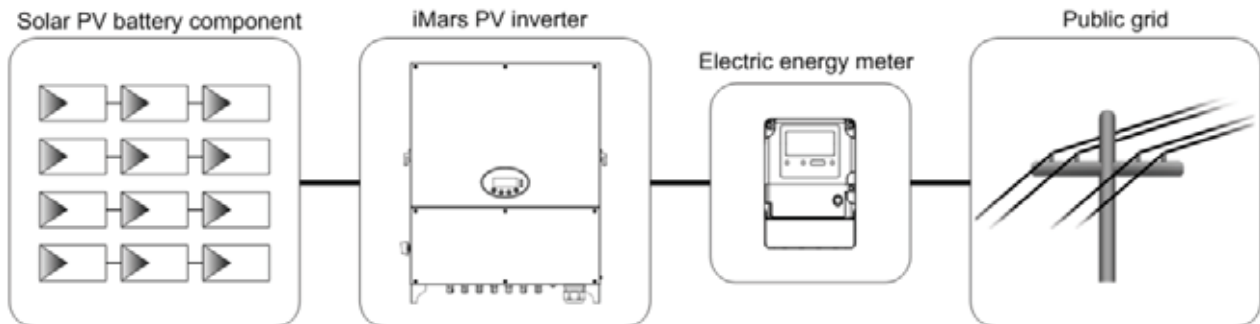

Fig 2.1 Application of PV grid-connected inverter

The PV grid-connected inverter is the core part of solar PV grid-connected power generation system. The sunlight can be converted to DC energy through PV component, then it is converted to the sine AC current which has the same frequency and phase position with the public grid via photovoltaic grid-connected inverter, and feedback such energy to the grid.



- It is recommended that the PV array to be installed conforms to IEC 61730 class A standards.

2.1.2 Supported grid connection structure

iMars series grid-tied solar inverters support TN-S, TN-C, TN-C-S , TT and IT grid connection.

When applied to the TT connection, the N-to-PE voltage should be less than 30V.

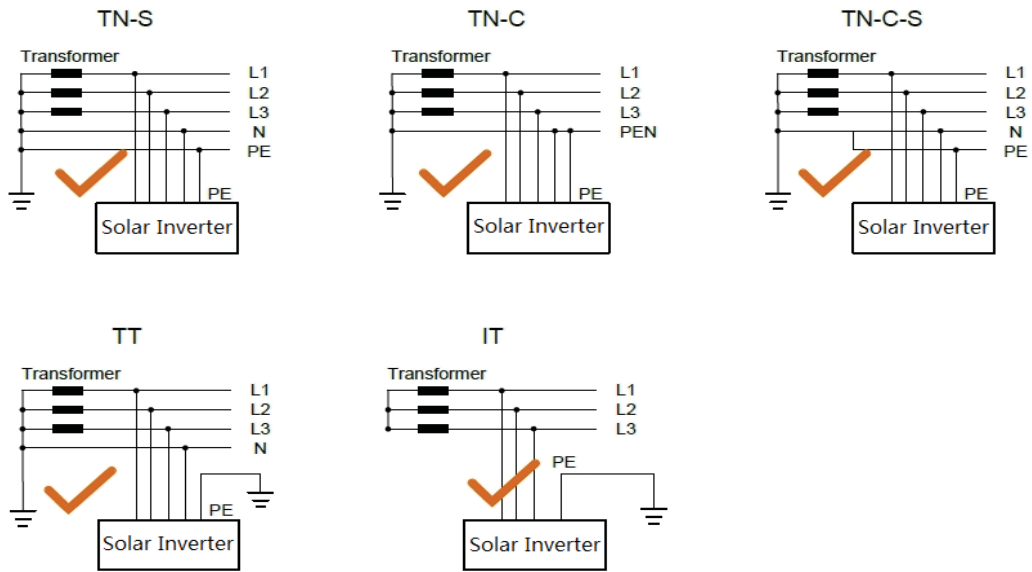

Figure 2.2 Type of grid

2.2 Product appearance

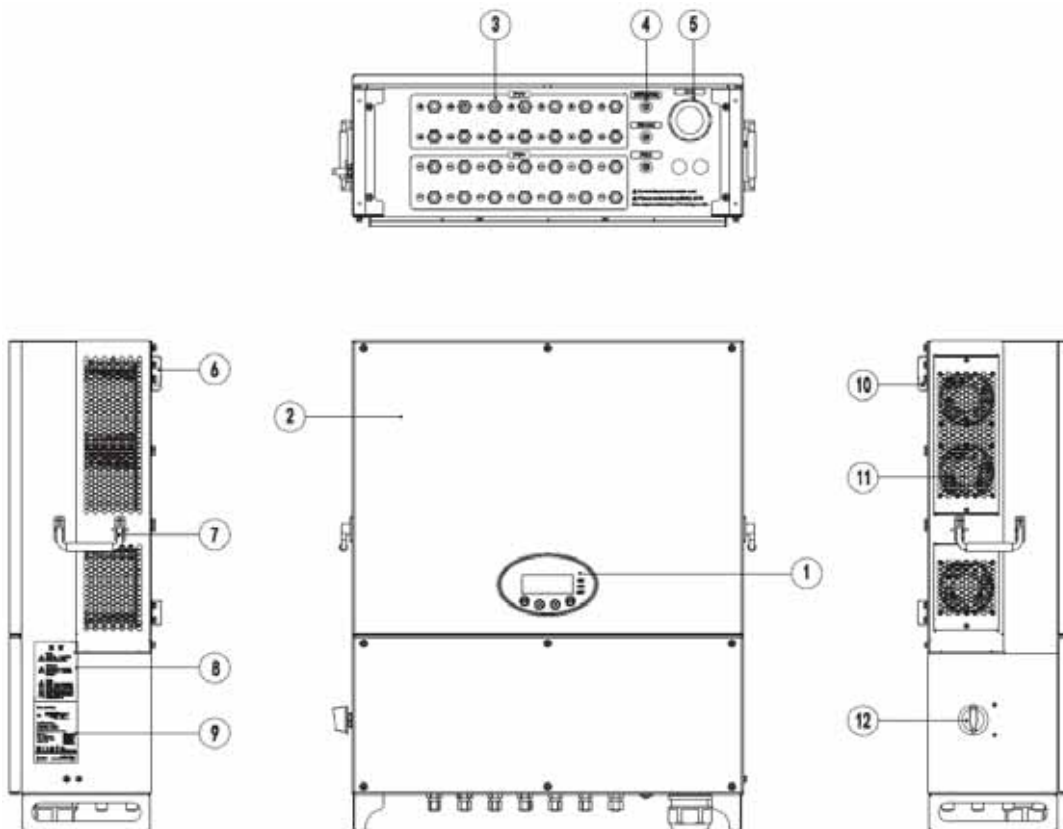

Fig 2.3 Appearance of 40-70kW three-phase PV inverter

Table 2-1 Instruction for key cosmetic parts of three-phase PV inverter

No	Name	Instruction
1	Display operation panel	LED state indicator
2	Surface cover	
3	DC input interface	Inverter DC input port, connect to PV array
4	Communication interface	RS485 communication interface and its extension port EXT
5	AC terminal	Inverter AC output port, connect to public grid
6	Hanging slot	The docking port between inverter master and installation bracket
7	Handle	The force bearing point when moving the inverter
8	Safety precautions	
9	Nameplate	Indicate the rated inverter parameters
10	Anti-theft screw hole	Used to fix the inverter to the installation bracket
11	Fan installation component	Air inlet port, used to fix the fan
12	DC switch	Switch on or switch off DC input

2.3 Nameplate

Figure 2.4 shows the inverter nameplate.

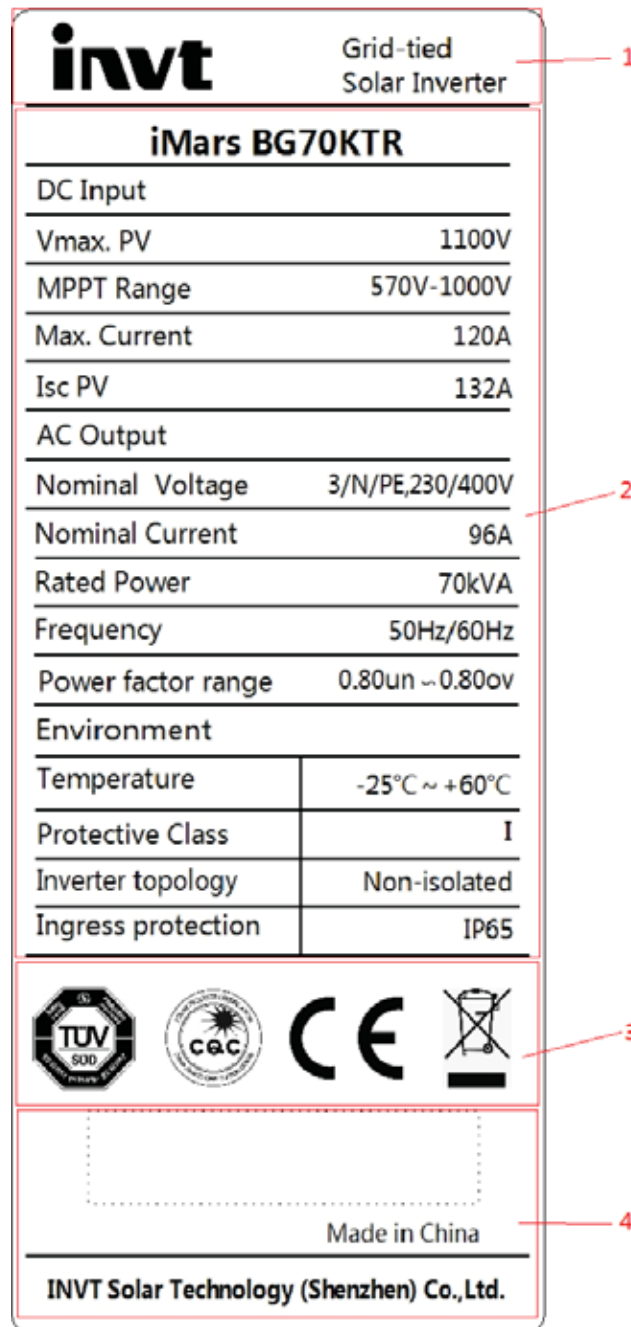





Figure 2.4 Inverter nameplate

- (1) Trademark and product type
- (2) Model and important technical parameters
- (3) Certification system of the inverter confirming
- (4) Serial number, company name and country of origin

Icons	Instruction
	<ul style="list-style-type: none"> TUV certification mark. The inverter is certified by TUV.
	<ul style="list-style-type: none"> CE certification mark. The inverter complies with the CE directive.
	<ul style="list-style-type: none"> CQC certification mark. The inverter passed CQC certification.
	<ul style="list-style-type: none"> EU WEEE mark. The inverter cannot be disposed of as domestic waste.

2.4 Product model

Table 2-3 Models of three-phase PV grid-connected inverter

Product name	Model	Rated output power (W)
three-phase(L1, L2, L3, N, PE)		
three-phase photovoltaic grid-connected inverter	40kW	40kW
three -phase photovoltaic grid-connected inverter	50kW	50kW
three -phase photovoltaic grid-connected inverter	60kW	60kW
three -phase photovoltaic grid-connected inverter	70kW	66kW
three -phase photovoltaic grid-connected inverter	50KW -HV	50KW
three -phase photovoltaic grid-connected inverter	70KW -HV	70KW

Note: Technical parameters of iMars series inverter refers to appendix

2.5 Outline dimension and weight

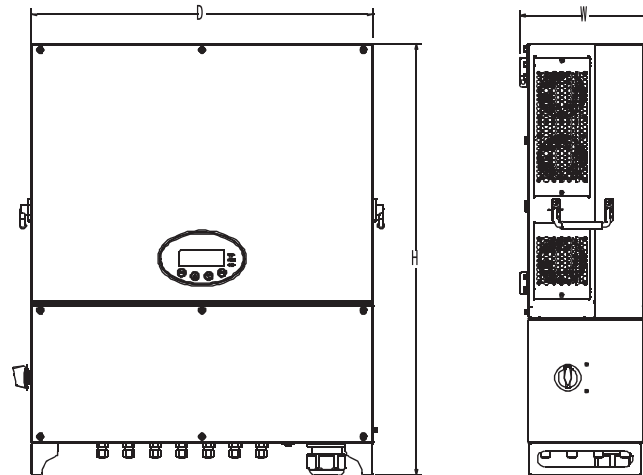

Fig 2.6 Outline dimension of the inverter

Table 2-4 Dimension and net weight of the inverter

Model	Height(mm)	Width(mm)	Depth(mm)	Net weight(kg)
40-70kW	810	645	235	52
70kW -HV	810	645	235	52
50kW-HV	660	645	255	55

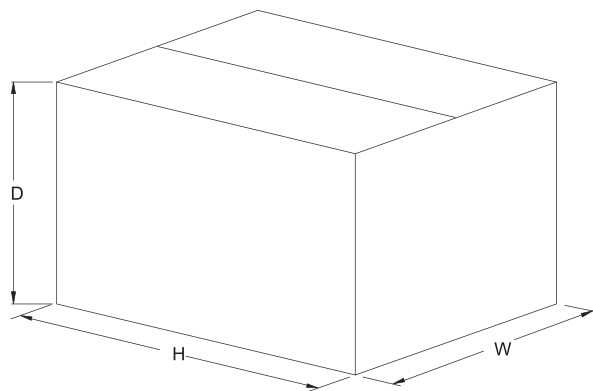

Fig 2.6 Dimension of paper package

Table 2-5 Package dimension and gross weight

Model	Height (mm)	Width (mm)	Depth (mm)	Weight (kg)	Package material
40-70kW	990	810	420	62	K3K
70kW -HV	990	810	420	62	K3K
50kW-HV	835	815	410	60	K2K

3 Storage

If the inverter is not put into use immediately, the storage of inverter should meet the following requirements:

- Do not remove the outer packing.
- The inverter needs to be stored in a clean and dry place, and prevent the erosion of dust and water vapor.
- The storage temperature should be kept at $-40^{\circ}\text{C}\sim+70^{\circ}\text{C}$, and the relative humidity should be kept at 5%RH~95%RH.
- The stacking of inverters is recommended to be placed according to the number of stacking layers in the original shipment. Place the inverter carefully during stacking to avoid personal injury or equipment damage caused by the falling of equipment.
- Keep away from chemically corrosive substances that may corrode the inverter.
- Periodic inspections are required. If damages are found by worms and rats, or packaging are found to be damaged, the packaging materials must be replaced in time.
- After long-term storage, inverters need to be inspected and tested by qualified personnel before put into use.

4 Installation

This chapter describes how to install the inverter and connect it to the grid-tied solar system (including the connection between solar modules, public grid and inverter).

Read this chapter carefully and ensure all installation requirements are met before installation. Only qualified electricians are allowed to install the inverter.

4.1 Unpacking confirmation

The inverter has been thoroughly tested and rigorously checked before delivery, but damage may still occur during transportation. Before unpacking, check carefully whether the product information in the order is consistent with that on the nameplate of the package box and whether the product package is intact. If any damage is detected, please contact the shipping company or the supplier directly. Please also provide photos of the damage to get our fastest and best service.

Store the idled inverter in its original package and take anti-moisture and anti-dust measures.

After taking the inverter out of the box, check the following items:

- (1) Confirm the main body of the inverter is intact and free from any damage;
- (2) Confirm there is operation manual, interface accessories and installation accessories inside the package box;
- (3) Confirm the deliverables inside the package box are intact and complete;
- (4) Check whether the product information in the order is consistent with that on the inverter nameplate;
- (5) The standard delivery list is shown below.

Standard deliverables of three-phase inverter:

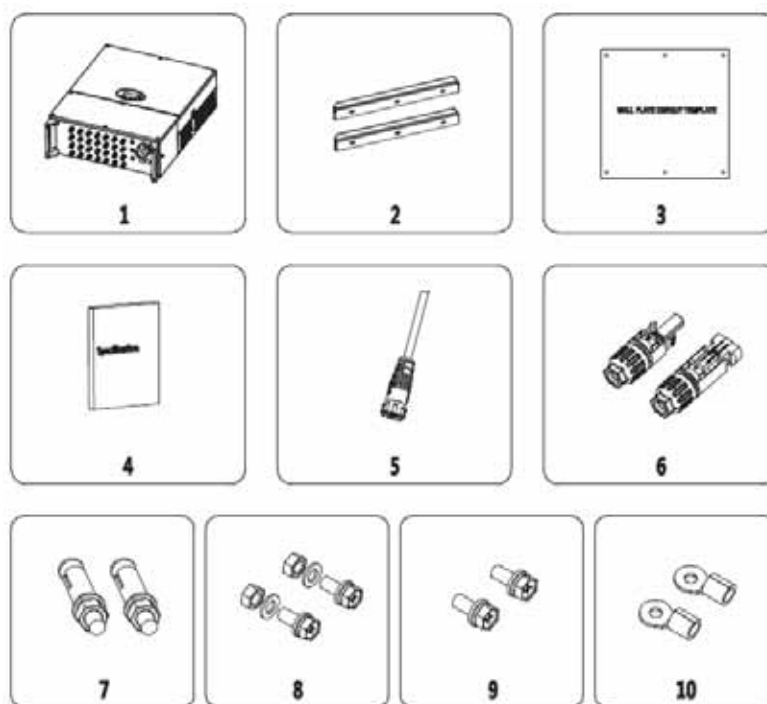

Fig 4.1 Deliverables of 40–70kW three-phase inverter

Table 4-1 Deliverables of three-phase inverter

No	Name	Quantity
1	Inverter	1
2	Installation bracket	1
3	Punch positioning plate	1
4	User manual	6
5	Communication connector	1
6	DC connector	40KW:8pairs,50KW:10 pairs, 60/70KW:14 pairs
7	Expansion bolt M8*60	6
8	Hex combination bolt M8*20	6
9	Combination bolt M5*20	2
10	AC ring terminal	5

Check above-mentioned items carefully and if any question, contact the supplier immediately.

4.2 Preparation before installation

4.2.1 Installation tool

Table 4-2 List of installation tool

No	Installation tool	Purpose
1	Marker	Indicate the installation hole
2	Electric drill	Drill holes in the bracket or on the wall
3	Hammer	Knock on the expansion bolt
4	Adjustable wrench	Fix the installation bracket
5	Inner hex screwdriver	Tighten the anti-theft screw and disassemble AC junction box
6	“Slotted” or “cross-head” screwdriver	AC wiring
7	Megameter	Measure the insulation performance and grounding impedance
8	Multimeter	Check the circuit and measure AC/DC voltage
9	Electric soldering iron	Solder the communication cable
10	Wire crimper	Crimp DC terminal
11	Hydraulic clamp	Crimp ring terminal for AC wiring

4.2.2 Installation site

Select installation site according to below requirements:

- (1) The height of the installation position should ensure that the line of sight is on the same level as the LCD for viewing the parameters inverter conveniently.

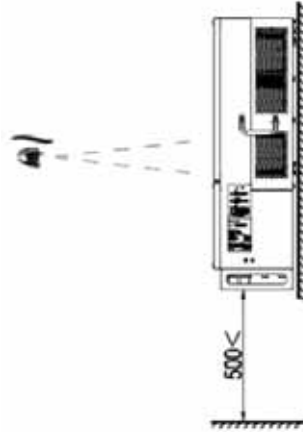

Figure 4.2 Optimal mounting height

- (2) The installation site must be well ventilated and away from raindrops or direct sunlight.
- (3) There must be enough pre-reserved space around the installation site for convenient disassemble of the inverter and air convection, as shown in Fig 4.3.

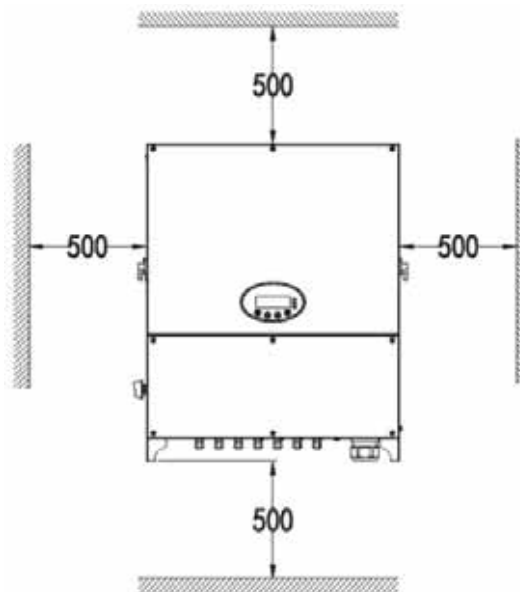

Fig 4.3 Installation spacing

When install more than one inverter, it is necessary to reserve a certain space between the inverters. The left and right spacing is shown as Figure 4.4, and the upper and lower sides of the inverter should have sufficient space to ensure good heat dissipation.

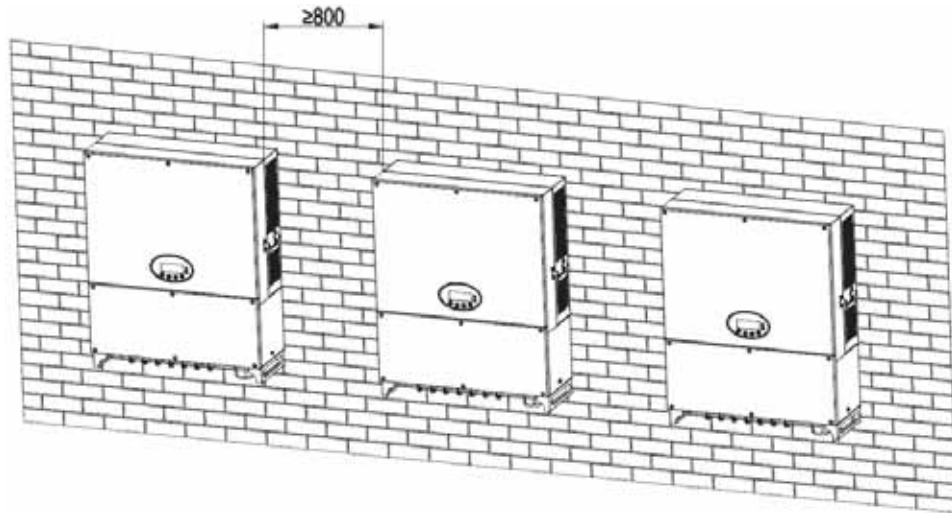

Figure 4.4 Side-by-side installation space requirements

- (4) The ambient temperature of installation should be $-25^{\circ}\text{C}\sim 60^{\circ}\text{C}$
- (5) The installation site should be away from electronic devices which can generate strong electromagnetic interference
- (6) The inverter should be installed on firm and solid surface eg wall surface and metal bracket
- (7) The installation surface should be vertical to the horizontal line, as shown in Figure 4.5

Install the inverter vertically or backward $\leq 15^{\circ}$ to facilitate heat dissipation.

Do not tilt the inverter forward, horizontal, upside down, over- backward, and roll when install the inverter.

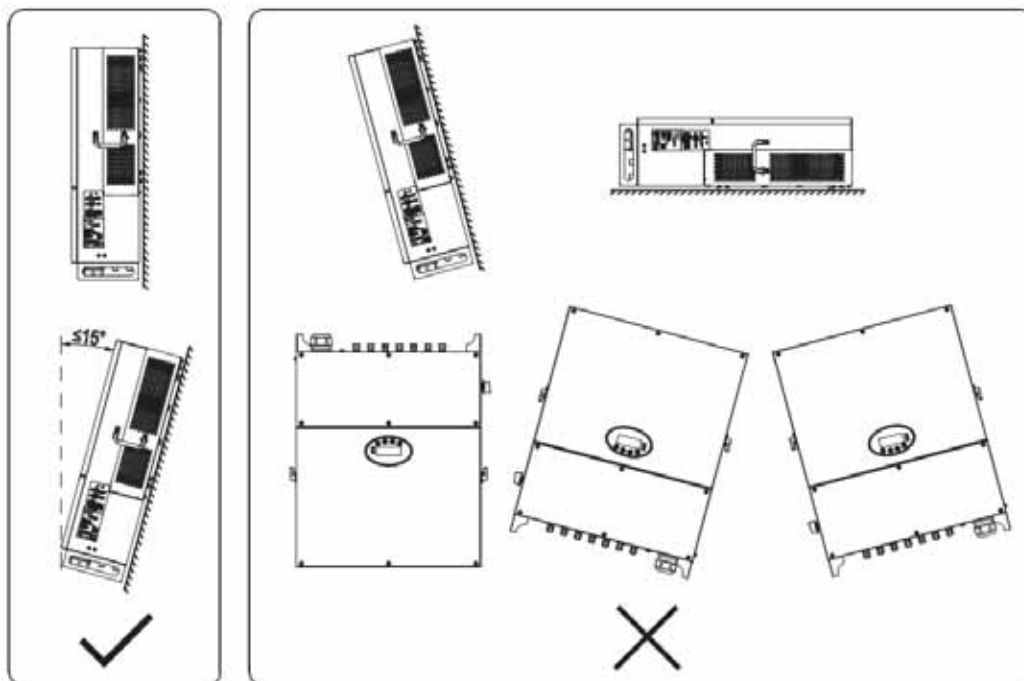

Fig 4.5 Installation position of the inverter

(8) The installation should ensure that the inverter is reliably grounded, and the material of grounded metal conductor should be consistent with the metal material reserved for the grounding of the inverter.



- Do not open the surface cover of the inverter or replace any part as incomplete inverter may cause electric shock and damage the device during operation.

4.2.3 Specification of leads

In order to regulate and compatible with the inverter AC/DC connector or terminal block specifications, below requirements on the AC/DC leads connected to corresponding inverter models should be fulfilled:

Table 4-3 Recommended lead specification

Inverter model	DC side		AC side			
	Min cross-section mm ² (length≤50m)	Min cross section areamm ² (Length>50m)	Min cross section areamm ² (Length≤50m)		Recommended terminals	
			L	N/PE	L	PE
40kW	4	6	25	16	GTNR25-6	GTNR16-5
50kW	4	6	25	16	GTNR25-6	GTNR16-5
60kW	4	6	35	25	GTNR35-6	GTNR25-5
70kW	4	6	35	25	GTNR35-6	GTNR25-5

4.2.4 Micro breaker

In order to ensure safe operation of the inverter and circuits, it is recommended to configure corresponding micro breaker or fuse on the DC input end and AC output end of the inverter. Table 4-4 is the requirements recommended for micro breaker:

Table 4-4 Specification of micro breaker

Inverter model	DC side	AC side
	Recommended breaker specification	Recommended breaker specification
40kW	DC1000V, C100A, 2P	AC400V, C80A, 4P
50kW	DC1000V, C100A, 2P	AC400V, C100A, 4P
60kW	DC1000V, C150A, 2P	AC400V, C150A, 4P
70kW	DC1000V, C150A, 2P	AC400V, C150A, 4P

4.3 Mechanical installation

The material for fixing the inverter and the installation mode vary with the different installation sites. It is recommended to install the inverter vertically to the firm wall or metal bracket. Here we take wall installation as an example to introduce the installation matters of the inverter. Note that the mechanical installation modes for single-phase and three-phase inverter are slightly different as they carry differing outline structures.

As shown in the fig 4.5, the overall installation of the inverter should be vertical to the horizontal surface.

4.3.1 Installation of three-phase inverter

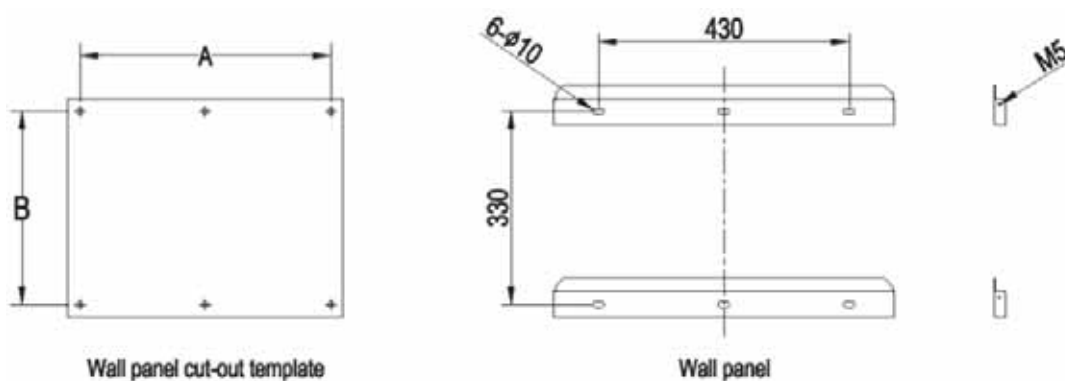

Fig 4.6 Installation bracket of 60kW three-phase inverter

Table 4-5 Dimension of three-phase inverter installation bracket

Inverter model	Spacing of installation hole	
	A(mm)	B(mm)
40-70kW	430	330
70kW-HV	430	330
50kW-HV	400	400

The procedures for installing 3-phase PV inverter are listed below:

- (1) Use the punch positioning plate in the packaging box to determine the punch position. As shown in Figure 4.7. Level the holes with a level ruler and mark it with a marking pen.

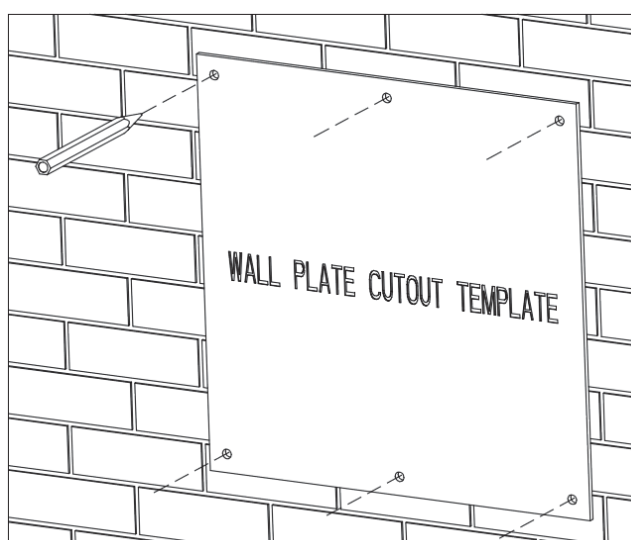

Figure 4.7 Determine the punch position

(2) Drill 6 installation holes on the wall with electric drill. As shown in Figure 4.8

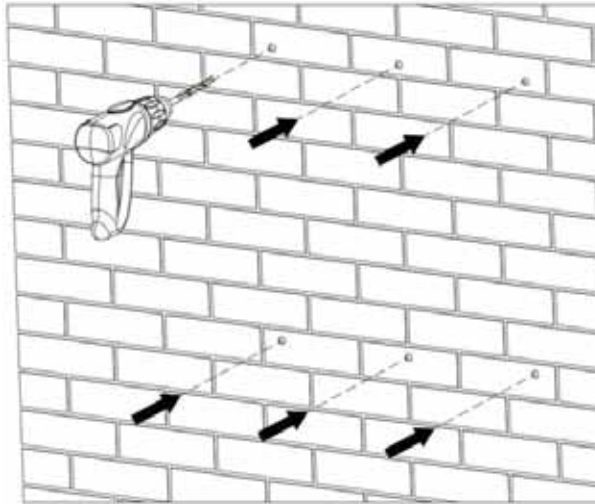

Figure 4.8 Drilling

(3) Fix the expansion bolts to the 4/6 installation holes with hammer, as shown in Figure 4.9.

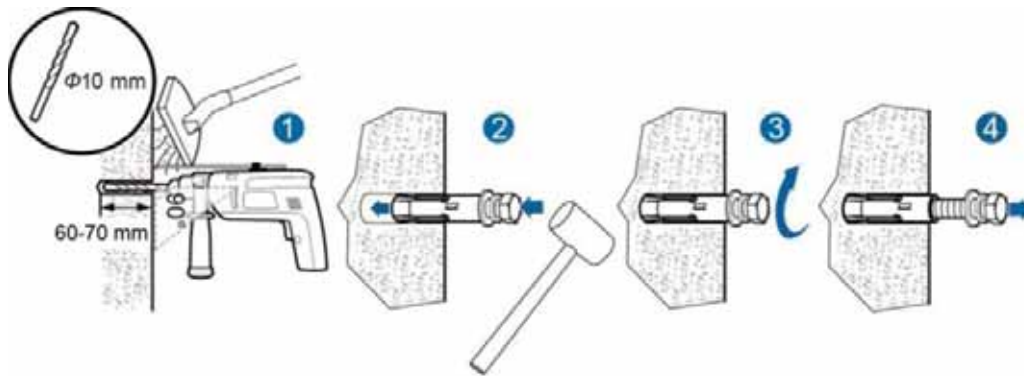

Figure 4.9 Install expansion bolts

(4) Fix the installation bracket onto the expansion bolts and ensure the installation is firm enough (tightening torque is $13\text{N}\cdot\text{m}$). As shown in Figure 4.10.

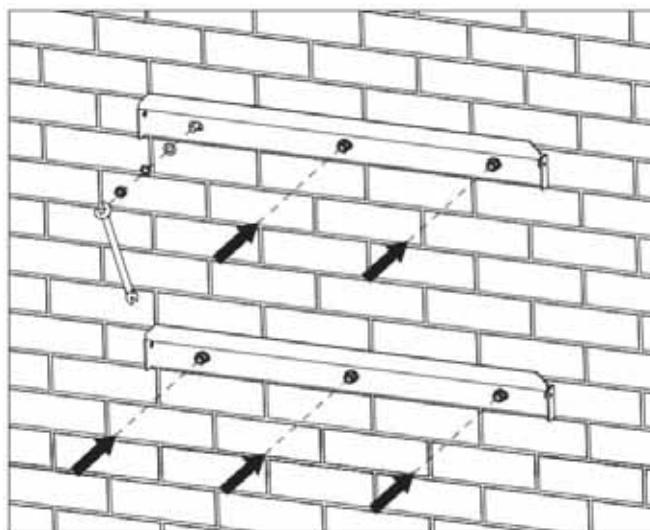

Figure 4.10 Fix the installation bracket

- (5) Hang the inverter onto the installation bracket and ensure the installation is firm enough.
As shown in Figure 4.11.

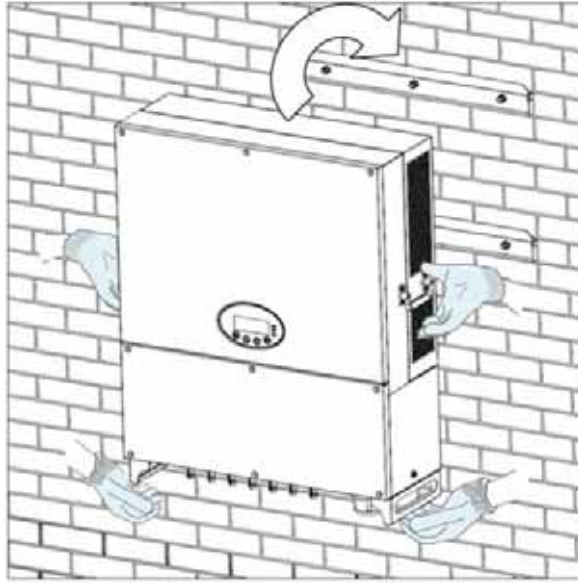

Figure 4.11 Installation of inverter

- (6) Ensure the inverter is installed properly and tighten the M5X20 bolts into the screw holes on the left and right side of inverter(tightening torque is $3\text{N}\cdot\text{m}$). As shown in Figure 4.12.

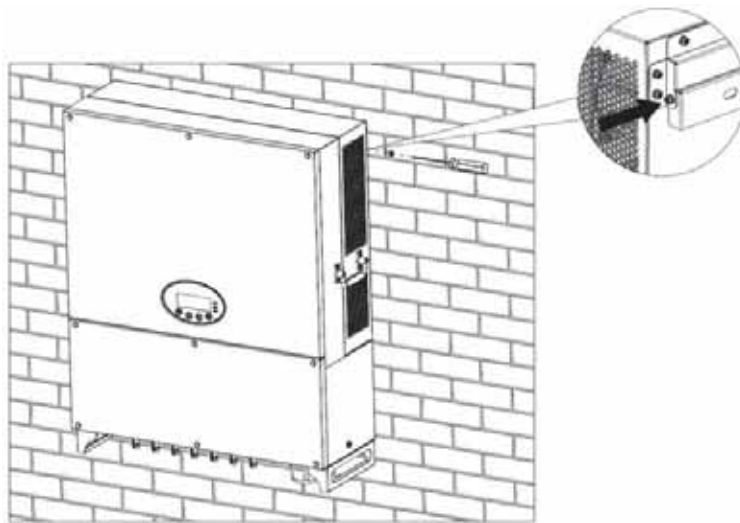

Figure4.12 Installation of M5X20 bolts

4.4 Electrical connection

This section presents the detailed contents and safety precautions related to electrical connection. Fig 4.13 is the connection diagram for PV grid-connected system.

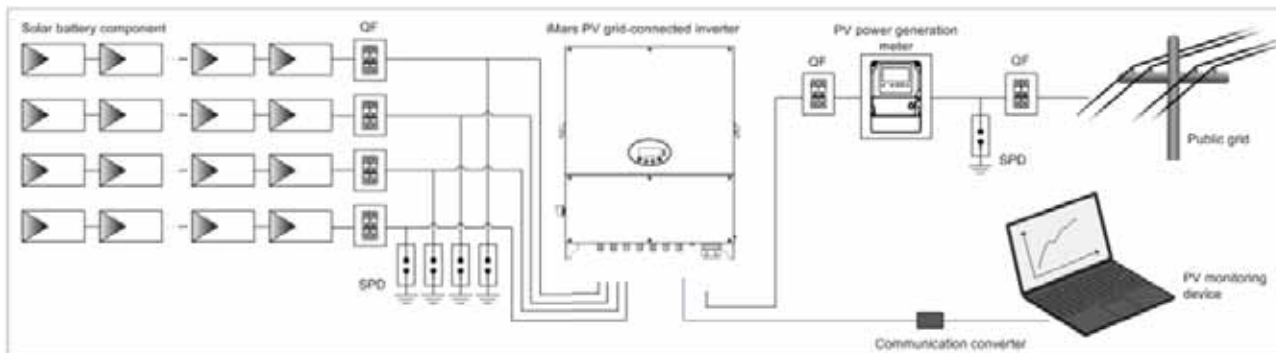



Fig 4.13 Connection diagram for PV grid-connected system

	<ul style="list-style-type: none"> ● Electrical connection must be carried out by professional technicians as wrong operation may cause damage to the device, physical injuries or even death during system operation. ● All the electrical installation must conform to the national and regulations concerning electrical safety regulations. ● Ensure all the cables are installed firmly according to the specified safety requirements and free from any damage. ● It is not allowed to close the AC and DC breakers before the inverter is electrically connected.
<p>Note</p>	<ul style="list-style-type: none"> ● Read this section carefully and operate strictly according to the requirements. ● Note the rated voltage and current value specified in the manual as they cannot be exceeded.

4.4.1 Connection of photovoltaic string

Plan 1: Use PG head

PV+ wiring diagram

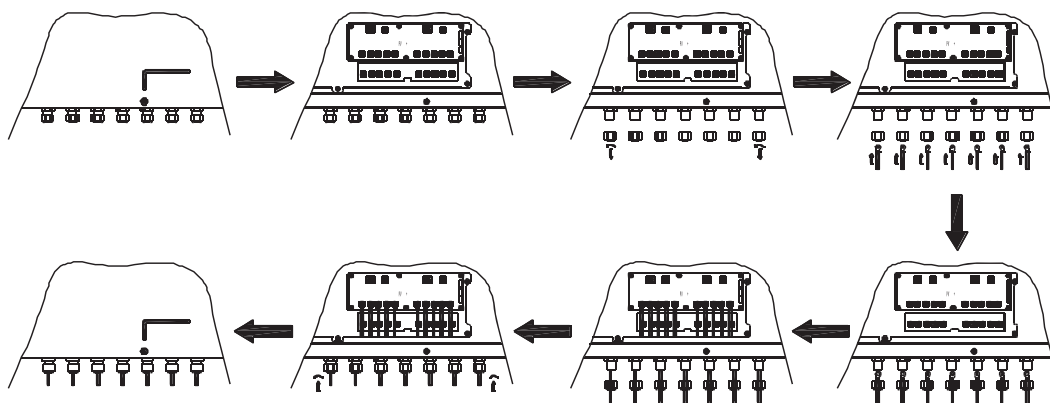

PV- wiring diagram

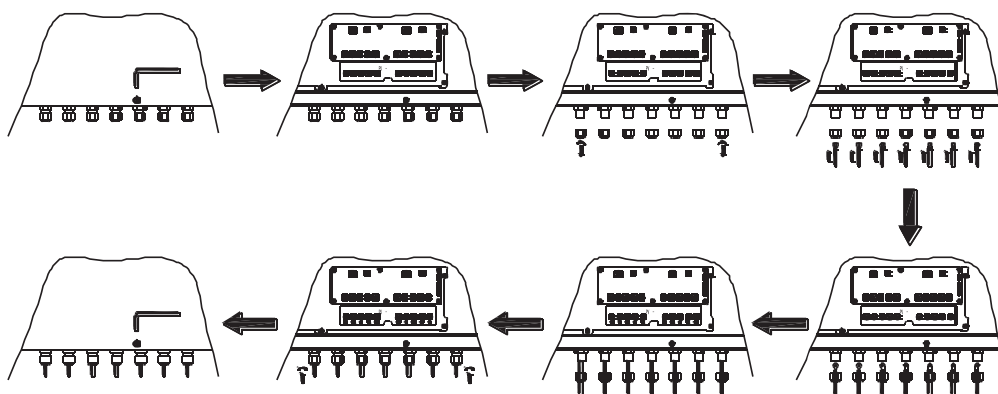



Fig 4.14 Connection of DC connector and PV string

The procedures for connecting three-phase PV inverter DC input to the PV string are shown below:

(1) Before connecting the inverter to PV string, ensure proper measures against lightning and short circuit have been taken;

	<ul style="list-style-type: none"> ● three-phase PV inverter can be connected only after protection measures which conform to local electrical regulations are taken and the technical parameters in this manual are fulfilled.
---	--

(2) Open the wiring bin of the inverter, make the anode and cathode of the PV string whose terminals have been well crimped go through the water-proof PG head, and fix the terminals to corresponding position, and ensure the conductor of the lead is unexposed and crimped firmly;

(3) Before connecting DC connector to inverter, use a multimeter to measure the voltage of the DC input string, verify the polarity of the DC input cable, and ensure that the voltage of each string is within the allowable range of the inverter, as shown in Figure 4.16.

	<ul style="list-style-type: none"> The PV string connected to 3-phase PV inverter DC input must adopt the DC connector configured especially for the inverter, do not use other connection devices without authorization from our company, otherwise damage to the device, unstable operation or fire may occur and our company will not undertake quality assurance or assume any direct or joint liability thereof.
---	--

Plan 2: Use straightly-inserted terminal

Step 1: Connect the outlet of PV board to the terminal delivered along with the machine

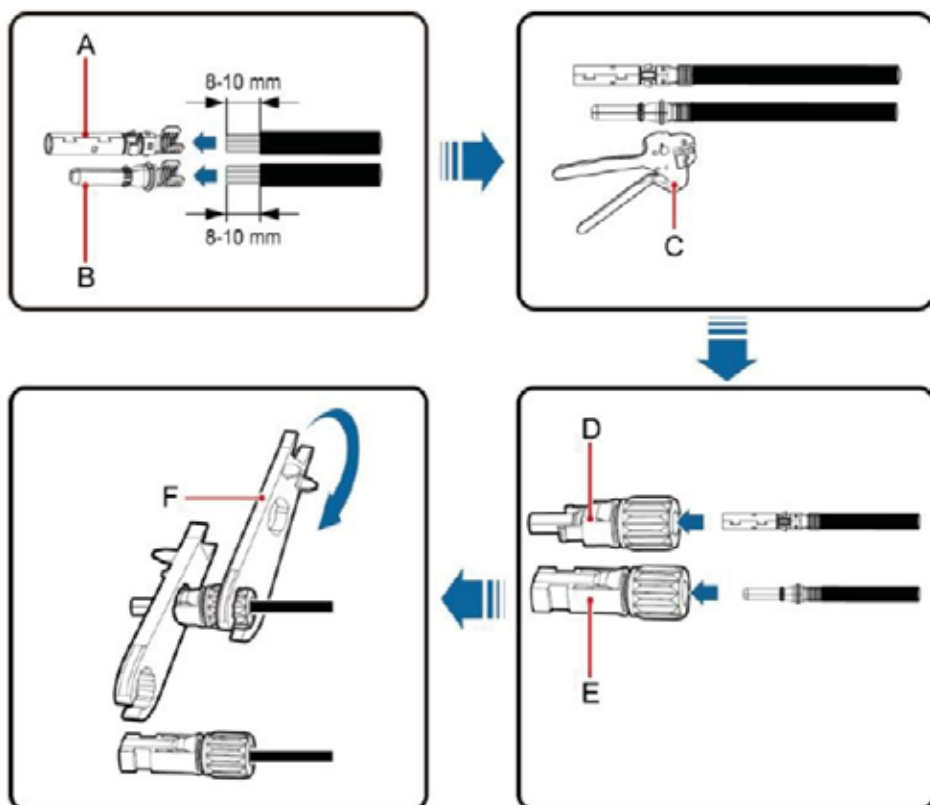



Figure 4.15 Connection of MC4 DC connector and PV string

- (1) Lighting, short-circuit and other protection measures which meet the local electrical safety laws and regulations are needed before the connect PV strings to inverter

	<ul style="list-style-type: none"> PV strings can be connected to inverter only after protection measures which conform to local electrical regulations are taken and the technical parameters in this manual are fulfilled.
---	---

- (2) Connect the output cables of solar modules to the DC connector as figure 4.15 shows. Loosen the nut of the connector and remove the isolation layer of the DC cable for about 15mm. Insert it into the connector and press until you hear the lock sound. Finally tighten the nut to a torque of 2.5-3 Nm. The wiring of the negative pole is the same as that of the positive pole. Ensure the poles of solar modules are well connected with the connectors;
- (3) After the DC connector is connected, use a multimeter to measure the voltage of the DC input string, verify the polarity of the DC input cable, and ensure that the voltage of each string is within the allowable range of the inverter, as shown in Figure 4.16.

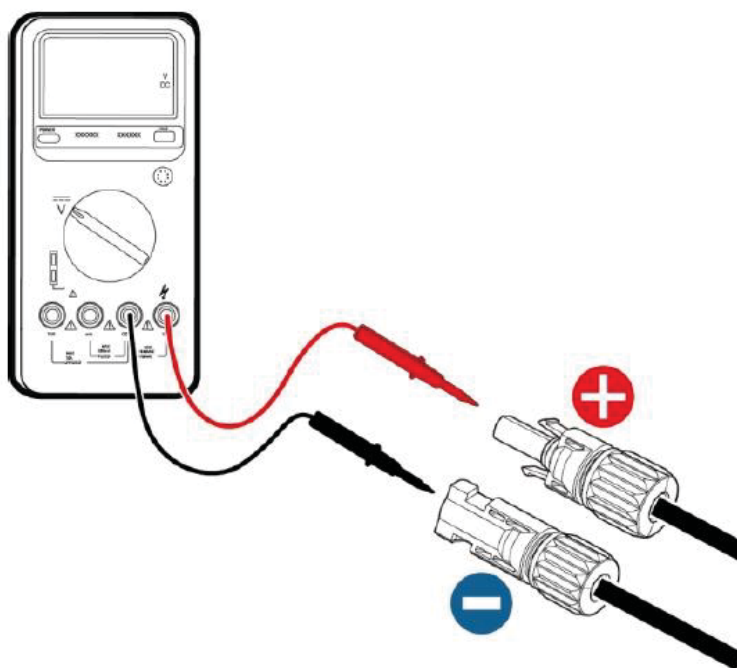



Figure 4.16 DC input voltage measuring

	<ul style="list-style-type: none"> The PV string connected to iMars series inverter must adopt the DC connector configured especially for the inverter, do not use other connection devices without authorization from our company, otherwise damage to the device, unstable operation or fire may occur and our company will not undertake quality assurance or assume any direct or joint liability thereof.
---	---

Step 2: After connecting the terminal, insert it into the MC4 terminal of the machine

- (1) Connect PV string to the inverter and ensure tightly-fastened, as shown in Figure 4.17
- (2) When removing the DC connector from the inverter, insert the head of the straight screwdriver into the raised hole in the middle of the connector, and force the movable end of the connector to exit.

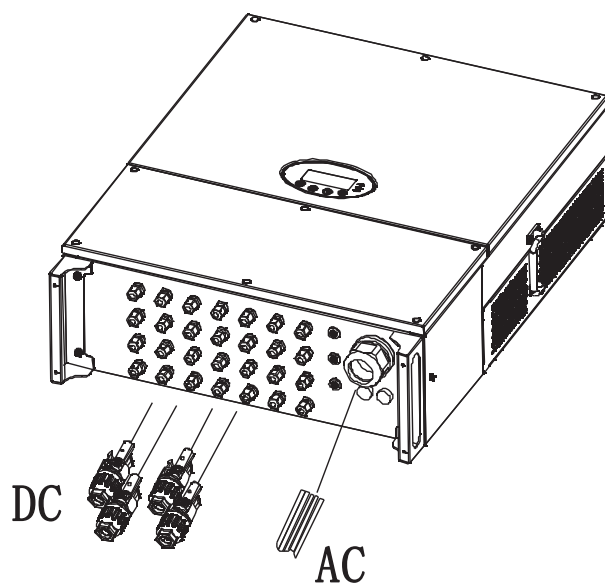

Figure 4.17 Connect PV string to inverter

4.4.2 Three-phase inverter grid connection

4.4.2.1 Terminal block grid connection

First, take off the protection cover of the AC connector and the bottom panel of the machine, then connect the five leads L1, L2, L3, N (optional) and PE of three-phase public grid to the AC connector interface, and ensure the conductor of the lead is unexposed and crimped firmly; then connect the connection port of AC connector to the AC connection port of the inverter, and ensure the leads of AC cable correspond to the connection ports of the connector and are tightened firmly.

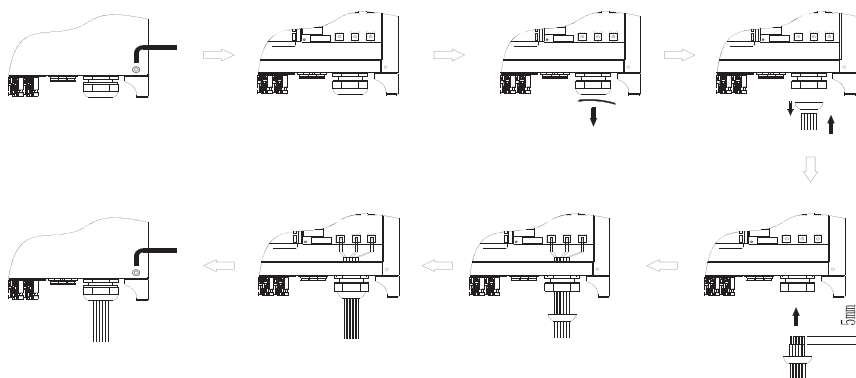
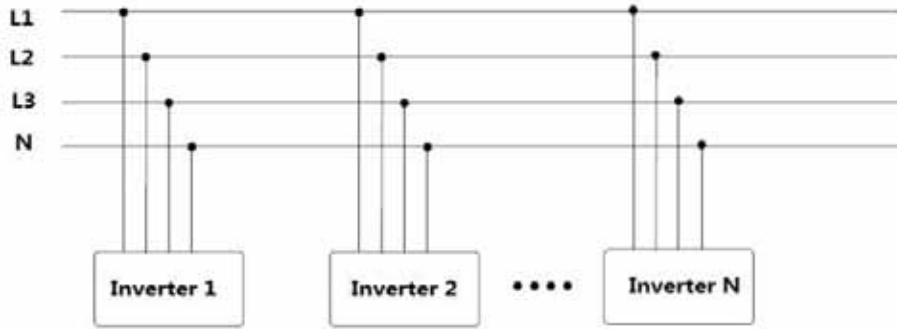

Fig 4.18 three-phase inverter 40–70kW grid connection

4.4.2.2 Parallel connection requirements of multiple inverters

Connect multiple inverters to low-voltage three-phase grid directly. If the total capacity of the inverter exceeds 1.6MVA, contact our after-sale service staff.



Connect multiple inverters to the low-voltage side of the medium-voltage transformer and connect high-voltage side to the medium-voltage grid directly. If total capacity of the inverter exceeds 1.6MVA, contact our after-sale service staff. Meanwhile, the transformer should fulfill total output requirement of the inverter and has neutral point or externally-connected neutral conductor.

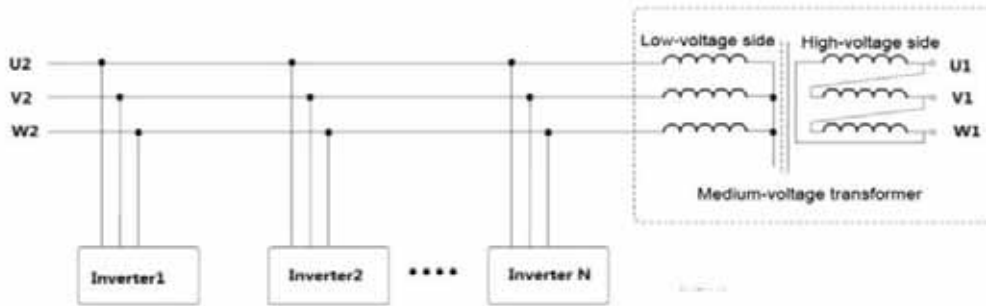

- It is recommended to use the transformer whose short-circuit impedance is no more than 7%

5 Running

This chapter mainly introduces operations related to the usage of PV inverter, which involves inspection before running, grid-connected running, inverter stop and daily maintenance precautions.

5.1 Inspection before running

The following items must be checked strictly before running the PV grid-connected inverter (including but not limited to the following items):

- (1) Confirm the installation site of the inverter fulfill requirements of section 4.2.2 to ensure convenient installation, disassemble, operation and inspection on the inverter;
- (2) Confirm the mechanical installation of the inverter fulfills requirements of section 4.3;
- (3) Confirm the electrical connection of the inverter fulfills the requirements of section 4.4;
- (4) Confirm all the switches are in “OFF” state;
- (5) Confirm the open-circuit voltage of PV component conforms to the parameter requirements of inverter DC side in appendix;
- (6) Confirm the electrical safety marks on the installation site is clear enough.



- In order to ensure a safe, normal and stable operation of the PV power generation system, all the newly installed, renovated and repaired PV grid-connected power generation system and its grid-connected inverter must undergo inspection before running.

5.2 Inverter grid-connected running

Start the inverter according to below steps to achieve grid-connected operation of the inverter:

Note

- ***It is a must to select the country to set grid-connected standard during the initial operation of the inverter, see details at section 6.5.***
- Keep the power-on state of the inverter for at least 30 minutes, and complete the charging of built-in clock battery of the inverter to ensure the clock can run normally!

- (1) Confirm the requirements in section 5.1 are fulfilled;
- (2) Close the breaker on inverter public grid AC side;
- (3) Close the integrated DC switch of the inverter;
- (4) Close the circuit switch on PV string DC input side;
- (5) Observe the LED indicator state of the inverter and the information displayed by LCD.
Refer to chapter 6 for LED state indicator and LCD display information.

● Run green indicator flickers, other indicators are off: inverter is powered on and under self-inspection, wait for enough light to fulfill grid-connected condition;

● Run green indicator is on and other indicators are off: inverter self-inspection has passed and grid-connected power generation is on – pilot run succeeded.

“Warn” or “Fault” indicator is on or flickers: inverter is powered on but system fault occur. Refer to section 6.3 to check the fault code in LCD display, stop the inverter as per section 5.3, and rule out faults according to chapter 8. After all the faults are removed, repeat the operations in chapter 5.

(6) Set the inverter time according to local time setup; refer to section 6.4.4 to complete time setup.

(7) The default DC input mode of PV grid-connected inverter is “independent” mode; refer to section 6.4.4 to check and set DC input mode.

5.3 Inverter stop

When it is necessary to carry out power-off maintenance, inspection and fault elimination on the inverter, stop the inverter according to the following steps:

- (1) Disconnect the breaker on inverter public grid AC side;
- (2) Disconnect the integrated DC switch of the inverter;
- (3) Disconnect the circuit switch on PV string DC input side;
- (4) Wait for at least 5 minutes until the internal parts of the inverter are fully discharged, and complete the stop operation.

5.4 Daily maintenance and inspection

In solar PV grid-connected power generation system, the 3-phase PV grid-connected inverter can realize grid-connected power generation and stop/start operations automatically day and light in whatever seasons. In order to safeguard and prolong the service life of the inverter, it is necessary to carry out daily maintenance and inspection on the inverter besides using the inverter strictly according to this manual.

5.4.1 Periodic maintenance on the inverter

Item	Inspection mode	Maintenance period
Save the inverter running data	Adopt monitoring software to read the inverter data in real time, and backup the data recorded by monitoring software periodically. Save the inverter running data, parameters and logs into the file, check the monitoring software and various parameter setup of the inverter.	Once per quarter
Inverter running state	Observe whether the inverter is installed firmly, damaged or deformed. Listen for abnormal noise during inverter operation. Check the variables during system grid-connected running. Check whether the temperature of inverter enclosure is normal and monitor the heating condition with thermal imager.	Once per half a year
Clean the inverter	Check the RH and dust around the inverter, and clean the inverter when necessary. Refer to section 5.4.2.	Once per half a year
Electrical connection	Check whether system cable connection and inverter terminal block are loosened, if yes, secure them again in the manner specified in section 4. Check whether the cable is damaged, and whether the cable skin touched by the metal surface is cut.	Once per half a year
Maintenance and replacement of cooling fan	For three-phase inverters, observe whether the air inlet/outlet is normal; check whether there are cracks on the fan leaf. Listen for abnormal noise during fan rotation. Clean the air inlet/outlet if necessary; If any abnormality occurred to the fan, replace the fan immediately . Refer to section 5.4.2.	Once per half a year
Safety function	Check the inverter LCD and stop function of the system. Simulate stop operation and check the stop signal communication. Check the warning marks and replace them if necessary.	Once per half a year

5.4.2 Maintenance guidance

The operation steps of the BG40-70KTR and BG70KTR-HV are as follows:

Clean the inverter

The cleaning steps are listed below:

- (1) Disconnect the connection on input and output side;
- (2) Wait for ten minutes;
- (3) Clean the surface and air inlet/outlet of the inverter with soft brush or vacuum cleaner;
- (4) Repeat the operations in section 5.1;
- (5) Restart the inverter.

Clean the fan

The cleaning steps are listed below:

- (1) Disconnect the connection on input and output side;
- (2) Wait for ten minutes;
- (3) Disassemble the inverter in the same process with the installation procedures in section 4, but in reverse order;
- (4) Remove the screws and covers of cooling bin or fan box as shown below:

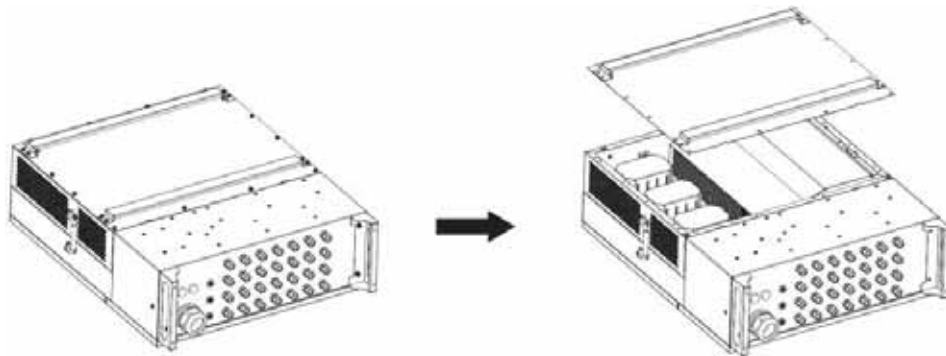

Fig 5.1 Disassemble the cooling bin

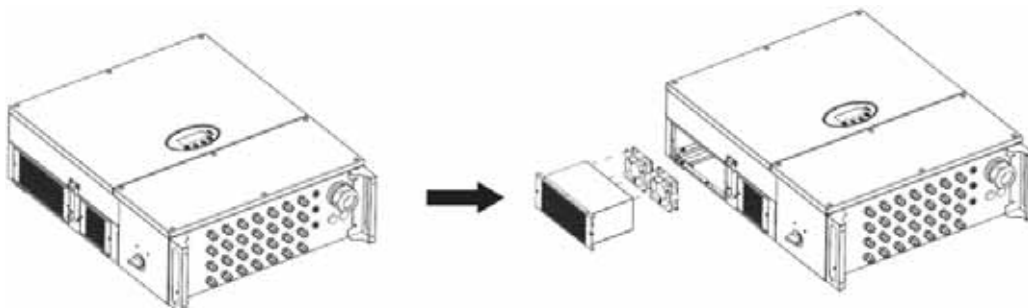



Fig 5.2 Disassemble the fan box

- (5) Clean the inverter cooling bin and fan with soft brush or vacuum cleaner.

- (6) Install the screws and covers of cooling bin or fan box to their original place.
- (7) Install the inverter to its original place again according to section 4.
- (8) Repeat the operations in section 5.1.
- (9) Restart the inverter.

Fan replacement

If high temperature occurred to the inverter or abnormal noise occurred during fan rotating, replace the fan. Note that the fan should be replaced by professionals only.

	<ul style="list-style-type: none"> ● Stop the inverter before maintenance operation, and disconnect all the power inputs of the inverter. ● Before carrying out maintenance operation, wait for at least 10 minutes until the internal capacitors of the inverter are fully discharged, ● The fan can be maintained and replaced by professional electricians only.
---	--

How to replace the fan:

- (1) Disconnect AC breaker;
- (2) Turn the DC switch to “OFF” position;
- (3) Wait for at least 10 minutes;
- (4) Disconnect all the electrical wirings at the bottom of the inverter;
- (5) Lift up the inverter with the help of others and take the inverter off the wall.
- (6) Place the inverter on the operation platform;
- (7) Disassemble the fan box as shown in fig 5.2.
- (8) Disassemble the damaged inverter fan as shown in fig 5.3, then install the fan back to its original position, and connect the fan power and control cable.

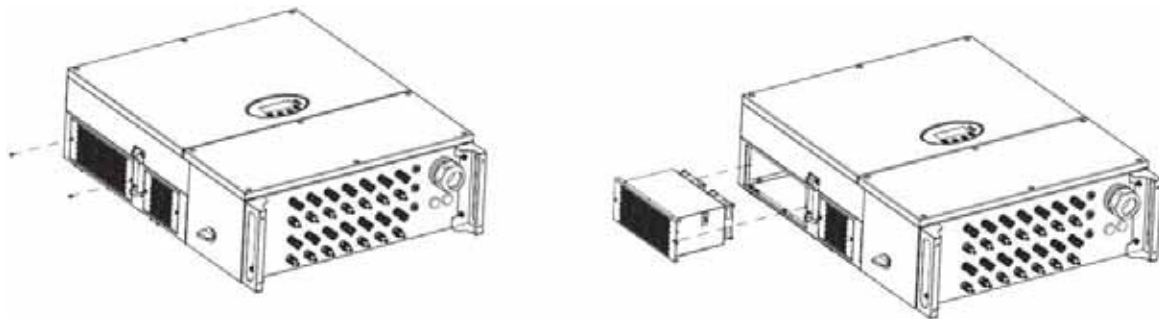

Fig 5.3 Replace the fan

- (9) Install the screws and covers of cooling bin or fan box to their original position.
- (10) Install the inverter to its original position again according to section 4.
- (11) Repeat the operations in section 5.1;

(12) Restart the inverter.

Note	<ul style="list-style-type: none"> Do not start the inverter immediately if it alarms and stops. Figure out the cause according to section 5.1 and confirm all the faults are removed before starting again.
-------------	---

The operation steps of the BG50KTR-HV are as follows:

Inverter cleaning

The cleaning steps are as follows:

- (1) Disconnect the input and output of inverter.
- (2) Wait ten minutes.
- (3) Clean the inverter surface and the air inlet and outlet with a soft brush or vacuum cleaner.
- (4) Repeat the operation contents in section 5.4.
- (5) Restart the inverter.

Fan cleaning

The cleaning steps are as follows:

- (1) Disconnect the input and output of inverter.
- (2) Wait ten minutes.
- (3) Disassemble the inverter in the reverse of the installation procedure in section 3.

Remove the screws and cover of the heat sink or fan case. As shown below:

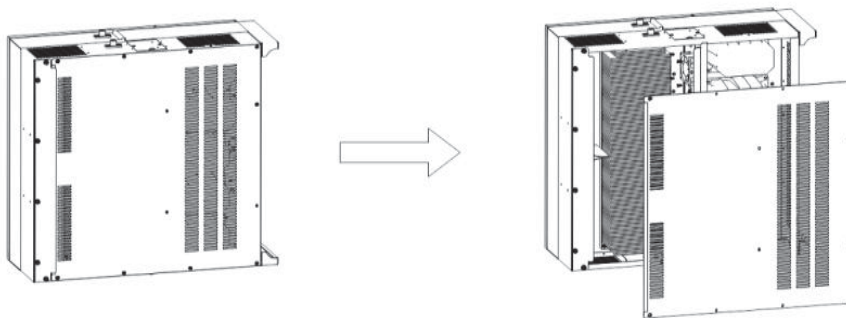

Figure 5.4 Disassembly of the heat sink

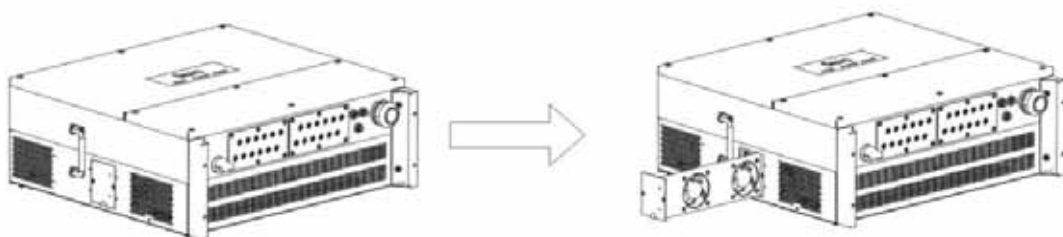



Figure 5.5 Disassembly of fan box

- (1) Clean the inverter heat sink and fan with a soft brush or vacuum cleaner.
- (2) Install the screws and cover of the heat sink or fan case to their original positions.
- (3) Reinstall the inverter to its original position in accordance with section 4.
- (4) Repeat the operation contents of section 5.4.
- (5) Restart the inverter.

Replace the fan

If the inverter has high temperatures or the fan is running abnormally, replace the fan. This operation must be performed by professionals.

	<ul style="list-style-type: none"> ● The inverter must be shut down and all power inputs of the inverter must be disconnected before maintenance work begins. ● Wait at least 10 minutes, the maintenance work can only be carried out after the capacitor inside the inverter has been discharged. ● Only professional electricians can perform fan maintenance and replacement work.
---	---

The fan replacement steps are as follows:

- (1) Disconnect AC circuit breaker.
- (2) Turn the DC switch to the "OFF" position.
- (3) Wait at least 10 minutes.
- (4) Disconnect all electrical connections from the bottom of the inverter.
- (5) Lift the inverter with the help of others and remove the inverter from the wall.
- (6) Place the inverter on the operating platform.
- (7) Disassemble the fan case as shown in Figure 5.4
- (8) As shown in Figure 5.6, remove the damaged inverter fan, install the good fan to the original position, and connect the fan power supply and control cable.

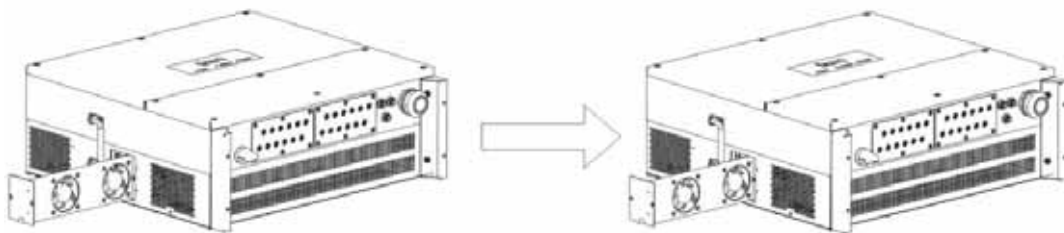

Figure 5.6 Replace the Fan

- (9) Install the screws and cover of the heat sink or fan box to their original positions.
- (10) Reinstall the inverter to its original position in accordance with section 4.

- (11) Repeat the operation in Section 5.4
- (12) Restart the inverter.

Note	<ul style="list-style-type: none">● Once the inverter stops due to an alarm, it is forbidden to start the machine immediately. The cause should be identified and all faults must be eliminated before starting up. Inspections should be carried out in strict accordance with the procedures in Section 5.4.
-------------	--

6 Display operation panel

This chapter mainly presents the usage of inverter display and operation panel, including LED state indicators and operation keypads.

Users can obtain the running state and running parameters of the inverter through LED indicators and the information in LCD display, or change the content displayed in LCD and set the inverter parameters via operation keypad, as shown in fig 6.1.

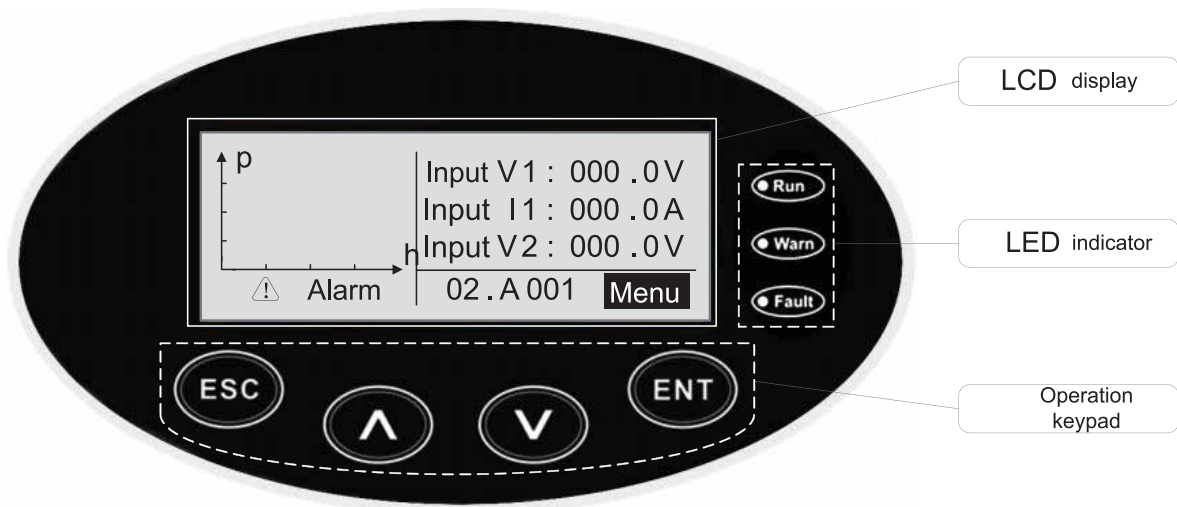

Fig 6.1 Inverter display operation panel

6.1 LED state indicator

There are three LED state indicators in the inverter display operation panel, they are:

- (1) "Run", running state indicator, green light;
- (2) "Warn", restorable fault alarm indicator, yellow light;
- (3) "Fault", non-restorable fault alarm indicator, red light.

The inverter states can be divided into sleep, self-inspection, grid-connected power generation, restorable fault, non-restorable fault and manual turn-off; the LED indicators carry three states: OFF, flicker and ON. Refer to table 5-1 for LED indicator and inverter states.

“○” indicates the LED is OFF;

“◐”(green), “◑”(yellow), “◒”(red) indicate that LED flickers at .25s or 0.58s interval;

“●”(green), “●”(yellow), “●”(red) indicates the LED is ON.

Table 6-1 LED indicator and inverter state

Inverter state	LED indicator	State description
Sleep	<ul style="list-style-type: none"> <input type="radio"/> Run <input type="radio"/> Warn <input type="radio"/> Fault 	Inverter is not power on; all the LED indicators are OFF.
Self-inspection	<ul style="list-style-type: none"> <input checked="" type="radio"/> Run <input type="radio"/> Warn <input type="radio"/> Fault 	Inverter DC input is power on and fulfills self-inspection condition; green light flickers at 0.25s interval and other indicators are OFF.
Grid-connected power generation	<ul style="list-style-type: none"> <input checked="" type="radio"/> Run <input type="radio"/> Warn <input type="radio"/> Fault 	All is normal after inverter self-inspection, and grid-connected power generation is on; green light is ON and other LED indicators are OFF.
	<ul style="list-style-type: none"> <input checked="" type="radio"/> Run <input checked="" type="radio"/> Warn <input type="radio"/> Fault 	<p>(1) Grid-connected power generation is on, but clock is abnormal (A007);</p> <p>(2) Grid-connected power generation is on, but DC input is abnormal (A001 or E001);</p> <p>(3) Grid-connected power generation is on, but fan fault occurred (E006 or E012);</p> <p>Green and yellow lights are ON, other LED indicators are OFF.</p>
Restorable fault state	<ul style="list-style-type: none"> <input type="radio"/> Run <input checked="" type="radio"/> Warn <input type="radio"/> Fault 	<p>Inverter sleep state, public grid abnormal (A001, A003, A004, A005 or A006);</p> <p>Yellow light flickers at 0.5s interval, other LED indicators are OFF.</p>
	<ul style="list-style-type: none"> <input type="radio"/> Run <input checked="" type="radio"/> Warn <input type="radio"/> Fault 	<p>(1) Inverter sleep state, inverter temperature is abnormal (E006);</p> <p>(2) Inverter sleep state, DC input is abnormal (E001);</p> <p>Yellow light is ON, other LED indicators are OFF.</p>
Non-restorable fault state	<ul style="list-style-type: none"> <input type="radio"/> Run <input type="radio"/> Warn <input checked="" type="radio"/> Fault 	<p>Inverter hardware or software fault (E003, E004, E005, E008, E009, E011, E013 or E015), inspection is required, separate the inverter from the system immediately;</p> <p>Red light flickers at 0.5s interval, other LED indicators are OFF.</p>

	<ul style="list-style-type: none"> ○ Run ○ Warn ● Fault 	<p>Electric leakage occurred to the inverter, or the quality of inverter output energy is unqualified (E007, E010, E014, E017, E018 or E020), inspection is required, separate the inverter from the system immediately;</p> <p>Red light is ON, other LED indicators are OFF.</p>
Manual OFF state	<ul style="list-style-type: none"> ● Run ● Warn ● Fault 	<p>Turn off after receiving communication command or keypad command, all the three indicators are ON</p>
Note	Detailed inverter fault information and solutions, refer to chapter 5 and chapter 7.	

6.2 Operation keypad

The operation keypad area of inverter display operation panel has four buttons, they are:

- (1) “ESC”: Exit and return;
- (2) “^”: Page up and value up;
- (3) “v”: Page down and value down;
- (4) “ENT”: Confirm.

6.3 LCD panel

The LCD of inverter display operation panel supports graphics and backlight effect. Under sleep or running state of the inverter, if there is no button action in 15s, LCD backlight will turn off automatically; press any key on the operation manual can light up the LCD backlight again, then press “ENT” key to enter the main menu interface of the inverter LCD (as shown in fig 6.3) where users can view parameters and carry out setups.

The LCD interface is divided into main interface and menu interface, and the former is the default interface at power up. In menu interfaces at all levels, users can check inverter monitoring parameters, historical records, system information, statistic information and current fault information, etc, or set LCD display language, time, inverter communication address, user password, ON/OFF operation, restore to default values, etc.

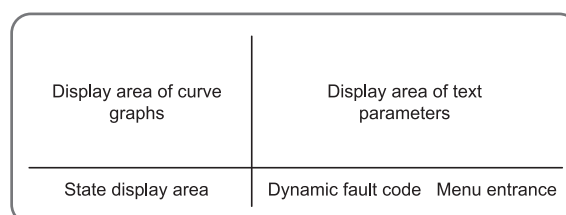

Fig 6.2 Main interface of inverter LCD

The main interface of inverter LCD is shown in fig 6.2:

- (1) The curve graph display area displays the power change curve of current day;
- (2) Text parameter display area displays the key running parameters of current inverter operation, which displays three rows of parameters every time. Under running or sleep state of the inverter, the displayed content rolls up per screen at 3s interval; press “^” or “v” to look through the displayed content;
- (3) State display area displays current running state of the inverter, which can display “self-inspection”, “grid-connected power generation”, “alarm”, “fault”, “OFF” state;
- (4) Dynamic fault code and menu entrance. When the state display area displays “alarm” or “fault”, the dynamic fault code area will display corresponding fault code (display up to 8 fault codes).

6.4 Function operation

Users can view parameters and perform setup operations via the operation keypad and the LCD on the operation panel.

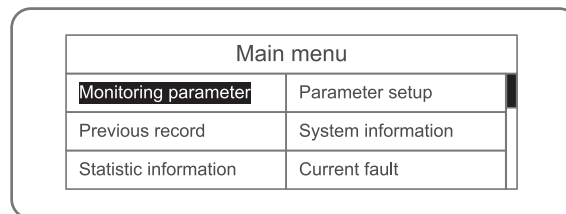

Fig 6.3 Main menu interface of inverter LCD

6.4.1 Monitoring parameter

Press “^” or “v” on the main menu to select “monitoring parameter”, and press “ENT” key can view the monitoring parameters of the inverter, as shown in fig 6.4. Press “^” or “v” to flip the screen, press “ESC” to return.

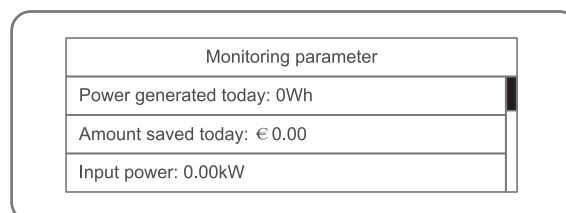

Fig 6.4 Monitoring parameter

The parameters displayed vary with the different models of the inverter, as shown in table 6-2. “●” indicates the “monitoring parameters” can be displayed by corresponding inverter LCD.

Table 6-2 Monitoring parameter

Item	40-70kW / 70kW-HV / 50kW-HV
Power generated today	●
Saved today	●
Input power	●
Output power	●
Peak power	●
Grid voltage (U)	●
Grid voltage V	●
Grid voltage W	●
Grid current (U)	●
Grid current V	●
Grid current W	●
Grid frequency	●
Power factor	●
Input V (V1)	●
Input I (I1)	●
Input V2	●
Input I2	●
Grounding resistance	●
Leakage current	●
Temperature 1	●
Temperature 2	●
Total power	●
Total time	●
Current date	●
Current time	●
Up time of initial power-on	●
Initial working time	●
Time when today's peak power occurred	●
Time when today's power generation ends	●
Time when yesterday's power generation ends	●

6.4.2 Historical records

Press “^” or “v” in the main menu to select “historical record”, then press “ENT” to view the historical records of partial running parameters of the inverter, as shown in fig 6.5.

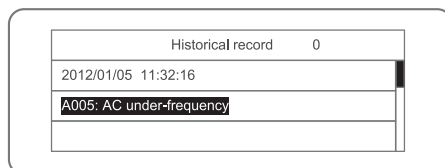

Fig 6.5 Historical record

“Historical record” can display 32 pieces of historical information, press “^” or “v” key to look through the historical information, press “ESC” to return. The number on the upper right corner of the first row is the number of historical record, the 2nd row (as shown in fig 6.5) displays the date and time when fault occurred or restored, and the 3rd row displays detailed information of fault code. When the 3rd row displays in inverse color, it indicates fault occurred, otherwise it is fault restored.

6.4.3 Statistic information

Press “^” or “v” key in the main menu to select “statistic information”, then press “ENT” key to enter “statistic menu”, as shown in fig 6.6.

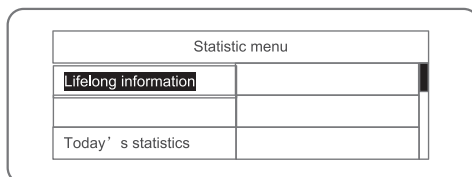

Fig 6.6 Statistic information

The content that can be viewed in “statistic menu” is shown in table 6-3.

Table 6-3 Statistic information of the inverter

Statistic item	Content
Lifelong information	Total running time, total power generation quantity, total amount saved, total CO2 reduced
Today's statistics	Power generated today, peak power, amount saved, CO2 reduced

6.4.4 Parameter setup

Press “^” or “v” in the main menu to select “parameter setup”, then press “ENT” key to enter “setup parameter”, as shown in fig 6.7.

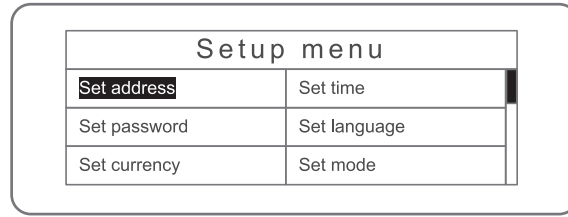

Setup menu	
Set address	Set time
Set password	Set language
Set currency	Set mode

Fig 6.7 Statistic information

“Setup menu” can realize parameter setup shown in table 6-4.

A view of All LCD menus:

	InputV 1 : 0. 0V
	Input I 1 : 0. 0A
	InputV 2 : 0. 0V
	02 . A 001 Menu

Setup menu	
Set address	Set time
Set password	Set language
Set currency	Set country

Main menu	
Monitoring parameter	Parameter setup
Historical record	System information
Statistic information	Current fault

Monitoring parameter	
Power generated today: 0Wh	
Saved today: € Q 00	
Input power: Q 00 kW	

Historical record		0
2012/01/05	11:32:16	
A 005:AC under-frequency		

Statistic menu	
Lifelong information	
Statistic today	

Setup menu	
Set address	Set time
Set password	Set language
Set currency	Set mode

System information	
Product model	Certification area
Product serial no.	Grid-tied parameter
Software ver.	

Fault information	
1 : A005	AC underfrequency
2 : A001	Input undervoltage
3:	

Control menu	
ON/OFF	Restore setup
Clear information	
Reset restart	

Set RS485 address	
00	1

User password	
0000	

Set currency unit price	
Currency: AUD	
Unit price: 0.08 \$A/kWh	

Set date/time	
Date : 2014 / 10 / 27	
Time : 12 : 14 : 30	

Current language : Chinese	
Chinese	Dutch
English	
Germany	

Current country : Austrilia	
Germany	Greece
English	Danmark
Austrilia	Netherlands

Set mode : Independent	
Independent	
Parallel connection	

Set power	
Power limit mode	
Power amplitude	
Power factor	

Individualized setup	
MPPT	start voltage

Grid-connected parameter	
Undervoltage protection	Overvoltage protection
Undervoltage time	Overvoltage time
Overvoltage protection	Under-frequency protection

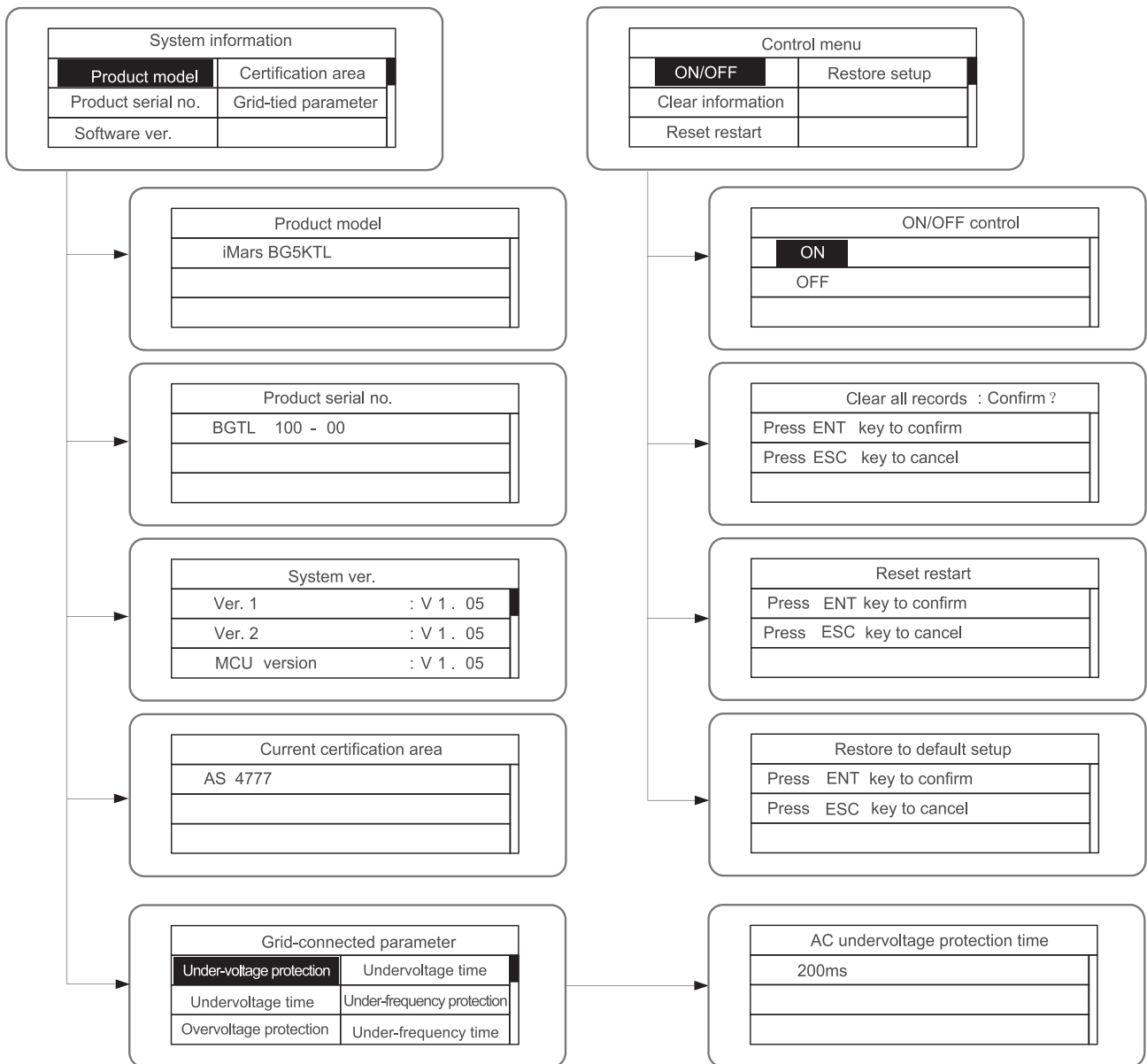
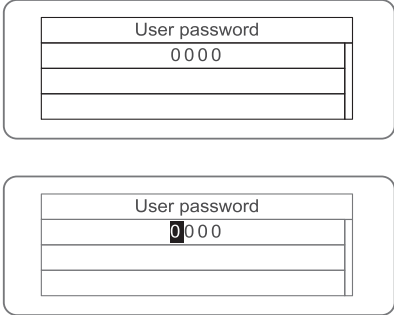
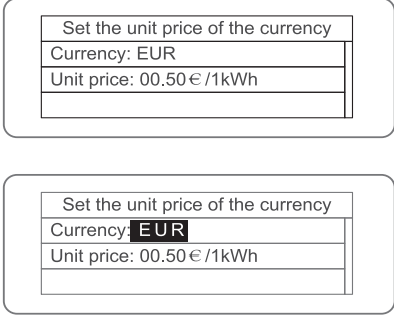
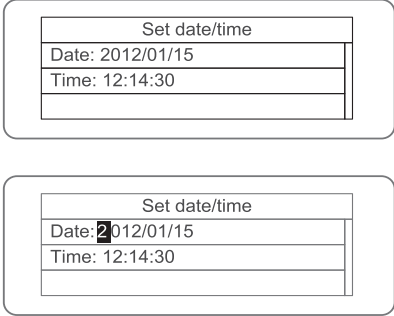

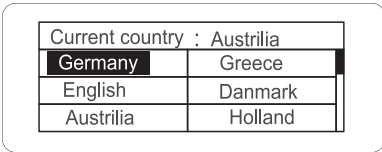
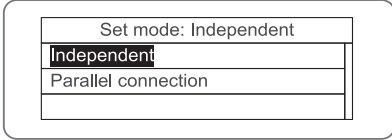

Table 5-4 Inverter parameter setup

Item	LCD display	Instruction
Set address		Press “ENT” key under “set RS485 address” interface, and the cursor will flicker, then press “^” or “v” to edit the data of the bit where cursor resides, after editing, press ENT key and the cursor jumps to next bit. When the cursor is in the 3 rd bit and edition is done, press “ENT” key to complete inverter RS485 address setup. Press “ESC” key to return.

Item	LCD display	Instruction
Set password		<p>Press “ENT” key under “user password” interface, and the cursor will flicker, then press “^” or “v” to edit the data of the bit where cursor resides, after editing, press ENT key and the cursor jumps to next bit. When the cursor is in the 4th bit and edition is done, press “ENT” key to complete user password setup. Press “ESC” key to return.</p> <p>The default password is “0000”, users can enter “setup menu” without password; when user password is not “0000”, it requires password for verification when entering “setup menu”.</p>
Set currency		<p>Press “ENT” key under “set currency unit price” interface to edit the currency and grid-connected electricity price. The currency includes EUR, POD, CNY and USD.</p> <p>When the cursor flickers at “currency” row, press “^” or “v” key can switch the currency; press “ENT” again to jump to “unit price” row and edit the unit price. After editing, press “ENT” to save the setting. Press “ESC” key to return.</p>
Set time		<p>Press “ENT” key under “set date/time” interface to enter edit state, the data of the bit where cursor resides can be edited via “^” or “v” key, after editing, press ENT key to jump to the next bit, then press “ENT” key to save the setup. Press “ESC” to return.</p>

Item	LCD display	Instruction
Set language		<p>Under “current language” interface, press “^” or “v” key to select the language to be displayed, then press “ENT” key to save the setup. Press “ESC” key to return.</p> <p>The default language is English. Enter “menu” in the main interface, then select “setup” in “Main Menu”, select “Language” to set the LCD language.</p>
Set country		<p>Press “^” or “v” key under “current country” interface to select the country to be displayed, then press “ENT” key to save the setup. Press “ESC” key to return.</p>
Set mode		<p>DC input mode is divided into “independent” and “parallel”: “independent” is to carry out independent max power tracking on Track A and Track B PV string; “Parallel mode” is to carry out synchronous max power tracking on Track A and Track B PV string. The default DC input mode of 3-phase PV grid-connected inverter is “independent mode”.</p> <p>The menu option of input mode is invisible under inverter grid-connected running state; power on only at DC, when AC is disconnected, mode selection and setup operation can be performed.</p> <p>Under “setup mode” interface, press “^” or “v” key to select the mode to be set, press “ENT” key to save the setup. Press “ESC” key to return.</p> <p>When the situation described in section 5.4.8 occurred, it is necessary to switch from DC input mode to “parallel” mode.</p>

Item	LCD display	Instruction
Set power		<p>When entering “setup power” interface, password authorization is required, this can be acquired from the supplier. This menu is divided into three sub-menus: ① Power limit mode: invalid mode (namely power limit function is invalid); automatic mode (specific for single-phase machine); manual mode (set the output power amplitude manually); ② Power amplitude: this function is effective only when power limit mode is manual, the percentage ratio is that of the rated power, the setting range is 10%–100%; ③ Power factor: Divided into common mode (default is 1), current lead, and current lag mode, setting range is 0.9–0.99 (3-phase machine currently carries ③ Power factor function only)</p>
Individualized setup		<p>This function is effective on single-phase machine. When entering “individualized setup” interface, password authorization is required, this can be acquired from the supplier. The sub-menu of this menu is “MPPT start voltage” menu, which can set the start voltage of MPPT mode, the setup is 120V–160V</p>

Item	LCD display	Instruction
<p>Set protection point parameter</p>		<p>When entering “individualized setup” interface, password authorization is required, this can be acquired from the supplier . When entering corresponding sub menus, users can set the over/undervoltage, over/under-frequency protection point and the protection time. Press “^” and “v” to change the value, press “ENT” key to confirm.</p>

Item	LCD display	Instruction
<p>Set protection point parameter *</p>		<p>There are two protection points under G83/G59 (Britain), CQC (China) and PEA (Thailand), while for other grid-connected standards, there is only one protection point.</p> <p>Entering corresponding sub menus to set the over/undervoltage, over/under-frequency protection point and the protection time, press “^” and “v” to change the value. Press “ENT” key to confirm.</p> <p>Generally, over/undervoltage protection and under-frequency protection require users to modify the value of undervoltage protection 2 and under-frequency protection 2. Over-frequency protection requires a comprehensive setup of over-frequency protection 1 and over-frequency protection 2.</p>

6.4.5 System information

Press “^” or “v” key to select “system information”, then press “ENT” key to enter “system information” sub-menu, as shown in fig 6.8.

System information	
Product model	Certification area
Product serial no.	Grid-tied parameter
Software ver.	

Fig 6.8 System information

In “statistic menu”, users can check “product model”, “product serial no.”, “software version” and “certification area”. Select “software version” to view “version 1”, “version”, “MCU software version” and RS 485 protocol information of the inverter in “system version”, as shown in fig 6.9.

System version	
Version1	: V1.05
Version 2	: V1.05
MCU software version	: V1.05

Fig 6.9 System version

6.4.6 Present fault

Select “present fault” in the main menu via “^” or “v” key, then press “ENT” key to enter “fault information” sub menu, as shown in fig 6.10.

Fault information	
1:	A005 AC under-frequency
2:	A001 Input under-voltage
3:	

Fig 6.10 Fault information

User can press “^” or “v” key in the “fault information” interface to view the fault records. “Fault information” records the latest 8 pieces of fault information of the inverter, as shown in fig 6.10. When there is no fault currently, it will display “No fault!”. See chapter 6.4.2 for more information on fault records or fault time.

6.4.7 Inverter control

Press “^” or “v” key in the main menu to select “control”, then press “ENT” to enter the sub-menu of “control menu”, as shown in fig 6.11.

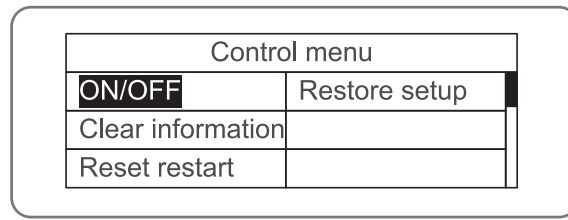
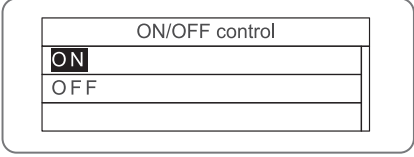
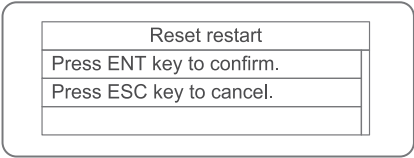
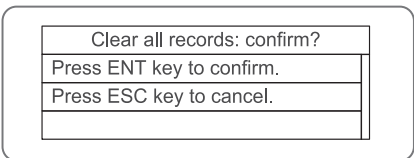
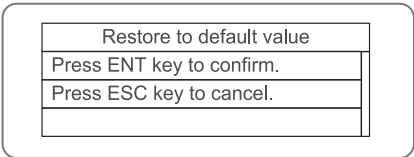

Fig 6.11 Control menu

The “control menu” can control the inverter operation, as shown in table 6-5

Table 6-5 Inverter control

Item	LCD display	Instruction
ON/OFF		<p>Control the ON/OFF of the inverter via keypad.</p> <p>Press “^” or “v” key in “ON/OFF control” interface to select ON or OFF operation, press “ENT” to confirm. Press “ESC” key to cancel and return.</p>
Reset restart		<p>Restart the inverter via keypad, reserve all the setups of the inverter and the historical records of operation.</p> <p>Press “ENT” key in “reset restart” key to restart the inverter and return, the inverter starts self-inspection; press “ESC” key to quit and return.</p>
Clear information		<p>Press “ENT” key in “clear all records” interface to clear all records, press “ESC” key to cancel and return.</p> <p>“Clear information” is to clear all the set parameters of the inverter and restore to default settings, while the historical records of inverter operations will be maintained.</p>
Restore setup		<p>“Restore setup” is to clear all the set parameters of the inverter, and meanwhile, clear all the contents in “historical records”, and restore to the default setting.</p> <p>Press “ENT” key to confirm; press “ESC” key to quit and return.</p>

6.4.8 Mode setup

The default DC input mode of three-phase PV grid-connected inverter is “independent mode”. If fig 6.12 appeared (namely PV string is re-connected to the inverter after passing through combiner box), it is necessary to switch the DC input mode to “parallel” mode.

The inverter with single-channel input has no input mode setup function; the inverter with dual-channel inputs has input mode setup function. See section 6.4.4 for the way to set the input mode.

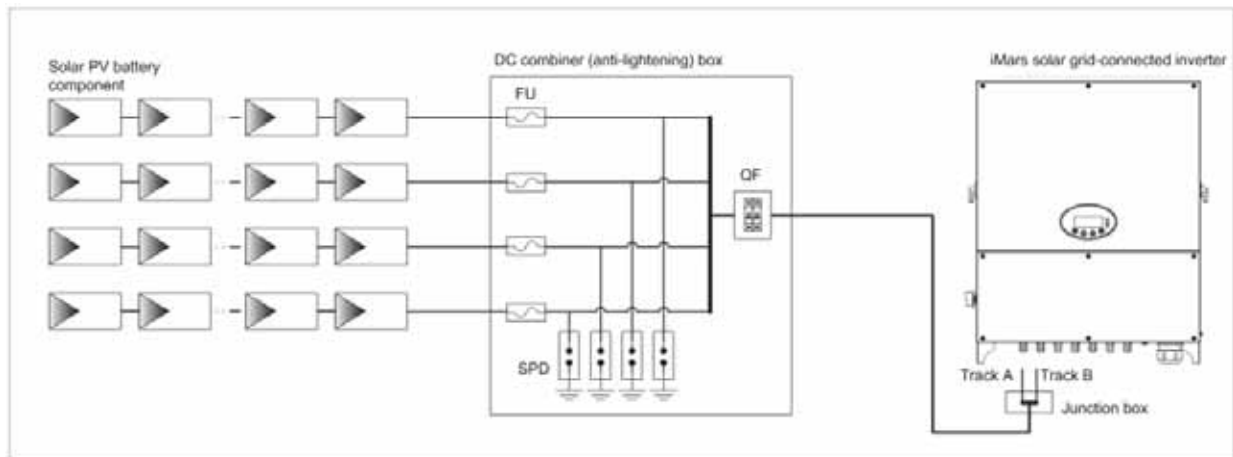
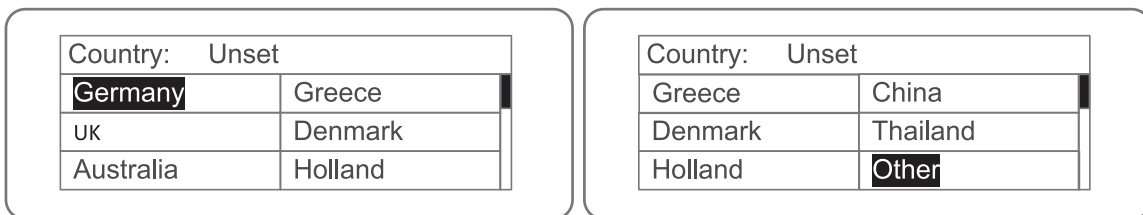

Fig 6.12 “Parallel” input mode

6.5 Selection of grid certification standard

After power up the inverter or restore to default setup for the first time, LCD will display a country list for users to select the country, as shown below:



Press “^” or “v” key to select country (see table below), press ENT key to finish setup. After setting the country, use the inverter according to the requirements in this manual.

Reference table: Countries and grid standards:

No.	Country	Grid standard	Remark
1	Germany	VDE0126& AR-N4105	
2	UK	G83/G59	
3	Australia	AS4777	
4	Greece	VDE0126	

No.	Country	Grid standard	Remark
5	Denmark	TF3.2.1	
6	Holland	C10/C11	
7	China	CQC	
8	Thailand	PEA	
9	Other	VDE0126	

Users can change the country by the following means: LCD: Menu—>Main menu—>Set menu—>Set country

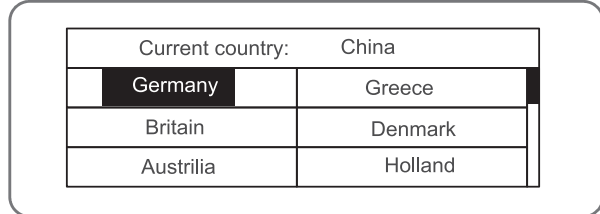
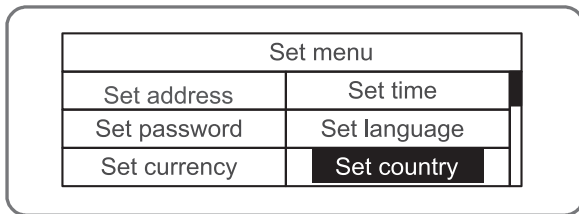
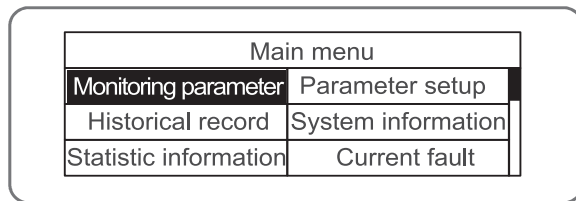
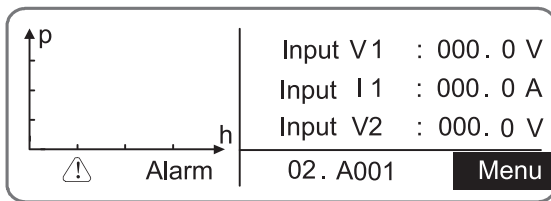

Users can check the grid standard by the following means:

LCD: Menu—>Main menu: System information—>System information: Certification area—>Certification area

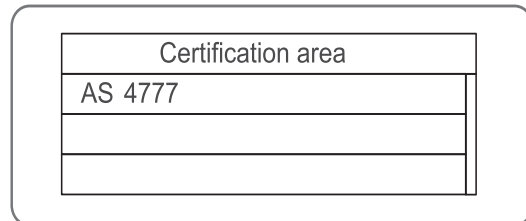
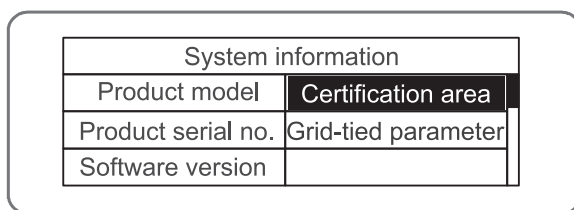

7 Monitoring communication

This chapter mainly introduces the communication connection of inverter and monitoring system (eg industrial control master, PC, smart phone).

7.1 Standard communication

The standard communication mode for three-phase PV grid-connected inverter is RS485, and there are two communication interfaces which are “RS485” and “EXT”. These two communication interfaces can be used in the communication with PC and smart phone to achieve monitoring of the inverter. The monitoring system solution is shown in fig 7.1.

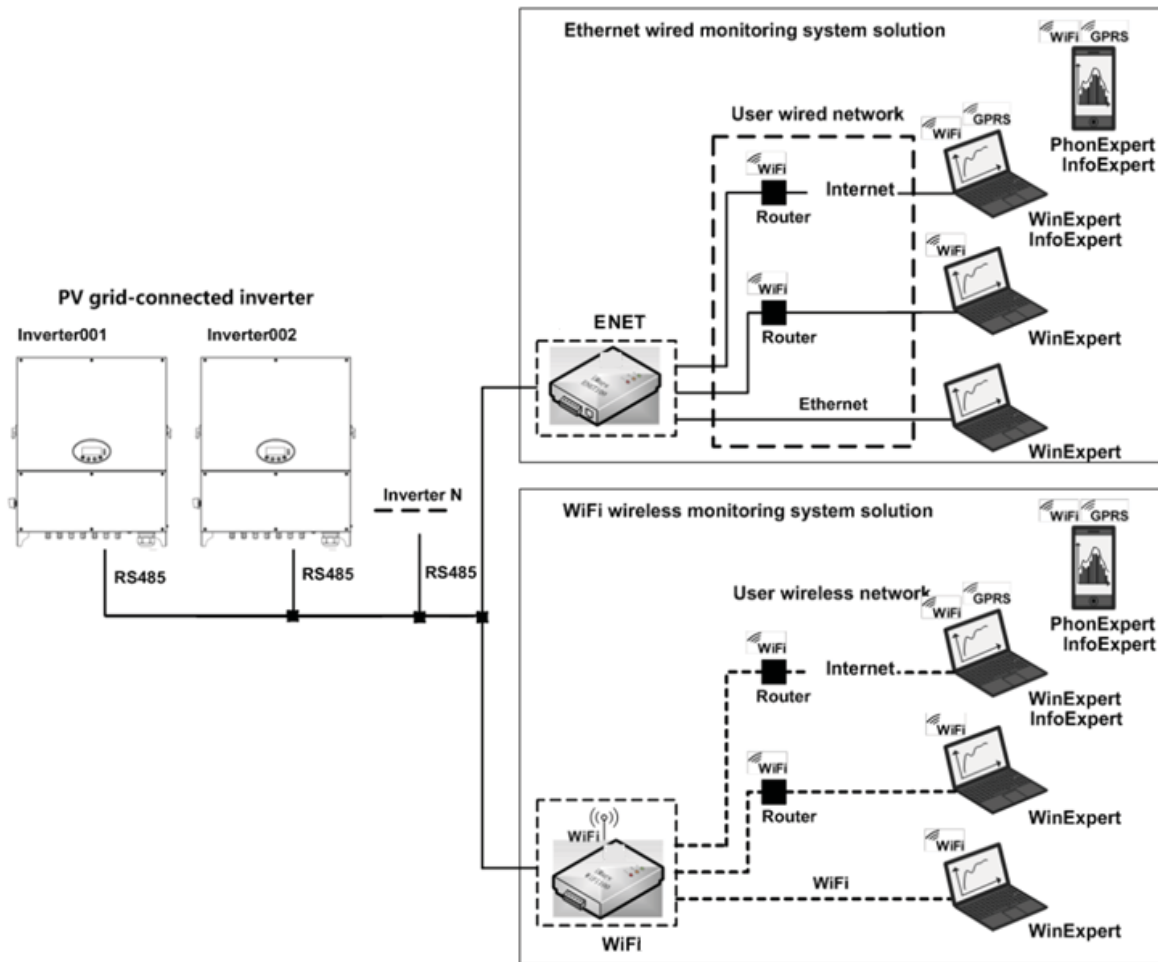

Fig 7.1 Inverter monitoring system

Table 7-1 Instruction for communication connector interfaces

Pin of inverter communication connector	Pin definition
1(Red)	+5VDC
2(Orange)	A(RS485+)
3(Brown)	B(RS485-)
4(Black)	GND

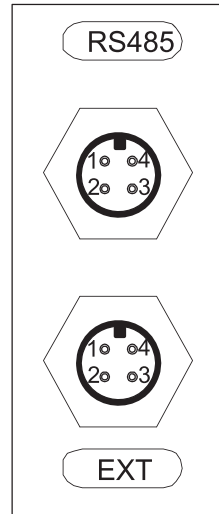

Fig 7.2 Inverter 485 interface diagram Fig 7.3 Standard communication connector

How to connect standard RS485 communication monitoring to the inverter:

- (1) Connect the communication connector configured for the inverter to the RS485 terminal of the inverter, as shown in fig 7.4;
- (2) Connect the outgoing wire of the communication connector to the user device correctly

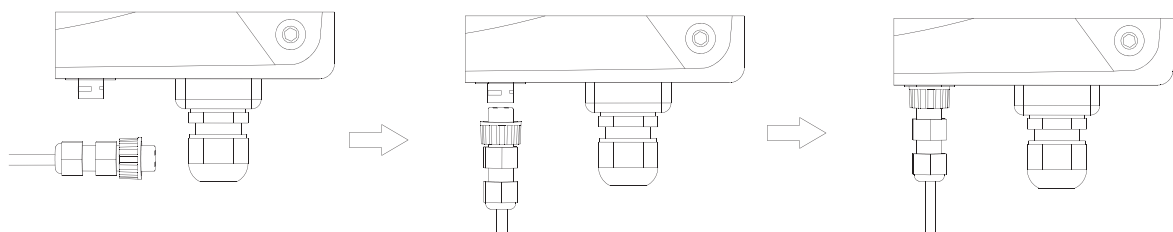

Fig 7.4 Connect communication cable to the inverter

- (3) Please download the monitoring software “iMars WinExpert” and its operation instruction.

7.2 Optional communication

The optional communication modes supported by PV grid-connected inverter are Ethernet, Wifi and GPRS. The optional communication modes must adopt the accessories shown in table 7-2. Output all the running parameters of the inverter to the communication accessories via interface “RS485/EXT”, and finally, connect to the upper computer monitoring system in standard Ethernet, Wifi and GPRS signal, as shown in fig 7.1.

Table 7-2 Communication accessories

Communication accessories	Inverter interface	Upper computer interface
Ethernet converter	RS485/EXT	RJ45 plug
WiFi converter	RS485/EXT	Wireless WiFi signal
GPRS module	RS485/EXT	

Visit www.invt-solar.com to obtain the connection mode of communication accessories and inverter, user manual and the debugging tools.

Note: Communication accessories are not standard configuration and should be purchased separately.

8 Fault isolation

This chapter mainly describes fault alarms and fault codes for figuring out the inverter fault quickly.

Table 8-1 Inverter fault code

Fault code	Prompt in English	Instruction	Fault analysis
A			
A001	Input UV	Input undervoltage	DC input PV1undervoltage DC input PV2undervoltage
A002	Bus UV	Bus undervoltage	DC input
A003	Grid UV	AC undervoltage	Public grid voltage is too low
A004	Grid OV	AC overvoltage	Public grid voltage is too high
A005	Grid UF	AC under-frequency	Public grid frequency is too low
A006	Grid OF	AC over-frequency	Public grid frequency is too high
A007	Clock Fail	Clock error	Inverter clock setup error
A009	Cmd Shut	Manual turn-off	Stop the inverter via manual operation on keypad or upper PC
A011	Grid Loss	Grid loss	Check whether inverter AC wiring is good
E			
E001	Input OV	Input overvoltage	DC input overvoltage
E003	Bus OV	Bus overvoltage	Inverter internal bus overvoltage
E004	Boost Fail	Boost fault	Inverter boost circuit fault
E005	Grid OC	AC overcurrent	Inverter internal AC output overcurrent
E006	OTP	Overheat	Inverter internal temperature is too high
E007	Riso Low	Insulation impedance is too low	The system insulation impedance of inverter external interface is too low
E008	IGBT drv	IGBT drive protection	Inverter IGBT drive protection
E009	IntComm	Internal communication error	Master/slave DSP cannot communicate Master/slave DSP data check error
E010	lLeak Fail	Current leakage is too large	System or inverter current leakage is too large
E011	Relay Fault	Relay fault	Inverter internal relay fault
E012	Fan Fail	Fan fault	Inverter internal fan fault
E013	Eeprom	Memory abnormal	Inverter internal memory fault
E014	Dc inject	The DC component in	The DC component in AC output is too

Fault code	Prompt in English	Instruction	Fault analysis
		AC is too large	large
E015	OutputShort	Output short circuit	AC output short circuit fault
E018	Input OC	Input overcurrent	DC input overcurrent
E019	Incnst	Data consistency fault	Master/slave controller grid voltage, frequency, current leakage or the sampling of AC DC component is inconsistent
E020	PowerReversed	DC power reversal	DC power reversal

If any problem, please contact with the supplier and provide following information:

- Model of the inverter: _____;
- Serial No. of the inverter: _____;
- System version:
——version 1: _____;
- version 2: _____;
- MCU software version: _____;
- Fault code: _____;
- Fault description _____

9 Contact us

China·Shenzhen

INVT Solar Technology (Shenzhen) Co., Ltd.

Address: 7# Building, Gaofa Industrial Park, Longjing, Nanshan district, Shenzhen

Service hotline: +86 400 700 999

E-mail: solar-service@invt.com.cn

INVT group website: www.invt.com

INVT solar website: www.invt-solar.com

10 Appendix

Table 9-1 Technical parameters of three-phase PV grid-connected inverter

Model		Three-phase						
		40kW	50kW	60kW	70kW	70kW-HV	50kW-HV	
DC	Max DC voltage (V)	1100	1100	1100	1100	1100	1100	
	Starting voltage (V)	200	200	200	200	200	200	
	MPPT voltage range (V)	570~1000					620~1000	
	DC input voltage range during rated power (V)	600~850					700~850	
	MPPT number/number of connectable strings per group	1/8	1/10	1/14			2/5	
	Max DC power (W)	55000	66000	72000		78000	6600	
	Max input current (A)× MPPT number	74×1	90×1	120×1			42×2	
	Isc PV	81	99	132			50.4*2	
	Max inverter backfeed current to the array	0A						
	DC switch	Optional						
AC	Max output power (W)	40000	50000	60000	66000	70000	50000	
	Grid voltage, frequency range (V)	310-480Vac,50Hz(47~51.5Hz)				384~552Vac,50Hz z(47~51.5Hz)	484~594Vac,50Hz (47~51.5Hz)	
	Max AC output current (A)	63.5	72.5	96	96	96	53	
	Maximum output fault current	1050A @ 4.76ms						
	Maximum backfeed current to array	Less than 200 A						
	Maximum output overcurrent protection(A)	125.7	143.5	190	190	190	104.9	
	Power factor	-0.8~+0.8 (adjustable)						
	Harmonic wave distortion	< 3% (at rated power)						
System	Cooling mode	Air cooling						
	Max efficiency	98.60%						
	Euro efficiency	98.20%						
	MPPT efficiency	99.90%						
	Protection level	IP65						
	Power consumption at nighttime	< 1W						
	Protective class	I						
	Overvoltage category	AC:III,PV:II						
	inverter topology	Non-isolated						
	Pollution degree	3						
	Ambient temperature	(-25℃~+60℃) , auto derating is required if the ambient temperature exceeds 45℃						
	RH	4~100%.condensation						
	Max altitude (m)	≤2000, derating is required if the altitude exceeds 2000m						
	Display	3.5' LCD display, support backlight display						
	System language	English, Chinese, Germany, Dutch						
Communication mode	RS485 (standard); Ethernet, WiFi (optional)							
DC terminal	BC03A/ BC03B							
Noise dB(A)	≤55							
Installation mode	Wall installation							
Others	Grid standard	DIN VDE 0126-1-1: 2013, VDE-AR-N 4105: 2011, DIN VDE V 0124-100: 2012, IEC 61727 (IEC62116), AS/NZS 4777.2: 2015, NB/T32004-2013, IEC 60068-2-1: 2007, IEC 60068-2-2: 2007, IEC 60068-2-14: 2009, IEC 60068-2-30: 2005, IEC 61683: 1999, C10/11: 2012						
	Safe certificate / EMC category	IEC 62109-1 : 2010, IEC 62109-2 : 2011, EN 61000-6-2: 2005 / EN 61000-6-3:2007/A1:2011						
Protection function	Input overvoltage protection, input overcurrent protection, DC insulation monitoring, DC monitoring, grounding fault current monitoring, grid monitoring, islanding protection, short-circuit protection and overheat protection, etc.							



Sales E-mail: solar@invt.com.cn Service E-mail: solar-service@invt.com.cn Website: www.invt-solar.com

INVT Solar Technology (Shenzhen) Co., Ltd.

No. 7 Building, Gaofa Scientific Industrial Park, Longjing, Nanshan District, Shenzhen, China

201807(V1.0)